



# **Owner's Manual**

## **Original Instructions**

Commercial Air Conditioners

### Cooling and Heating Recovery Mode Exchanger

Models:

NCHS1B(U)

NCHS2B(U)

NCHS4B(U)

NCHS8B(U)

Thank you for choosing this product. Please read this Owner's Manual carefully before operation and retain it for future reference.

If you have lost the Owner's Manual, please contact the local agent or visit [www.gree.com](http://www.gree.com) or send an email to [global@cn.gree.com](mailto:global@cn.gree.com) for the electronic version.

GREE ELECTRIC APPLIANCES, INC. OF ZHUHAI

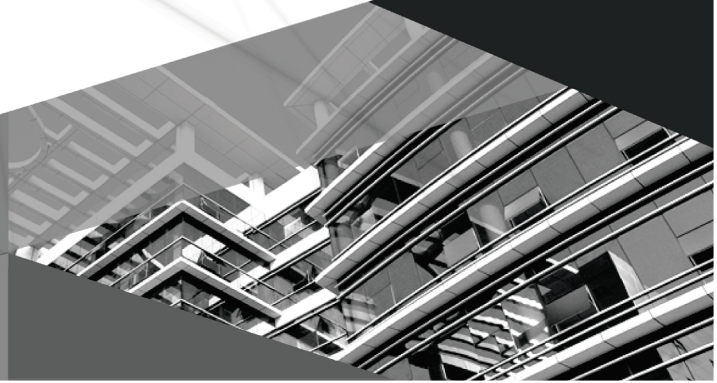

## Preface

For correct installation and operation, please read this manual carefully. Before reading the manual, please note that:

	This is the safety alert symbol. It is used to alert you to potential personal injury hazards. Obey all safety messages that follow this symbol to avoid possible injury or death.
<b>⚠ WARNING</b>	This mark indicates procedures which, if improperly performed, might lead to the death or serious injury of the user.
<b>⚠ CAUTION</b>	This mark indicates procedures which, if improperly performed, might possibly result in personal harm to the user, or damage to property.
<b>NOTICE</b>	NOTICE is used to address practices not related to personal injury.

<b>⚠ WARNING</b>	
(1)	The design standard of multi VRF system conforms to related standard of sales countries.
(2)	To ensure safety when operating this system, please strictly follow the instructions in this manual.
(3)	The total capacity of running indoor units must not exceed that of the outdoor units. Otherwise, the cooling (heating) effect of each IDU would be poor.
(4)	Make sure that this manual is kept by direct operators and maintainers.
(5)	In case of malfunction, please examine the following items and contact our authorized service centers as soon as possible. <ol style="list-style-type: none"> <li>1) Air conditioner's nameplate (model, cooling capacity, product code, ex-factory date)</li> <li>2) Malfunction status (detail description of conditions before and after malfunction occurs)</li> </ol>
(6)	All units have been strictly tested and proved to be qualified before ex-factory. To avoid damage or operation failure which may be caused by improper disassembly, please do not disassemble units by yourself. If disassembly is needed, please contact our authorized service centers.
(7)	All graphics and information in this manual are only for reference. Manufacturer reserves the right for changes in terms of sales or production at any time and without prior notice.
(8)	Under the standby status, the unit will consume a little power for ensuring reliability of the complete unit, maintaining normal communication and preheating refrigerant. When the unit won't be used for a long time, please cut off the power of the complete unit. However, please preheat it when operating the unit next time.

This appliance can be used by children aged from 8 years and above and persons with reduced physical, sensory or mental capabilities or lack of experience and knowledge if they have been given supervision or instruction concerning use of the appliance in a safe way and understand the hazards involved. Children shall not play with the appliance. Cleaning and user maintenance shall not be made by children without supervision.



**DISPOSAL:** Do not dispose this product as unsorted municipal waste. Collection of such waste separately for special treatment is necessary.



# Contents

<b>1 Safety Precautions</b> .....	<b>1</b>
<b>2 Product Introduction</b> .....	<b>2</b>
2.1 Names of Main Parts .....	2
2.2 Parameter table .....	3
<b>3 Preparation before installation</b> .....	<b>3</b>
3.1 Standard Accessory .....	3
3.2 Installation Site .....	4
3.3 Selection Requirement for Communication Wire.....	5
3.4 Wiring Requirement .....	7
<b>4 Installation Instruction</b> .....	<b>7</b>
4.1 Installation of Cooling and Heating Mode Exchanger.....	7
4.2 Pipe Connection .....	13
4.3 Installation and Test for Drainage Hose .....	23
<b>5 Cable Connection</b> .....	<b>25</b>
5.1 Connection of Cable and Terminal of Wiring Board.....	25
5.2 Connect Power Cord .....	26
5.3 Connect Communication Wire of Indoor Unit and Outdoor Unit .....	28
<b>6 Routine Maintenance</b> .....	<b>29</b>
6.1 Notice before Seasonal Use .....	29
6.2 Maintenance after Seasonal Use .....	30
<b>7 Troubleshooting</b> .....	<b>30</b>

# 1 Safety Precautions

<b>⚠WARNING</b>
(1) This product can't be installed at corrosive, inflammable or explosive environment or the place with special requirements, such as kitchen. Otherwise, it will affect the normal operation or shorten the service life of the unit, or even cause fire hazard or serious injury. As for above special places, please adopt special air conditioner with anti-corrosive or anti-explosion function.
(2) Follow this instruction to complete the installation work. Please carefully read this manual before unit startup and service.
(3) Wire size of power cord should be large enough. The damaged power cord and connection wire should be replaced by exclusive cable.
(4) After connecting the power cord, please fix the electric box cover properly in order to avoid accident.
(5) Never fail to comply with the nitrogen charge requirements. Charge nitrogen when welding pipes.
(6) Never short-circuit or cancel the pressure switch to prevent unit damage.
(7) Please firstly connect the wired controller before energize, otherwise wired controller cannot be used.
(8) Before using the unit, please check if the piping and wiring are correct to avoid water leakage, refrigerant leakage, electric shock, or fire etc.
(9) Do not insert fingers or objects into air outlet/inlet grille.
(10) Open the door and window and keep good ventilation in the room to avoid oxygen deficit when the gas/oil supplied heating equipment is used.
(11) Never start up or shut off the air conditioner by means of directly plug or unplug the power cord.
(12) Turn off the unit after it runs at least five minutes; otherwise it will influence oil return of the compressor.
(13) Do not allow children operate this unit.
(14) Do not operate this unit with wet hands.
(15) Turn off the unit or cut off the power supply before cleaning the unit, otherwise electric shock or injury may happen.
(16) Never spray or flush water towards unit, otherwise malfunction or electric shock may happen.
(17) Do not expose the unit to the moist or corrosive circumstances.
(18) Under cooling mode, please don't set the room temperature too low and keep the temperature difference between indoor and outdoor unit within 5° C(41° F).
(19) User is not allowed to repair the unit. Fault service may cause electric shock or fire accidents. Please contact Gree appointed service center for help.
(20) Before installation, please check if the power supply is in accordance with the requirements specified on the nameplate. And also take care of the power safety.
(21) Installation should be conducted by dealer or qualified personnel. Please do not attempt to install the unit by yourself. Improper handling may result in water leakage, electric shock or fire disaster etc.
(22) Be sure to use the exclusive accessory and part to prevent the water leakage, electric shock and fire accidents.
(23) Make sure the unit can be earthed properly and soundly after plugging into the socket so as to avoid electric shock. Please do not connect the ground wire to gas pipe, water pipe, lightning rod or telephone line.
(24) Electrify the unit 8 hours before operation. Please switch on for 8 hours before operation. Do not cut off the power when 24 hours short-time halting (to protect the compressor).
(25) If refrigerant leakage happens during installation, please ventilate immediately. Poisonous gas will emerge if the refrigerant gas meets fire.
(26) Volatile liquid, such as diluent or gas will damage the unit appearance. Only use soft cloth with a little neutral detergent to clean the outer casing of unit.
(27) If anything abnormal happens (such as burning smell), please power off the unit and cut off the main power supply, and then immediately contact Gree appointed service center. If abnormality keeps going, the unit might be damaged and lead to electric shock or fire.

Gree Electric Appliances, Inc. of Zhuhai will not assume responsibility for any personal injury or property loss caused by improper installation, improper test running, and unnecessary repair or not following the instructions of this manual.

## 2 Product Introduction

### 2.1 Names of Main Parts

#### One-to-one Cooling and Heating Mode Exchanger

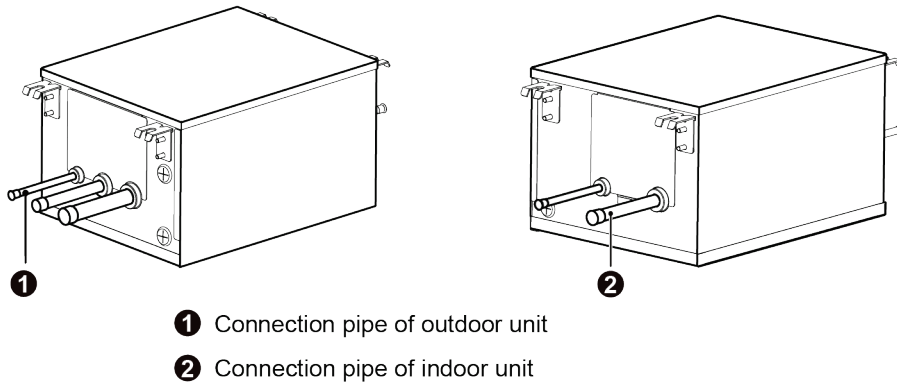

Fig.2.1.1

#### One-to-two Cooling and Heating Mode Exchanger

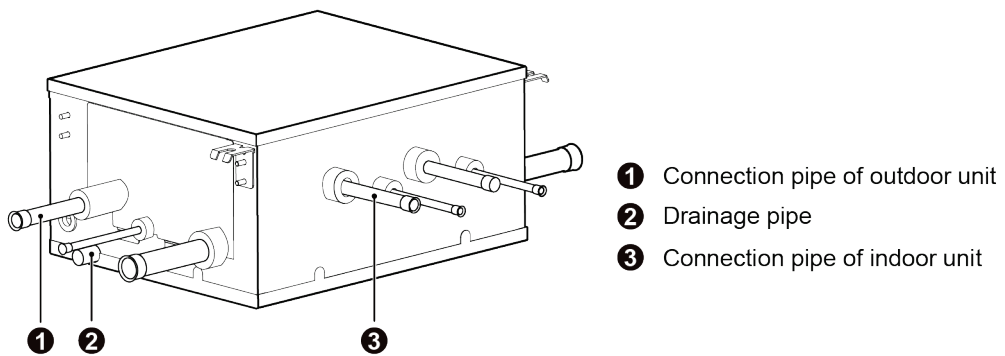

Fig.2.1.2

#### One-to-more Cooling and Heating Mode Exchanger

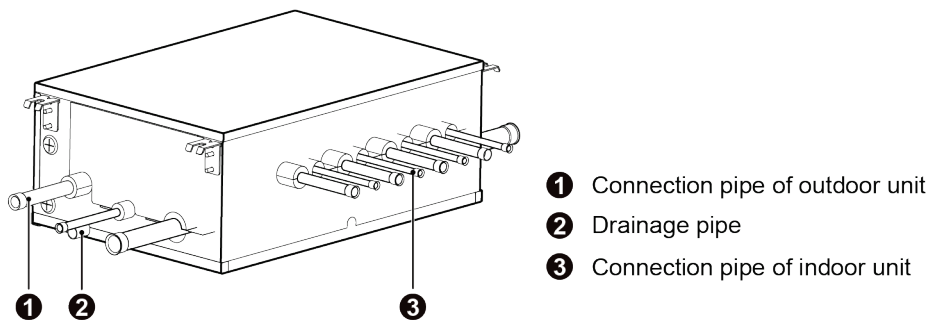

Fig.2.1.3

## 2.2 Parameter table

Model	Unit	NCHS1B(U)	NCHS2B(U)	NCHS4B(U)	NCHS8B(U)
Rated voltage	V	208/230V	208/230V	208/230V	208/230V
Max. quantity of connecting indoor unit	—	8	16	32	64
Max. branch quantity of connecting indoor unit	—	1	2	4	8
Max. quantity of connecting indoor unit for each branch	—	8	8	8	8
Max. total capacity of connecting indoor unit for each branch	Btu/h	48500	48500	48500	48500
Total capacity of connecting indoor unit for mode convertor	Btu/h	48500	96000	154000	232000
Size of high pressure pipe (mode convertor connects outdoor unit)	mm(inch)	15.9(5/8)	19.05(3/4)	22.2(7/8)	22.2(7/8)
Size of low pressure gas pipe (mode convertor connects outdoor unit)	mm(inch)	22.2(7/8)	22.2(7/8)	28.6(1-1/8)	28.6(1-1/8)
Size of liquid pipe (mode convertor connects outdoor unit)	mm(inch)	9.52(3/8)	9.52(3/8)	12.7(1/2)	15.9(5/8)
Size of gas pipe (mode convertor connects indoor unit)	mm(inch)	15.9(5/8)	15.9(5/8)	15.9(5/8)	15.9(5/8)
Size of liquid pipe (mode convertor connects indoor unit)	mm(inch)	9.52(3/8)	9.52(3/8)	9.52(3/8)	9.52(3/8)







## 3 Preparation before installation



### NOTICE!

The product photos are only for reference. The unit for size is mm(inch), except otherwise stated.

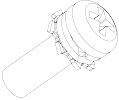
### 3.1 Standard Accessory

Please use below provided standard parts according to requirement.

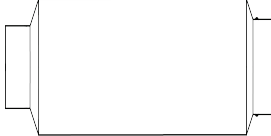
No.	Name	Photo	Quantity	Purpose
1	M10×8 Nut with washer M10×8		4	Used for hanging mode exchanger
2	Nut M10 (hexagon nut M10×8.4)		4	Used for hanging mode exchanger
3	Washer 10 (spring washer M10×2.6)		4	Used for hanging mode exchanger
4	High-temperature tieline		8	Wrap sponges at the connection position
5	Installation template	/	1	Used for drilling holes at the ceiling
6	M4×12 (green bonding screw M4×12)		1	Used for connecting the earthing cord
7	silencer 1		1	The sizes of both nozzles are IDΦ19.3mm(3/4inch) and ODΦ19mm(3/4inch), nozzle ODΦ19mm(3/4inch) is used for connecting the high pressure gas pipe of NCHS2B(U).

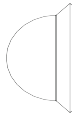
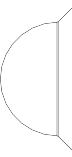
No.	Name	Photo	Quantity	Purpose
8	silencer 2		1	The sizes of both nozzles are ID $\Phi$ 22.3mm(7/8inch) and OD $\Phi$ 28mm(1-1/8inch), nozzle OD $\Phi$ 28mm(1-1/8inch) is used for connecting the high pressure gas pipe of NCHS2B(U).
9	silencer 1		1	The sizes of both nozzles are ID $\Phi$ 22.3mm(7/8inch) and $\Phi$ 22mm(7/8inch), nozzle $\Phi$ 22mm(7/8inch) is used for connecting the high pressure gas pipe of NCHS4B(U) and NCHS8B(U).
10	silencer 2		1	The sizes of both nozzles are ID $\Phi$ 28.3mm(1-1/8inch) and $\Phi$ 28mm(1-1/8inch), nozzle $\Phi$ 28mm(1-1/8inch) is used for connecting the low pressure gas pipe of NCHS4B(U) and NCHS8B(U).
11	sealing cap 1		1	Used for blocking the liquid pipe nozzle
12	sealing cap 2		1	Used for blocking the high pressure gas pipe nozzle of NCHS2B(U), or used for blocking the low pressure gas pipe nozzle of NCHS4B(U) and NCHS8B(U).

The packed attachments should be subject to actual objects. If there are any alterations, there will be no further notice.

### 3.2 Installation Site

- (1) Make sure the hanging parts can hold the weight of unit.
- (2) Water can be drained out from the drainage hose conveniently.
- (3) No obstacles at outlet and inlets. Keep the air ventilation in good condition.
- (4) Connect either left or right side of converter to outdoor unit for piping according to installation space, as shown in the Fig.3.1, the space used for maintenance should be ensured.
- (5) Please keep the unit away from those positions where there's thermal source, inflammable gas and smog.
- (6) The unit is the cassette type (concealed type).
- (7) Indoor unit, outdoor unit, mode exchanger power cord and connection cord should be kept 1m (39-3/8inch) above away from TV and radio for preventing graphic interference and noise. (Even the distance is 1m (39-3/8inch), if there's strong electric wave, there's still noise).

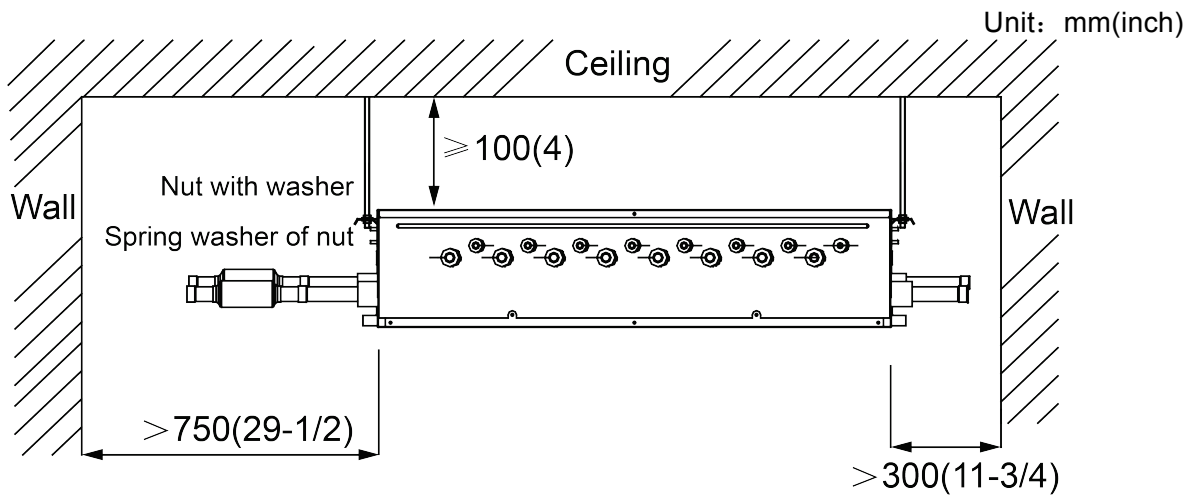

Fig.3.1

<b>NOTICE</b>
① The installation of the unit must comply with national and local safety regulations.
② Users can't install the unit by themselves, because the installation quality will affect the operation directionally. After purchasing the unit, please contact with dealer. The unit must be installed and debugged by professional installer.
③ The unit can be put through power only after all installation work is finished.

### 3.3 Selection Requirement for Communication Wire

**NOTICE!** If the unit is installed at the place where there's strong electromagnetic interference, the communication wire between indoor unit and wired controller must adopt shield wire, and the communication wire between indoor unit and indoor unit (outdoor unit) must adopt twisted wire with shielding function.

Communication Wire between mode exchanger and indoor unit, outdoor unit:



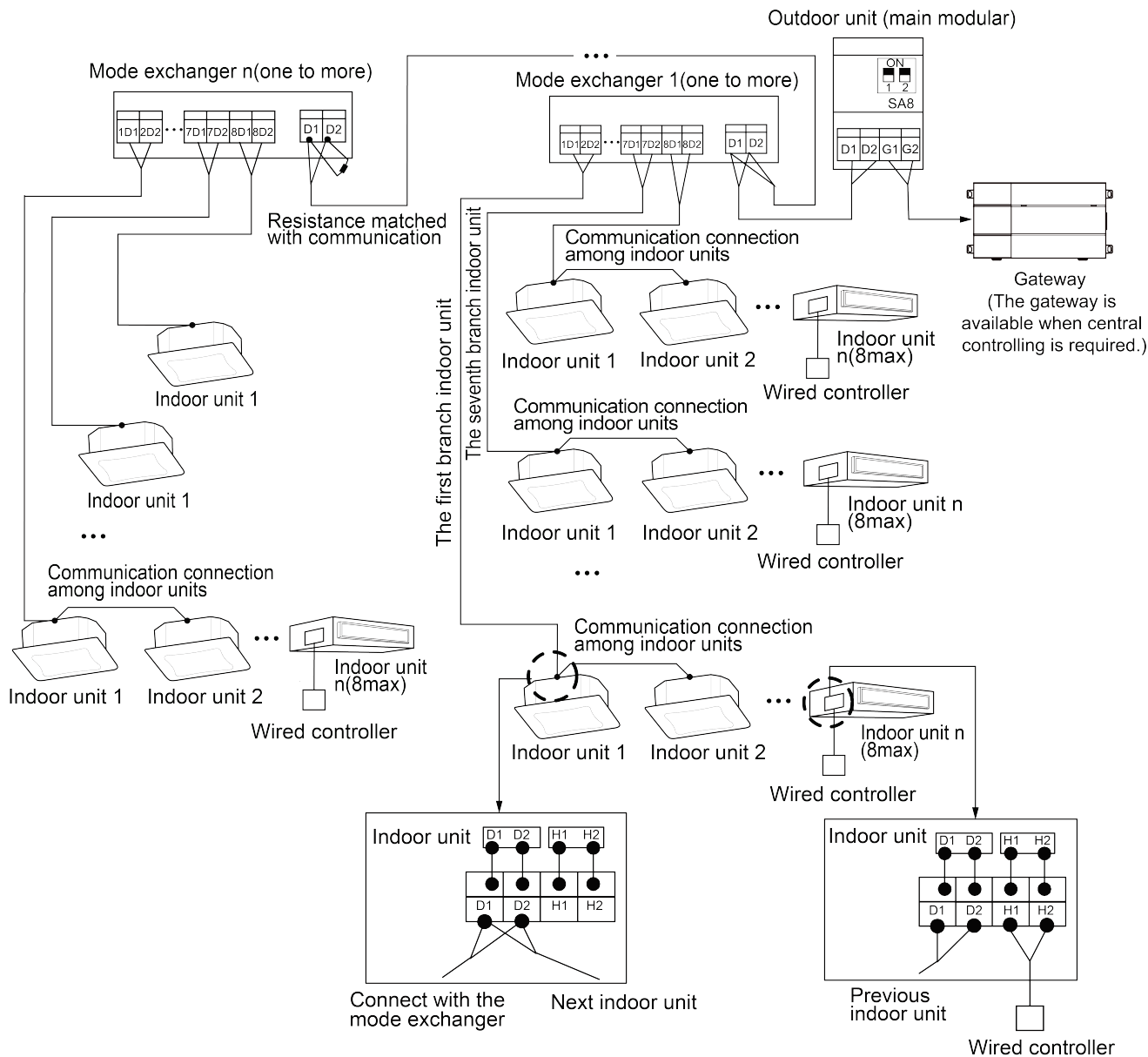

Fig.3.2

Type of wire	Total length of communication wire between mode exchanger and another indoor/outdoor unit L/m(ft.)	Wire size	Remarks
Light/Ordinary polyvinyl chloride sheathed cord	L≤1000(3280-5/6)	AWG16~AWG18	① If the wire diameter is enlarged to 2 ×AWG16, the total communication length can reach 1500m (4921-1/4ft.). ② The cord shall be Circular cord (the cores shall be twisted together). ③ If unit is installed in places with intense magnetic field or strong interference, it is necessary to use shielded wire.

### 3.4 Wiring Requirement

Model	Power	Fuse Capacity(A)	Minimum Circuit Ampacity(A)	Maximum Overcurrent Protection(A)
NCHS1B(U)	208/230V 1Ph 60Hz	15	10	15
NCHS2B(U)	208/230V 1Ph 60Hz	15	10	15
NCHS4B(U)	208/230V 1Ph 60Hz	15	10	15
NCHS8B(U)	208/230V 1Ph 60Hz	15	10	15

<b>NOTICE</b>
Above circuit breaker and power cord speciation are selected according to the max power (max correct).
Specification of power cord is based on the working condition where ambient temperature is 40°C(104°F) and multi-core copper cable (working temperature is 90°C (194°F) , e.g. power cable with YJV cross-linked copper, insulated PE and PVC sheath) is lying on the surface of slot. If working condition changes, please adjust the specification according to national standard.
Specification of circuit breaker is based on the working condition where ambient temperature of circuit breaker is 40°C(104°F). If working condition changes, please adjust the specification according to national standard.
When installation the cut-off device next to the unit, the min space between every two levels of cut-off device should be 3mm (1/8inch) (for indoor unit and outdoor unit).

## 4 Installation Instruction

### 4.1 Installation of Cooling and Heating Mode Exchanger

#### 4.1.1 Dimension of Outdoor Unit and Mounting Hole Position

After the unit is installed, a maintenance port should be reserved at the electric box side of unit for maintenance. The position of maintenance port should be lower than the lower size of unit.

The mode exchanger shall be installed near the maintenance port or air return of indoor unit. (Note: if it is installed near the air return, please make sure not to affect air return and maintenance).

The following pictures detailed describe the installation of maintenance port and mode exchanger:

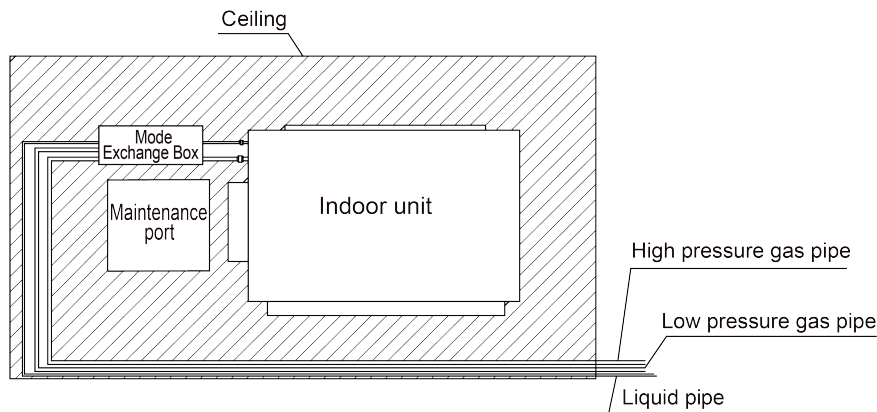

Fig.4.1

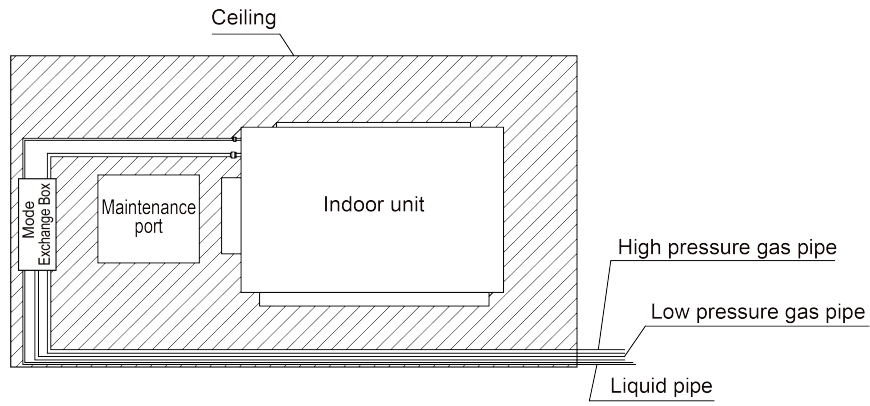

Fig.4.2

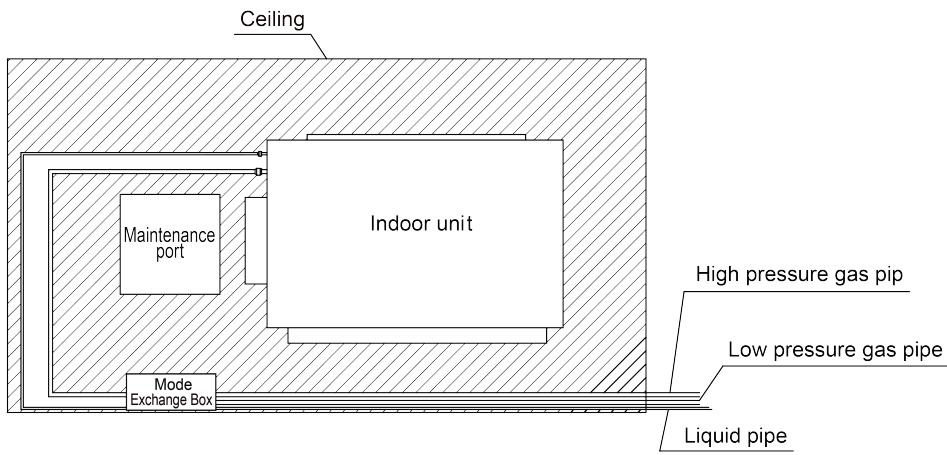

Fig.4.3

Due to the structure of installation space, the mode exchanger needs a maintenance port. Please reserve another maintenance port for mode exchanger.

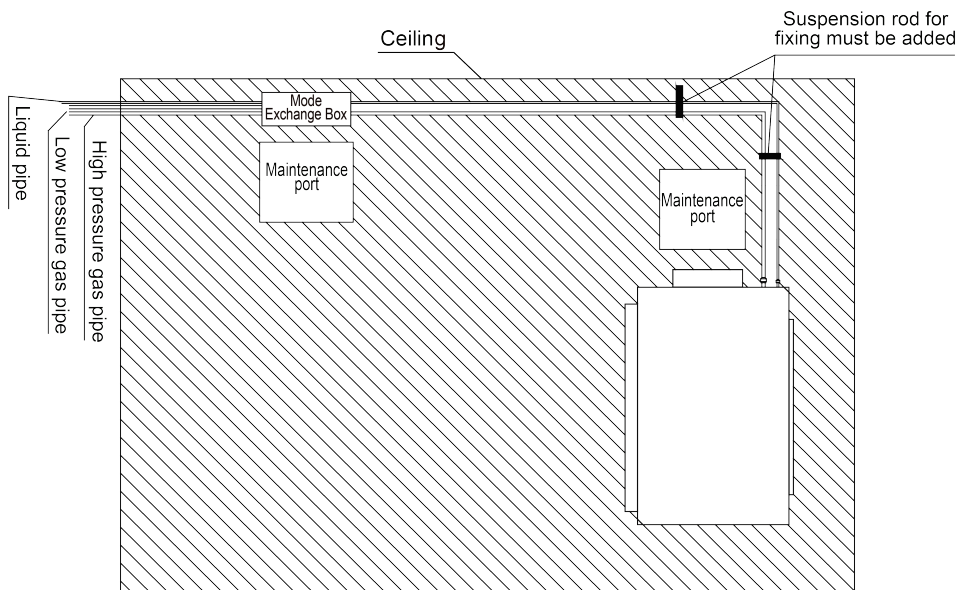

Fig.4.4

NCHS1B(U) outline and installation dimension

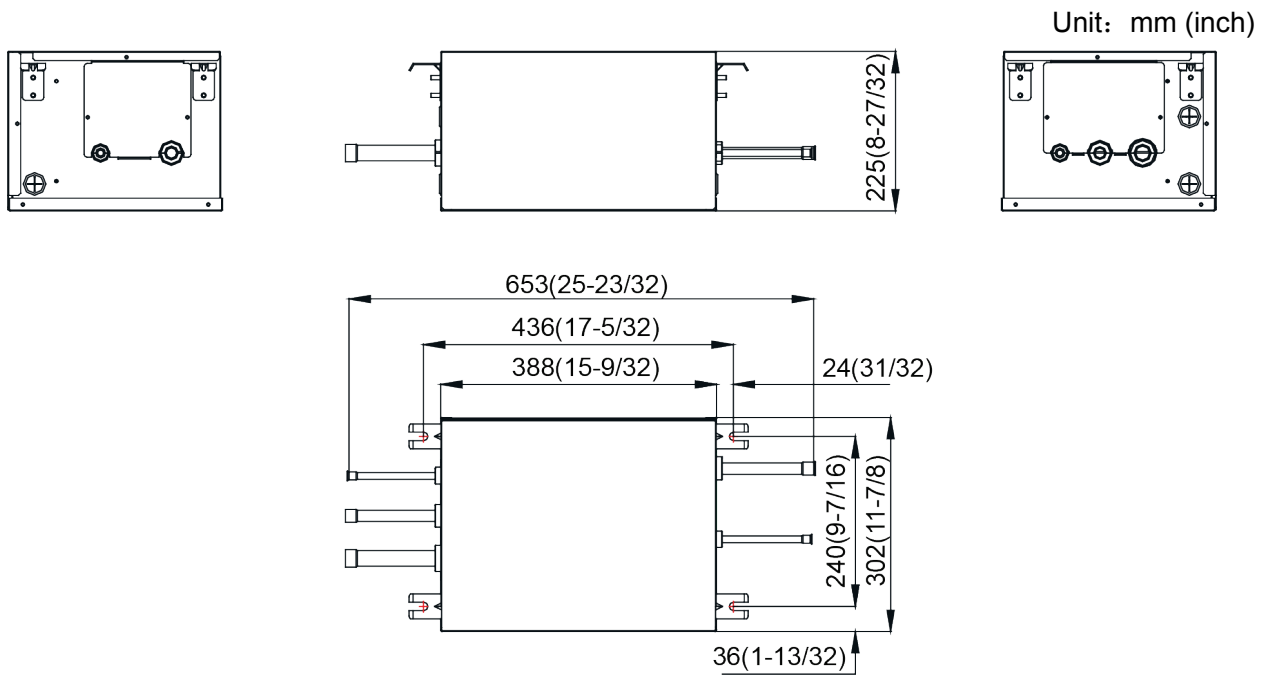

Fig.4.5

NCHS2B(U) outline and installation dimension

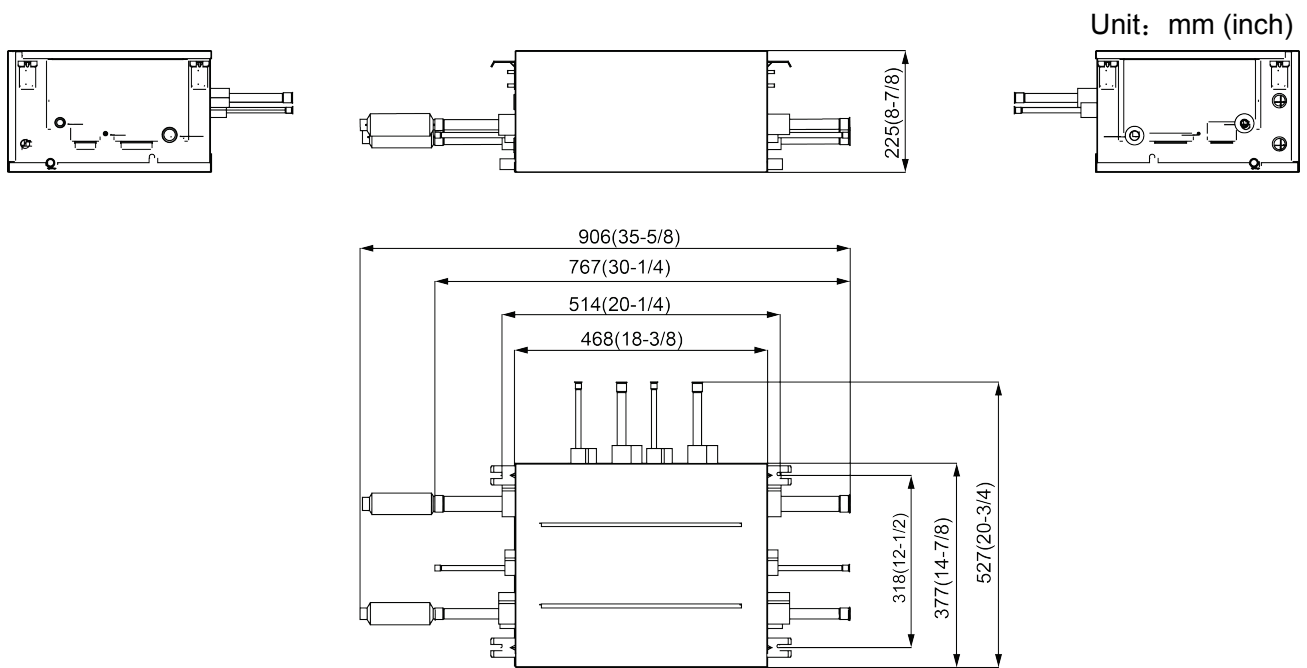

Fig.4.6

NCHS4B(U) outline and installation dimension

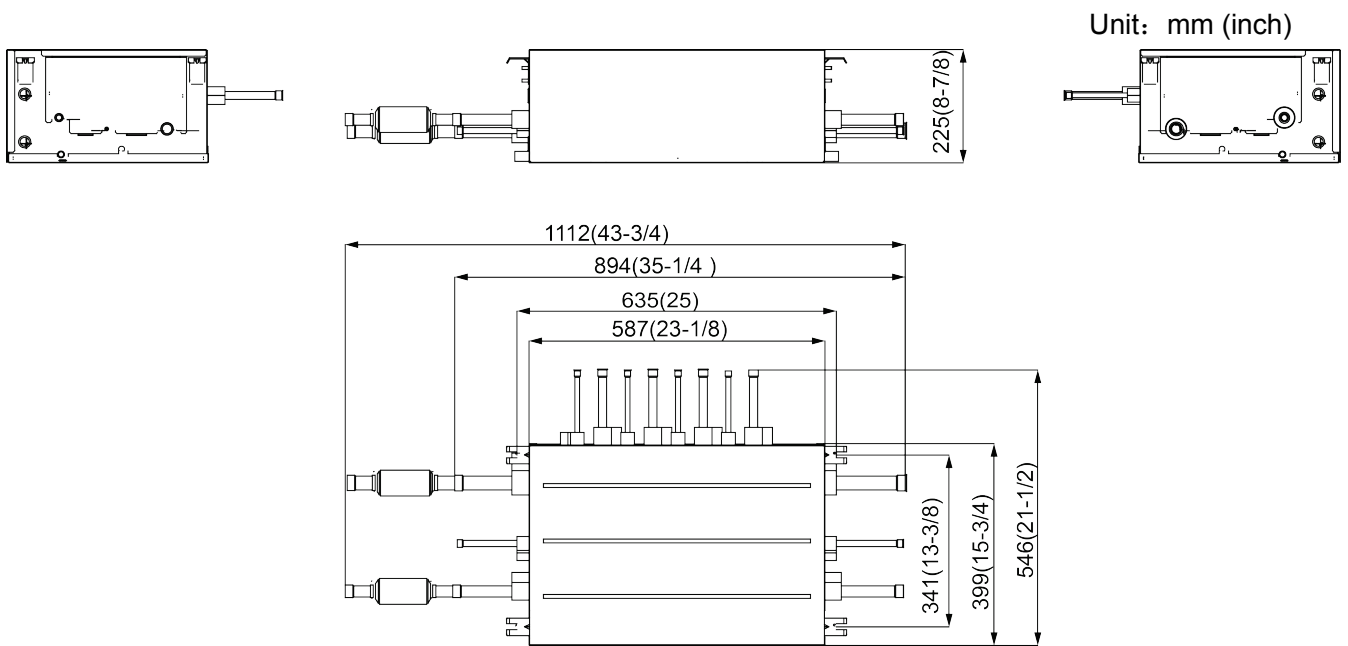

Fig.4.7

NCHS8B(U) outline and installation dimension

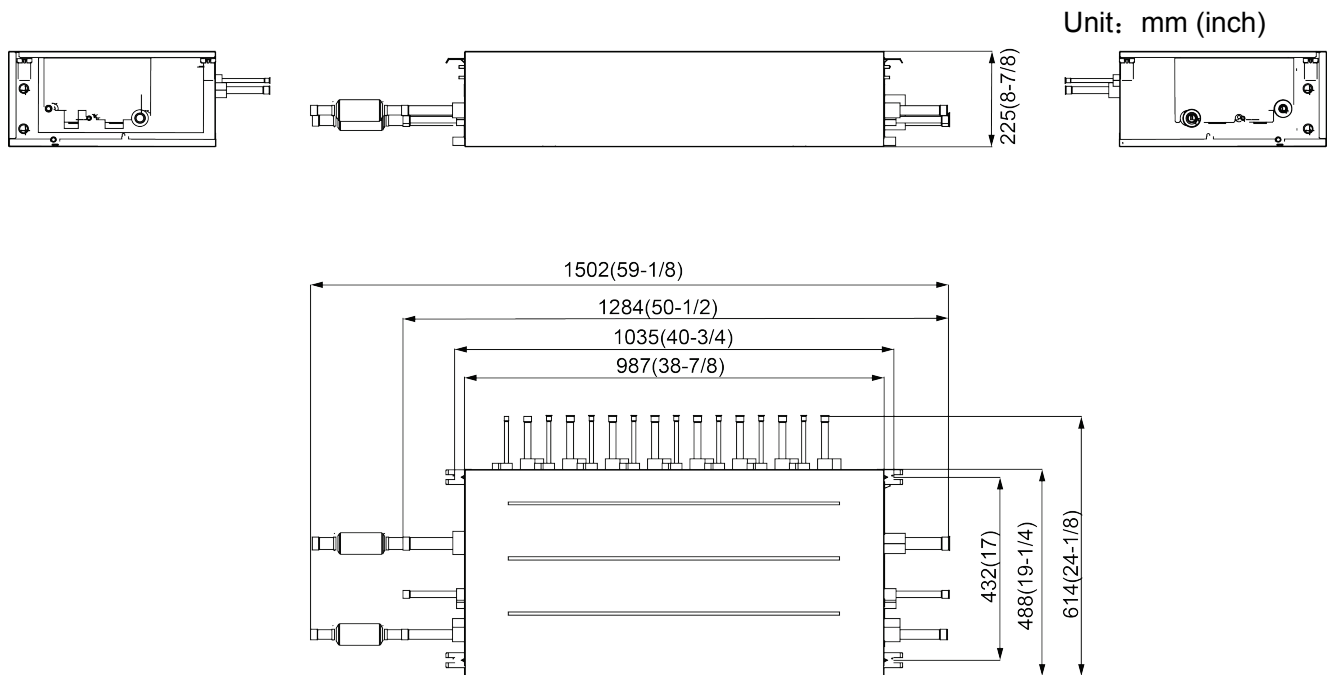

Fig.4.8

4.1.2 Suspend the mode exchanger

(1) Drill bolt holes and install bolts

- 1) Stick the installation template at the installation position flatly, drill 4 holes at the installation position basing on the installation template. As shown in Fig.4.9. Please refer to the diameter of expansion bolt for the diameter of hole with depth of 60-70mm (2-3/8~2-3/4inch). As shown in Fig.4.10.

Unit: mm(inch)

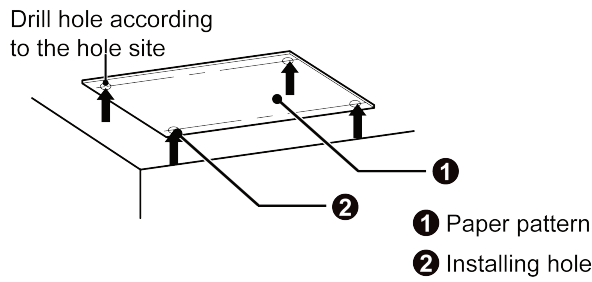

Fig.4.9

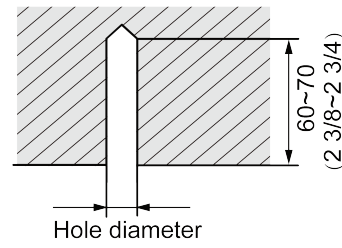

Fig.4.10

- 2) Insert M10 expansion bolt into hole, and then set the iron nail into bolt. As shown in Fig.4.11, and then remove the paper pattern.

**NOTICE!** The length of bolt should be selection according to the height of room. Bolt should be purchased by the user.

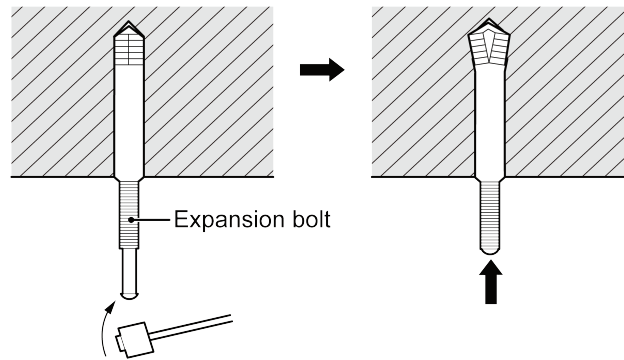

Fig.4.11

- (2) Install the mode exchanger temporarily

Assemble suspension bolt on the expansion bolt, attach the hanger bracket to the suspension bolt. Be sure to fix it securely by using a nut and washer from upper and lower sides of the hanger bracket. The washer fixing plate will prevent the washer from falling.

Unit: mm(inch)

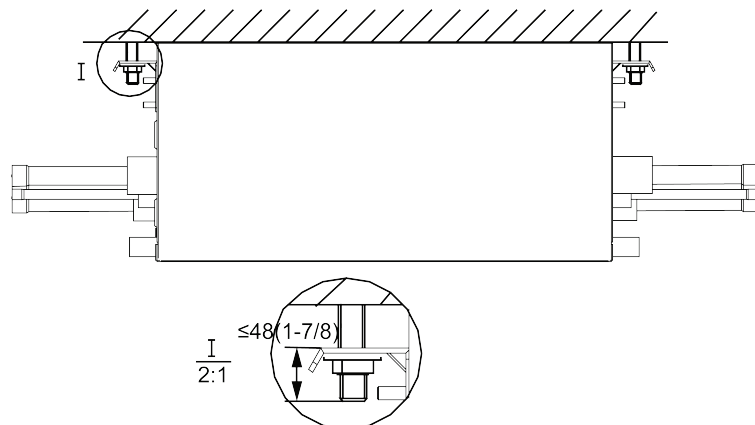

Fig.4.12

**NOTICE**

- ① Before operation, please prepare all pipelines (connection pipe, drainage hose) and wires (connection wire for wired controller, connection wire for mode exchanger).
- ② When drilling holes on ceiling (air return outlet or air outlet), you can need to reinforce the ceiling to prevent vibration. For details, please consult user or builder.
- ③ If the strength of the ceiling is not good, please install a beam bracket, and then put the unit on the beam bracket.

- (3) Adjust the unit to the right position
- (4) Check the level of the unit

After the mode exchanger is installed, remember to check the horizontal status of the whole unit. It should be horizontal from front to back and slant 1% from left to right, following the drainage direction.

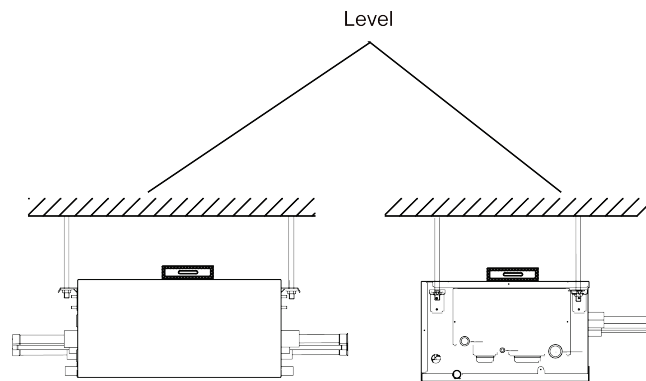
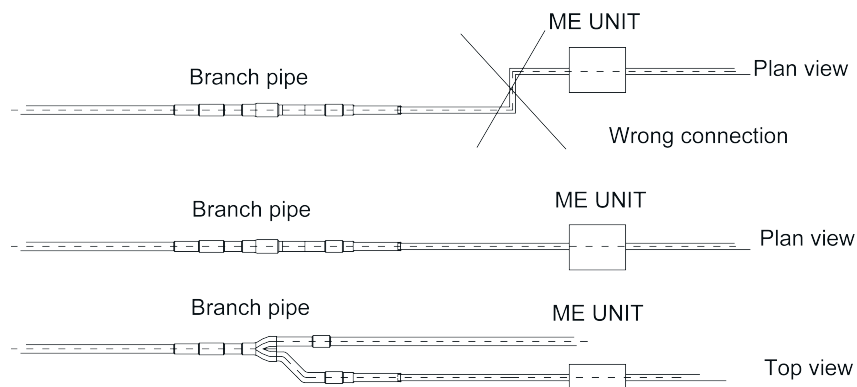

Fig.4.13

**Cautions for Installation**

- (1) The mode exchanger must be installed by using hanger rod. During installation, the components must be kept vertically upright according to the indicated direction;
- (2) During installation, enough space shall be considered for removal of the components. The pipe shall not be jammed between the components.
- (3) The distance of the component to the indoor unit along the pipe shall not be higher than 5000mm (196-7/8inch);
- (4) The mode exchanger and its upstream branch pipe must be installed on the same horizontal plane (See schematics below).



Right connection

Fig.4.14

## 4.2 Pipe Connection

### 4.2.1 Installation instruction for silencer

Connect either left or right side of converter to outdoor unit for piping according to installation space;

(1) Installation instruction for silencer while the right side of converter is connected to outdoor unit;

- 1) Take off the plastic sealing cap in high pressure gas pipe nozzle and liquid pipe nozzle, conduct welding to take off the junction sealing cap in low pressure gas pipe nozzle;

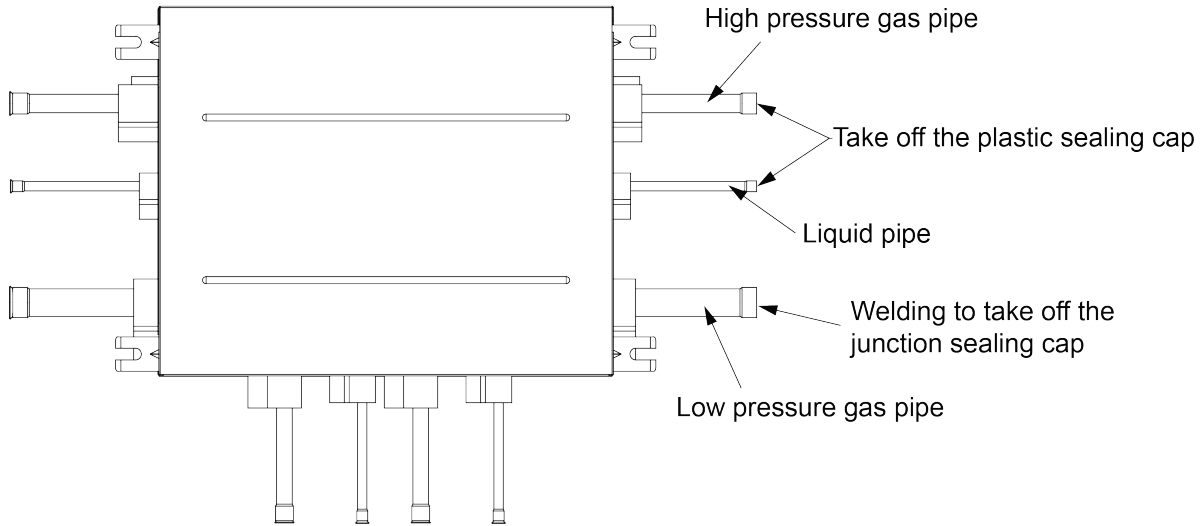

Fig.4.15

- 2) Take out the two silencers, insert nozzle OD $\Phi$ 19mm(3/4inch) in silencer 1 to the high pressure gas pipe on the right side of converter, then insert nozzle OD $\Phi$ 28mm(1-1/8inch) in silencer 2 to the low pressure gas pipe on the right side of converter, conduct welding;

Unit: mm(inch)

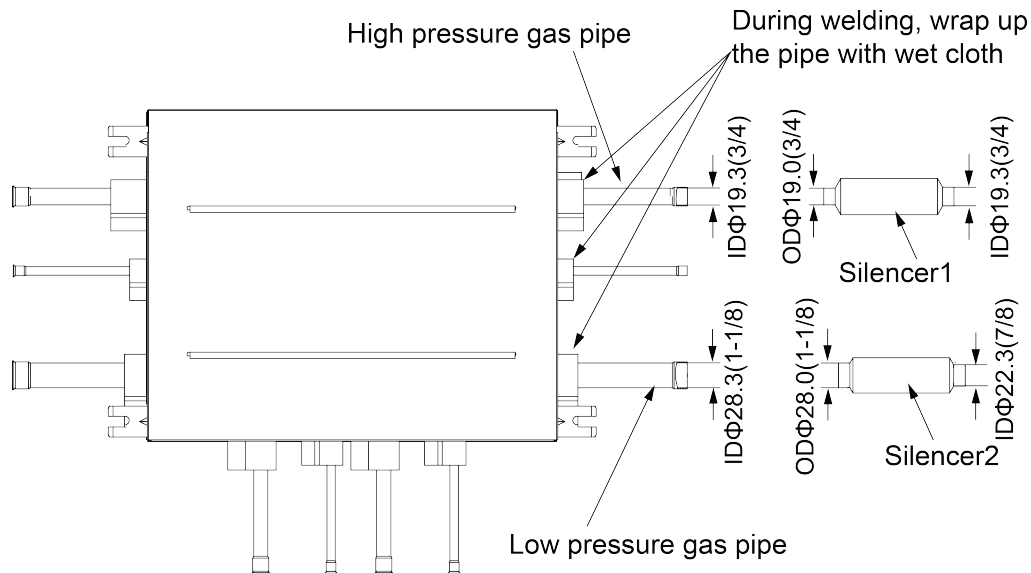

Fig.4.16

#### NOTICE!

During welding, wrap up the pipe with wet cloth (as shown in the Fig.4.16).

- (2) Installation instruction for silencer while the left side of converter is connected to outdoor unit;



- 1) Take off the plastic sealing cap in high pressure gas pipe nozzle and liquid pipe nozzle on the right side of converter and conduct welding and install the two junction sealing caps to block the nozzle on the right;

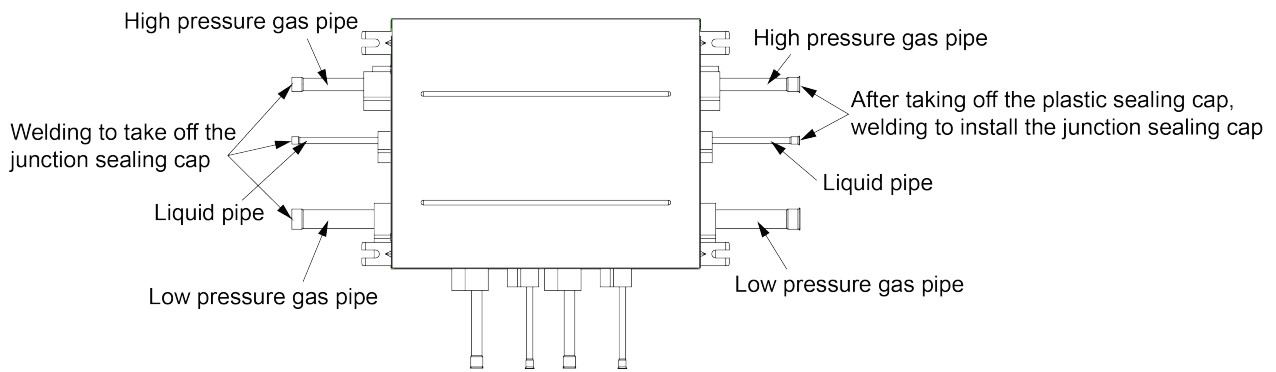

Fig.4.17

- 2) Take out the two silencers, insert nozzle OD $\Phi$ 19mm(3/4inch) in silencer 1 to the high pressure gas pipe on the left side of converter, then insert nozzle OD $\Phi$ 28mm(1-1/8inch) in silencer 2 to the low pressure gas pipe on the left side of converter, conduct welding;

Unit: mm(inch)

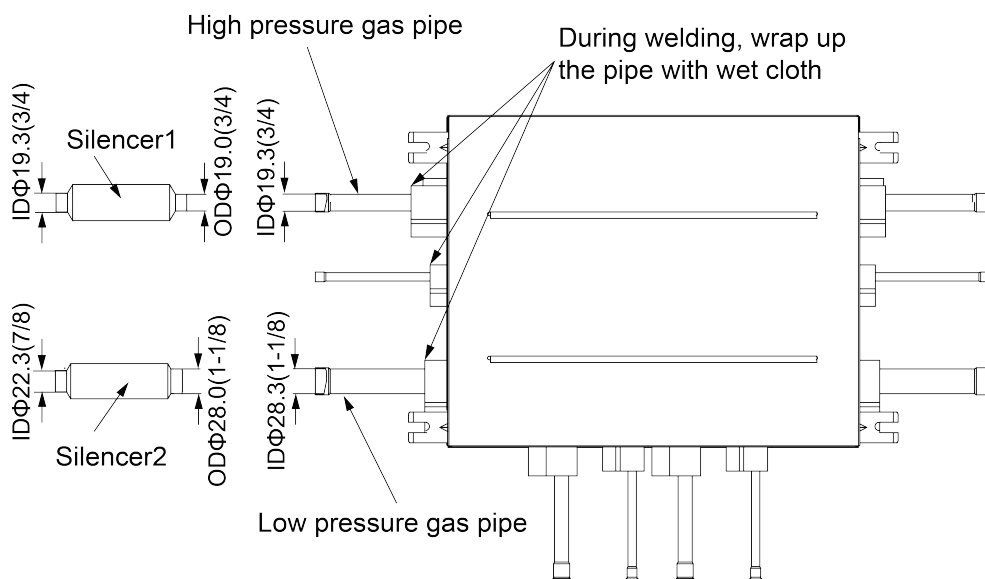

Fig.4.18

**NOTICE!**

During welding, wrap up the pipe with wet cloth (as shown in the Fig.4.18).

**4.2.2 Notices for welding**

- (1) Pipeline connection must adopt socket soldering welding. The gap between socket components cannot be too big or too small to only make sure they won't fall down by relying on friction force.

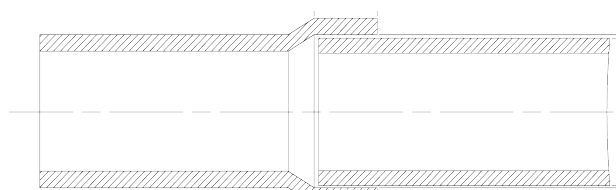

Fig.4.19

- (2) Please note that protect thermal insulating sponge and solenoid valve in the pipeline. Please wrap the pipeline with wet cloth to weld it for protection;
- (3) Before welding the pipeline, please charge nitrogen at first. Nitrogen must be charged for protection during the whole welding process and within 30s after welding is finished. The nitrogen cylinder must be connected to the pressure control valve and the flow speed of nitrogen should be controlled within 4~6L/min (air pressure: 0.02~0.05Mpa). During installation process, please adjust the flow speed of nitrogen by control valve according to the diameter of copper pipe.
- (4) For the unused branch pipelines, they should be sealed with copper tube to avoid leakage of refrigerant in the system.

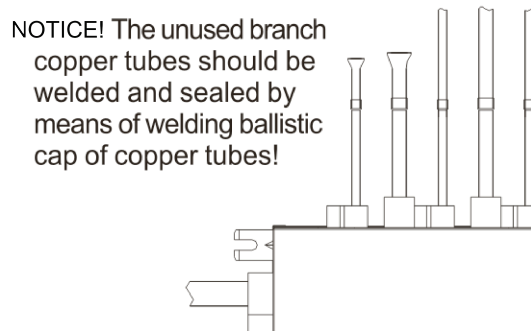

Fig.4.20

#### 4.2.3 Precautions for the Installation of Connection Pipe

- (1) Please comply with the following rules during pipe connection: Connection pipe should be as short as possible, so is the height difference between indoor and outdoor units. Keep the pipe bends as less as possible and the bend radius as large as possible.
- (2) Install the connection pipes by welding. Please strictly follow the requirements for welding process. Rosin joints, weak joints or pin holes are not allowed.
- (3) When laying the pipe, be careful not to distort it. Radius of bending parts must be over 200mm (7-7/8inch). Please do not bend or stretch the pipes frequently, otherwise the pipes will become hard. A pipe shall not be bent or stretched for more than 3 times at the same position.
- (4) Please use moment wrench to connection the union nut of mode exchanger. See below figure.

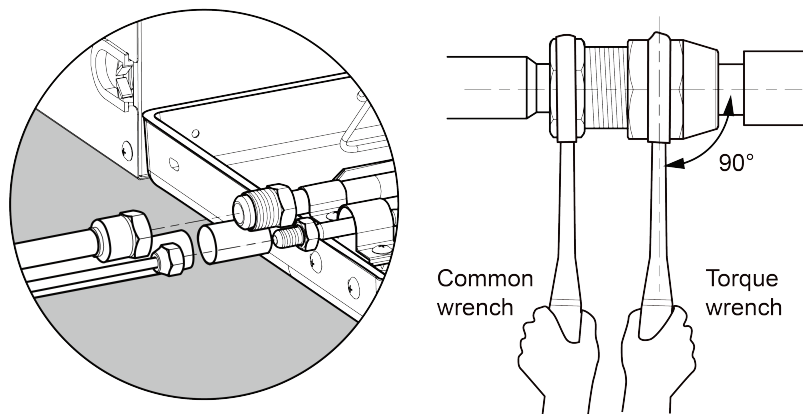

Fig.4.21

- 1) Aim the flared outlet of copper pipe at the center of screwed center, and then rotate the flared nut with hand.
- 2) Use moment wrench to rotate the flared nut until you has head a sound of “KATA”.
- 3) Wrap the connection pipe (not insulated) and joint with sponge and then use plastic adhesive tape to bundle it.
- 4) Support the connection pipe with bracket.
- 5) The degree of curvature of piping can’t be too small, otherwise, the pipe may be broken. Installer should use pipe bender to bend the pipe.
- 6) When connecting mode exchanger and connection pipe, do not pull the big joint and small joint of mode exchanger forcibly. Otherwise, capillary or other pipes of mode exchanger may be broken, which will lead to leakage.

#### 4.2.4 Selection of Y-type branch

If connect outdoor unit to multiple mode exchanger, the Y-type branch should be adopted.

- (1) Y-type branch

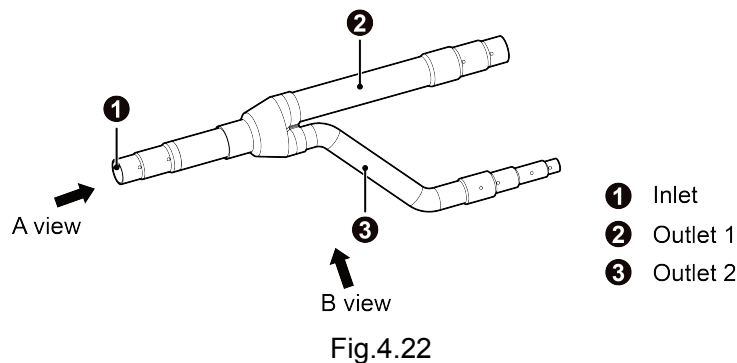

- (2) Y-type branch has several pipe sections with different size, which facilitates to match with various copper pipes. Use pipe cutter to cut in the middle of the pipe section that is of proper size and remove burrs as well. See the following figure.

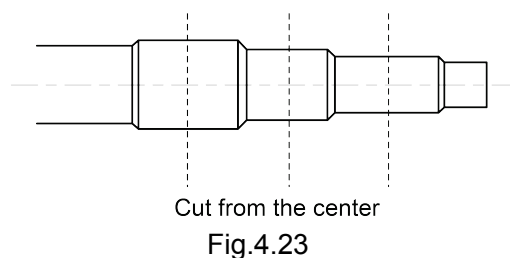

- (3) Y-type branch must be installed vertically or horizontally.

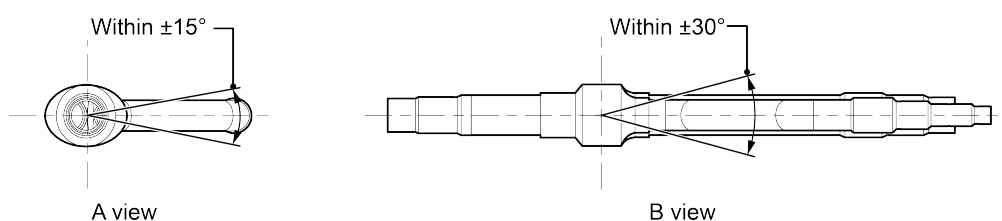

- (4) Branch shall be insulated by insulating material that can bear 120°C(248°F) or even higher temperature. The attached foam of branch cannot be taken as insulating material.

4.2.5 Thermal insulation for pipeline

- (1) For multi VRF system, every copper pipe should be labeled so as to avoid misconnection.
- (2) Manifolds can be laid in the following ways:

The length of a straight pipe between two manifolds cannot be less than 500 mm (19-11/16inch). The length of a straight pipe before the main pipe port of the manifold cannot be less than 500mm (19-11/16inch). The length of a straight pipe between the branch of the manifold and the IDU cannot be less than 500mm(19-11/16inch). See Fig.4.25.

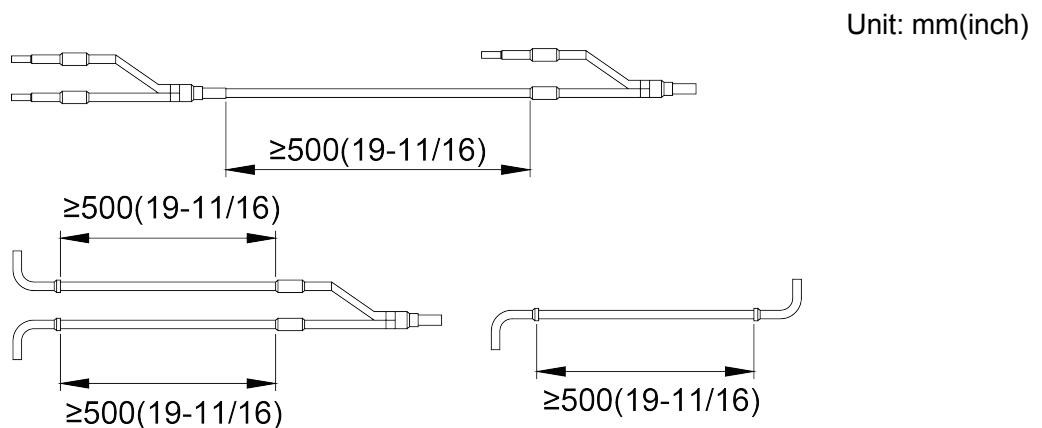

Fig.4.25

- (3) There must be three fixing point for both horizontal and vertical installation of the Y-type manifold. See Fig.4.26.

Fixing point 1: 100mm(4inch) on the main inlet manifold from the welding point

Fixing point 2: 200mm(7-7/8inch) on the main branched pipe from the welding point

Fixing point 3: 250mm(9-13/16inch) on the branched pipe from the welding point

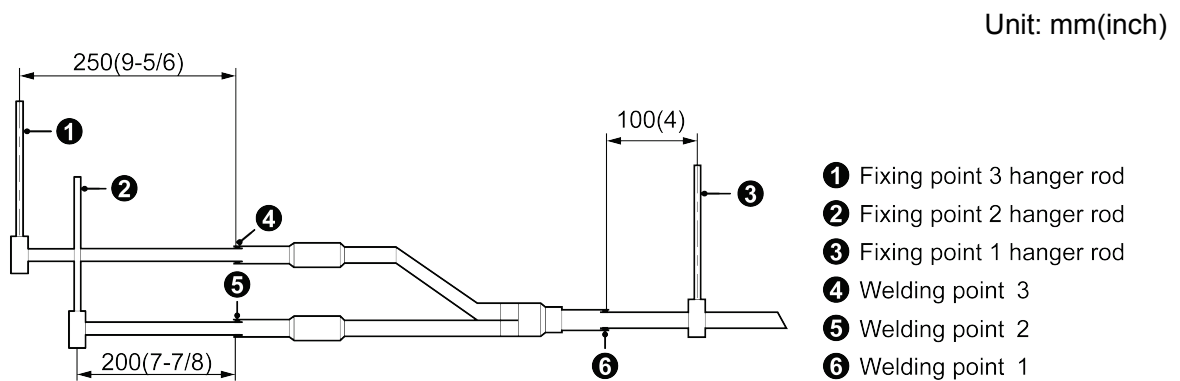

Fig.4.26

(4) Thermal insulation for pipeline

- 1) To avoid condensate or water leak on the connection pipe, the gas pipe and liquid pipe must be wrapped with thermal insulating material and tied by adhesive tape.
- 2) Thermal insulating material shall be able to bear the pipe temperature: For heat pump unit, liquid pipe should bear 70°C(158°F) or above and gas pipe should bear 120°C(248°F) or

above. For cooling only unit, both liquid pipe and gas pipe should bear 70°C(158°F) or above.  
 Example: Polyethylene foam (bear 120°C(248°F) or above); foaming polyethylene (bear 100°C(212°F) or above)

- 3) Joints of indoor and outdoor unit should be wrapped with insulating material and leave no gap to surfaces of indoor unit and outdoor unit. See Fig.4.27, Fig.4.28 and Fig.4.29.

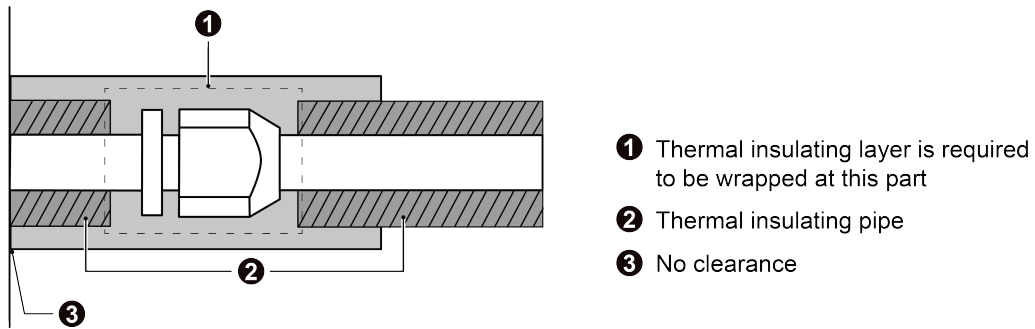

Fig.4.27

Thermal insulating layer is required to be wrapped at this part

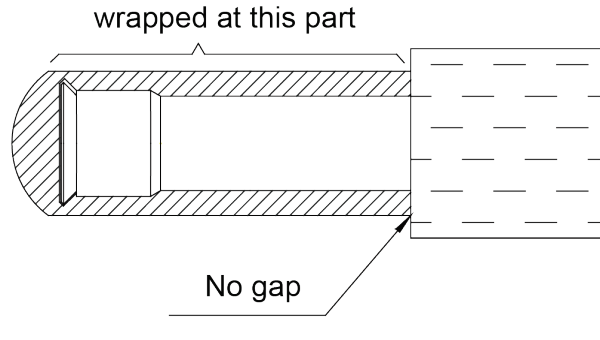

Fig.4.28

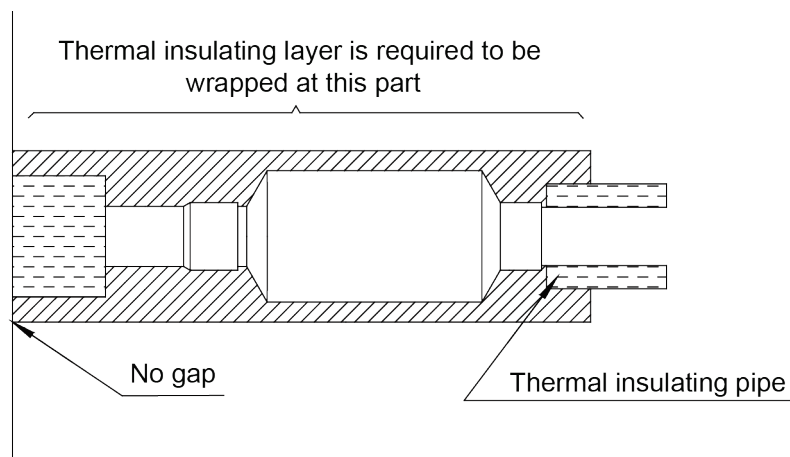

Fig.4.29

- 4) Thermal insulating material of branches should be the same as that of the pipeline. The attached foam of branches cannot be taken as insulating material.
- 5) When wrapping the tape, the later circle should cover half of the former one. Don't wrap the tape too tight, otherwise the insulation effect will be weakened.
- 6) After wrapping the pipe, apply sealing material to completely seal the hole on the wall.

### 4.2.6 Support and protection of pipeline

- (1) Support should be made for hanging connection pipe. Distance between each support cannot be over 1m (39-1/4inch).
- (2) Protection against accidental damage should be made for outdoor pipeline. If pipeline exceeds 1m (39-1/4inch), a pinch plate should be added for protection.

Schematic diagram of piping connection:

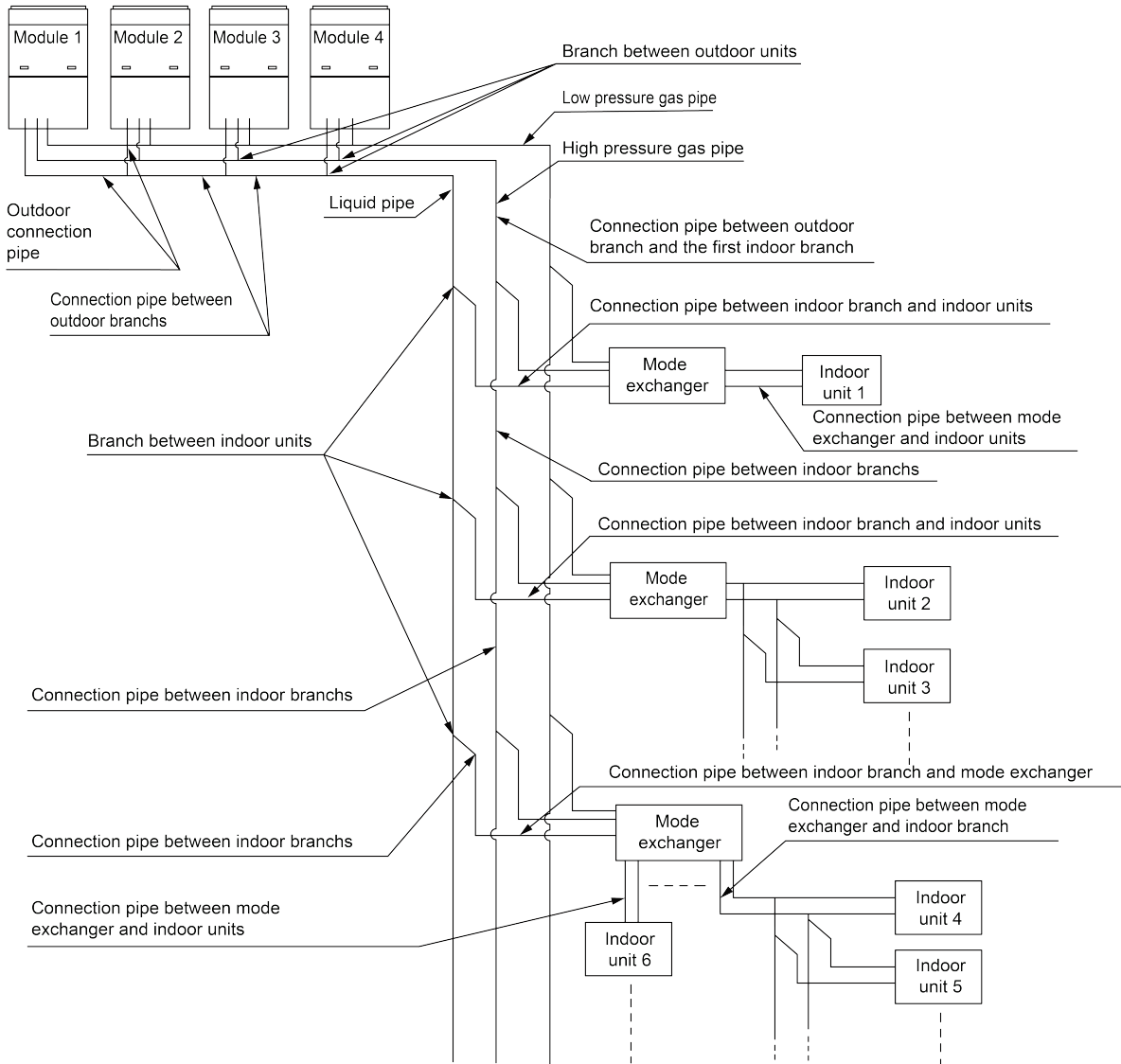

Fig.4.30

### 4.2.7 Size requirement for branch pipe and piping

Take the connection sketch map of single-module system for example.

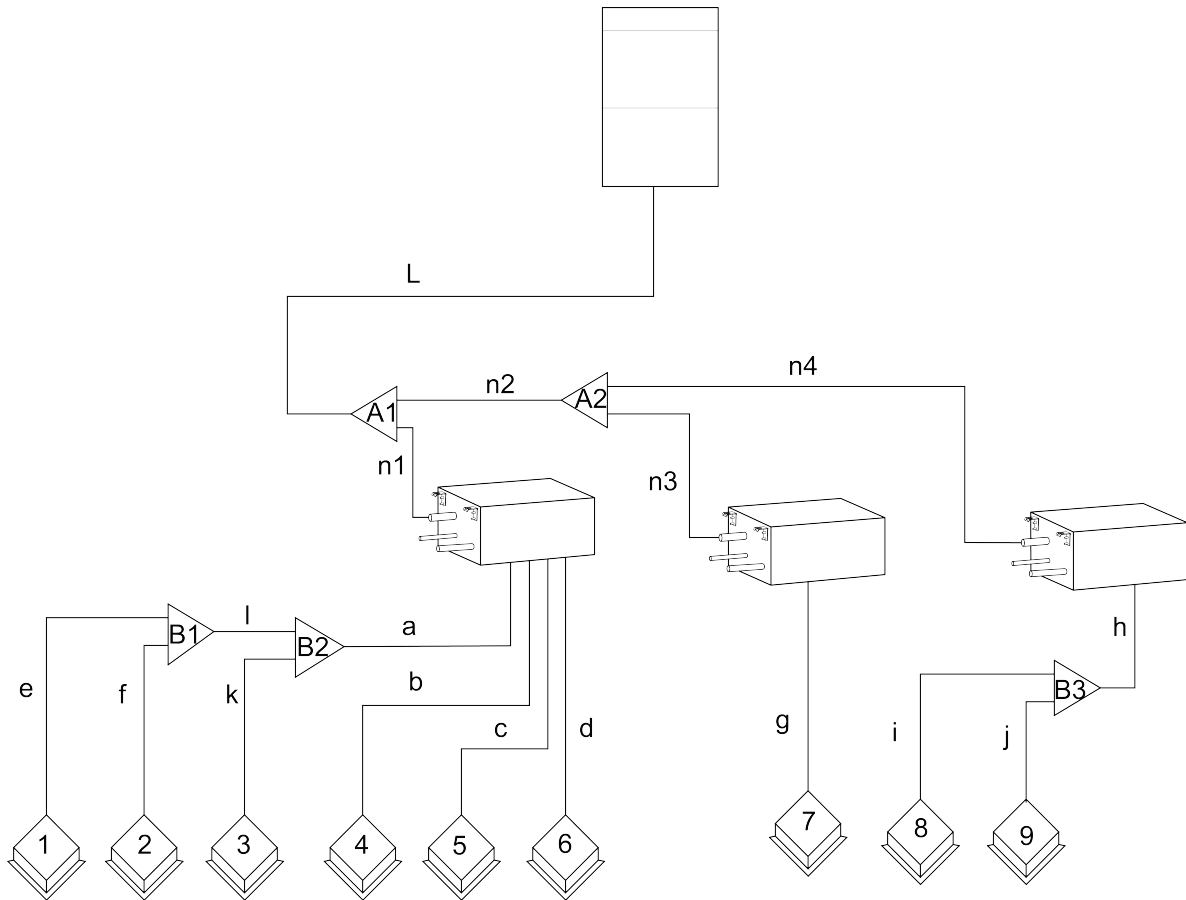

Fig.4.31

#### 4.2.7.1 Branch selection of mode exchanger (“A1, A2”)

Select branch of mode exchanger as per total capacity of downstream indoor unit(s). Please refer to the following table.

Model selection for branch “A1、A2” of mode exchanger;

R410A refrigerant system	Total capacity of the downstream indoor unit X (Btu/h)	Model
Y-Type Branch Pipe	$X \leq 17100$	FQ01Na/A
	$17100 < X \leq 72000$	FQ02Na/A
	$72000 < X \leq 96000$	FQ03Na/A
	$96000 < X \leq 232000$	FQ04Na/A
	$232000 < X \leq 327500$	FQ05Na/A
	$327500 < X$	FQ06Na/A

#### 4.2.7.2 Connection for single indoor unit with capacity of less than 48500Btu/h

Piping size among downstream branches of mode exchanger “a、h、l”

Total rated capacity of downstream indoor units: X (Btu/h)	Piping size among downstream branches of mode exchanger	
	Gas pipe /mm(inch)	Liquid pipe /mm(inch)
$X \leq 9500$	$\Phi 9.52(3/8)$	$\Phi 6.35(1/4)$

## Cooling and Heating Recovery Mode Exchanger

Total rated capacity of downstream indoor units: X (Btu/h)	Piping size among downstream branches of mode exchanger	
	Gas pipe /mm(inch)	Liquid pipe /mm(inch)
9500<X≤17100	Φ12.7(1/2)	Φ6.35(1/4)
17100<X≤48500	Φ15.9(5/8)	Φ9.52(3/8)

Each branch is to connect to a set of indoor units with the same mode. For the branch does not connect to indoor unit, make sure that the welding is reliable without leaking of refrigerant.

Branch selection of downstream indoor unit of mode exchanger (“B1、B2、B3”)

R410A refrigerant system	Total rated capacity of downstream indoor units: X (Btu/h)	Model
Y-type branch	X≤48500	FQ01A/A

Piping size between mode exchanger and downstream indoor unit (“b、c、d、g”)

Total rated capacity of downstream indoor units: X (Btu/h)	Piping size between mode exchanger and downstream indoor unit	
	Gas pipe /mm(inch)	Liquid pipe /mm(inch)
X≤9500	Φ9.52(3/8)	Φ6.35(1/4)
9500<X≤17100	Φ12.7(1/2)	Φ6.35(1/4)
17100<X≤48500	Φ15.9(5/8)	Φ9.52(3/8)

Size of connection pipe between indoor branch and indoor unit should be consistent with the connection pipe of indoor unit.

Piping between indoor branch and indoor unit “e、f、i、j、k”

Rated capacity of indoor units C(Btu/h)	Size of connection pipe between indoor branch and indoor unit	
	Gas pipe /mm(inch)	Liquid pipe /mm(inch)
C≤9500	Φ9.52(3/8)	Φ6.35(1/4)
9500<C≤17100	Φ12.7(1/2)	Φ6.35(1/4)
17100<C≤48500	Φ15.9(5/8)	Φ9.52(3/8)

### 4.2.7.3 Connecting method for indoor unit with capacity of over 48500kBtu/h

When connecting to the indoor unit with capacity of over 48500Btu/h, it is not allowed to connect with only one branch; it must use two branches controlled by the same mainboard for parallel connection.

Parallel connection	Indoor unit Communication connection for mode exchanger	Remarks
Indoor unit No.1 and No.2	“1D1 1D2”	Parallel connection can be conducted only as the combination of this table, it is not allowed to otherwise connect. Note that after the connection, manually set the SA2 dial code of corresponding mainboard, and dial the code in the first place to number end.
Indoor unit No.3 and No.4	“3D1 3D2”	
Indoor unit No.5 and No.6	“5D1 5D2”	
Indoor unit No.7 and No.8	“7D1 7D2”	





Fig.4.32

Connecting method is as shown in the picture:

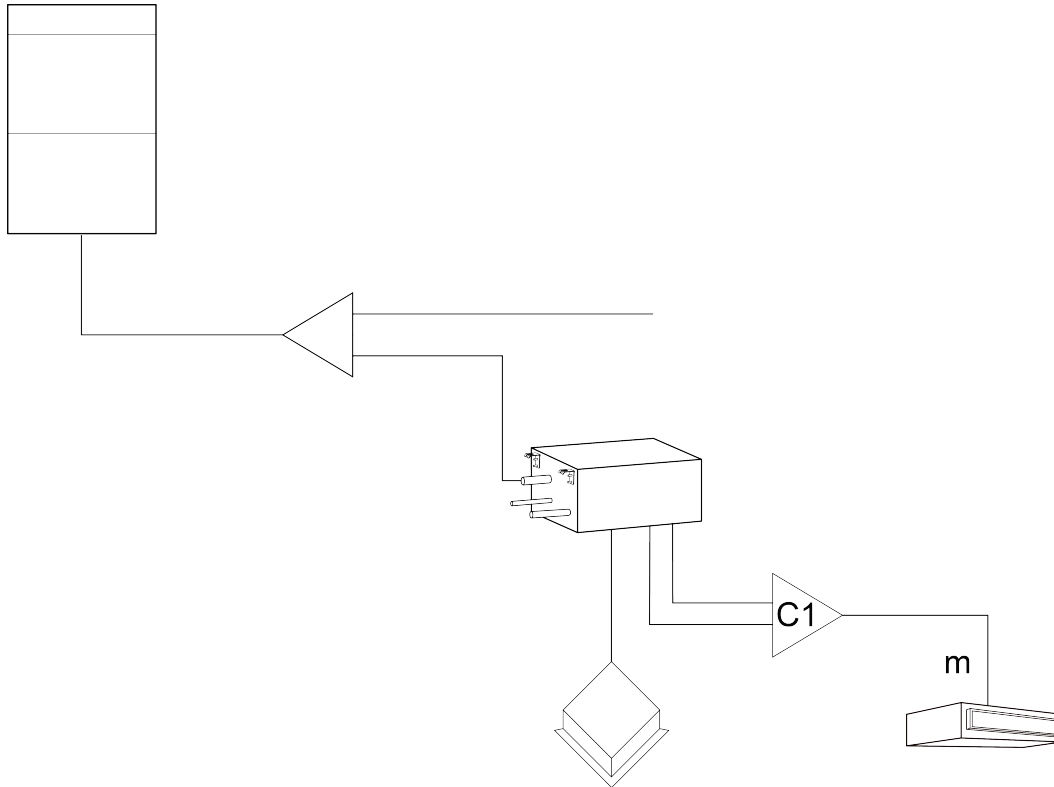

Fig.4.33

4.2.7.4 Branch selection of indoor unit of mode exchanger (“C1”)

R410A refrigerant system	capacity of downstream indoor units: X /Btu/h	Model
Y-type branch	48500<X≤96000	FQ01B/A

4.2.7.5 Piping size between mode exchanger and downstream indoor unit (“m”)

Size of connection pipe between indoor branch and indoor unit should be consistent with the connection pipe of indoor unit.

Piping between indoor branch and indoor unit “m”

Rated capacity of indoor units: c /Btu/h	Size of connection pipe between indoor branch and indoor unit	
	Gas pipe /mm(inch)	Liquid pipe /mm(inch)
48500<c≤72000	Φ19.05(3/4)	Φ9.52(3/8)
72000<c≤96000	Φ22.2(7/8)	Φ9.52(3/8)

### 4.3 Installation and Test for Drainage Hose

#### 4.3.1 Precautions for the Installation of Drainage Hose

- (1) As for the drainage hose, the shorter the better. The drainage hose should be kept 1%~2% at least gradient for draining out the condensate water .
- (2) The side of drainage hose must be bigger than or equal to the size of drainage piping.
- (3) Install the drainage hose according to below figure and then perform thermal insulation for it. Incorrect installation may lead to leakage and then moisten indoor furniture and other objects.
- (4) Purchase the normal hard PVC pipe at local market as for the drainage pipeline. Insert the end part of PVC pipe into the drainage hole, and then tighten it with drainage hose and timeline. Do not use adhesive glue to connect drainage hole and drainage hose.
- (5) When the pipeline is used for multiple units, the position for the common pipeline should be lower than the drain outlet of every unit 100m (3937inch). In this case, thick pipes should be adopted.

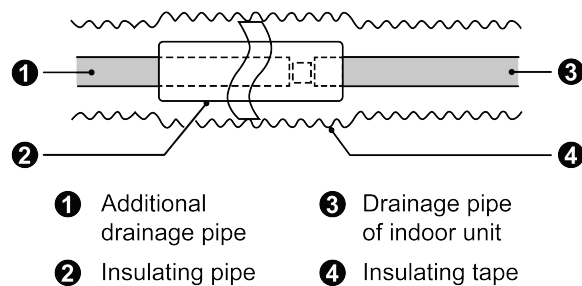

Fig.4.34

#### 4.3.2 Installation of Drainage Hose

- (1) Insert the drainage hose into drain outlet and then bundle it with adhesive tape, as shown in Fig.4.35. Model with water pump will be provided with drain hose, while other models please prepare the drain hose by yourself.

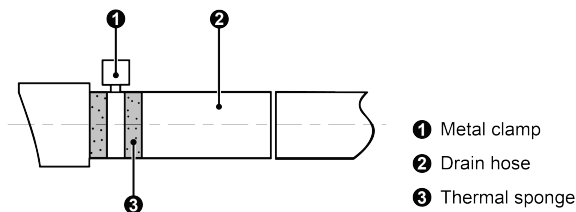

Fig.4.35

- (2) Tighten the pipe clamp to make the distance between screw cap and hose less than 4mm (3/16inch).
- (3) Perform thermal insulating for Pipe clamp and hose with gasket. (perform the thermal insulation after the drainage system test as shown in Fig.4.36 is finished).

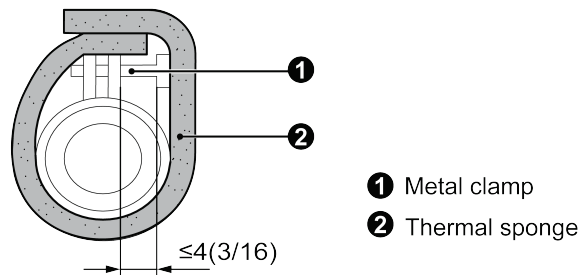

Fig.4.36

(4) When multiple drainage pipes are connected together, connection pipes as shown in Fig.4.37.

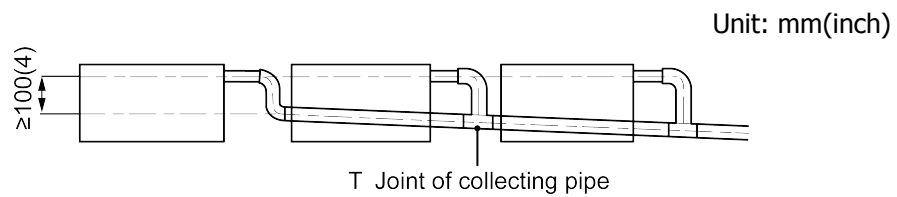

Fig.4.37

- (5) Install the U-trap as shown in Fig.4.38.
- (6) One U-trap should be installed for every unit.
- (7) Convenient clean should be considered when installing U-trap.

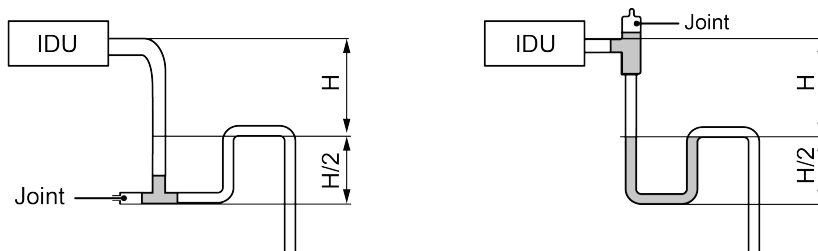

Fig.4.38

(8) Horizontal pipe can't be connected to the vertical pipe at the same horizontal height. Please see below figure for the connection method:

- No1: Three-way connection of drainage hose joint as shown in Fig.4.39;
- No2: Down elbow connection as shown in Fig.4.40;
- No3: Set into horizontal pipe as show in Fig.4.41.

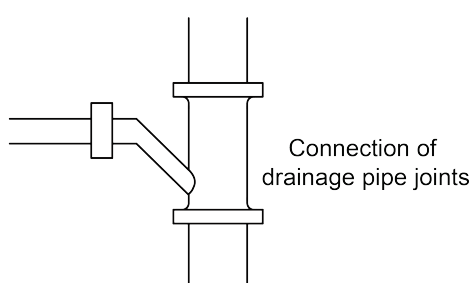

Fig.4.39

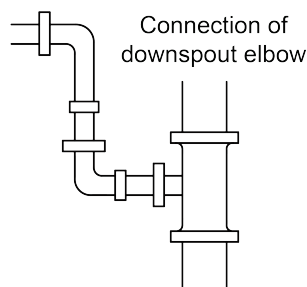

Fig.4.40

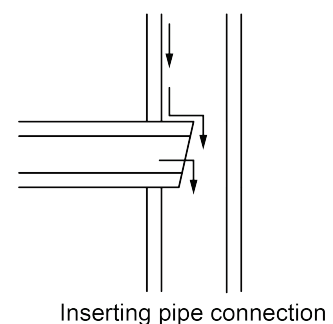

Fig.4.41

(9) Drainage pipe should kept 1%~2% gradient downwards. Therefore, install a support bracket every 1000-1500mm (39-3/8-59inch).

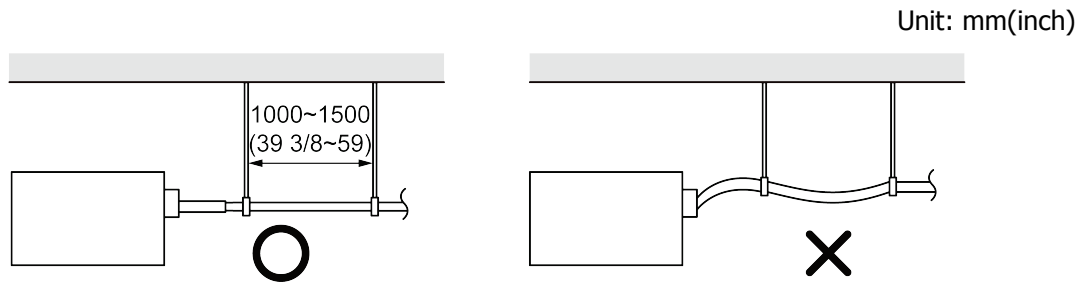

Fig.4.42

## 5 Cable Connection

<b>⚠ CAUTION</b>
① Air conditioner must be grounded for preventing damage due to invalid insulation.
② Before connecting wires, please confirm the voltage on the nameplate and then connect wires according to wiring diagram. Wrong wire connection may lead to abnormal operation or damage to the air conditioner.
③ Power capacity should be enough and then section area of wires should be 2.5 mm <sup>2</sup> (0.0039sq.inch) above.
④ As for the air conditioner power, please use special branch circuit and socket.
⑤ Perform wiring according to standard to ensure normal operation of air conditioner.
⑥ According to related regulation and electric appliances standard, install special branch circuit breaker.
⑦ All wiring must use pressure terminal or single wire. If connect the stranded wire to the wiring board directly, it may cause fire.
⑧ Do not let cable connect refrigerant pipe and compressor or fan.
⑨ Do not modify the internal wiring of air conditioner. Manufacturer will not responsible for the damage or abnormal operation because of that.
⑩ If there's stronger electromagnetic interference around the installation environment, you are suggested to use twisted shielding wire. When connecting wires, please note that the metal shielding layer of twisted pair wire must be grounded (case) to prevent abnormal operation due to electromagnetic interference.
⑪ Communication wire must be separated from power cord and outdoor/indoor unit connection wires.
⑫ When higher pressure is need for the project, please set it through wired controller. The appliance shall be installed in accordance with national wiring regulation. If the supply cord is damaged, it must be replaced by the manufacturer or its service agent or a similarly qualified person in order to avoid a hazard.

### 5.1 Connection of Cable and Terminal of Wiring Board

- (1) Connect single wire (as shown in Fig.5.1).
  - 1) Peel the insulation layer at the end of the single wire about 25mm(1inch) with wire stripper to expose the single-core wire.
  - 2) Use screwdriver to remove the terminal screw on wiring terminal board.
  - 3) Bend the terminal of single wire with pliers to a round circle whose dimension comply with the screw.
  - 4) Hold the screw to pass it through the round circle of single wire and then fix it at the wiring board.
- (2) Connect stranded wire (as shown in Fig.5.2).
  - 1) Peel the insulation layer at the end of the stranded wire about 10mm (3/8 inch).
  - 2) Remove the screws on the wiring board of air conditioner with screwdriver.

- 3) Use round terminal fastener or pliers to clip round terminal and every core wire of multi-core wire tightly.
- 4) Confirm the position of every core-wire on round terminal and then use screwdriver to tighten the screws of wiring terminal.

Unit: mm(inch)

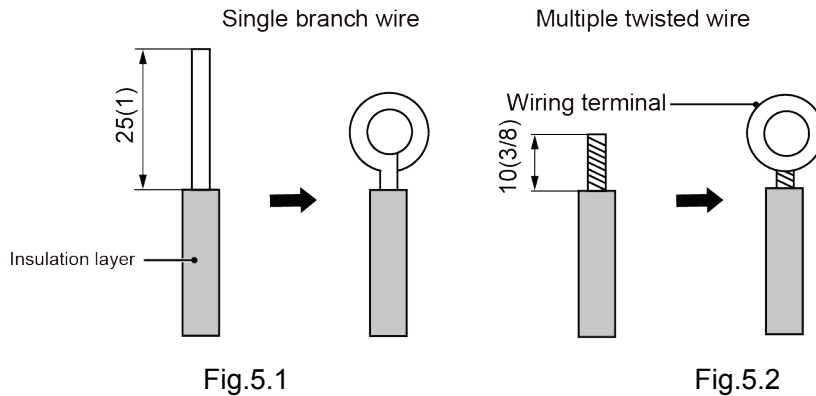

## 5.2 Connect Power Cord

**NOTICE!** The mode exchanger in the same system must be supplied power uniformly.

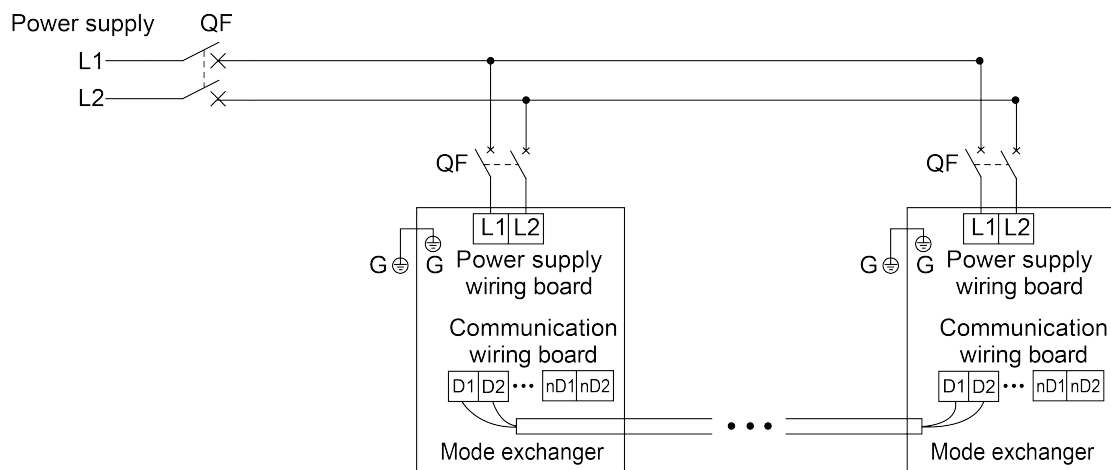

Fig.5.3

Remark: The maximum quantity “n” of indoor unit is decided by the capacity of indoor unit, please refer to capacity of unit.

- (1) Use single-phase power air conditioner
  - 1) Remove electric box cover of indoor unit.
  - 2) Pass the power cord through rubber ring.
  - 3) Connect power cord to “L1, L2” terminal and earthing screw. Please use the green bonding screw to connect the earthing cord. The location is showing in the Fig.5.4

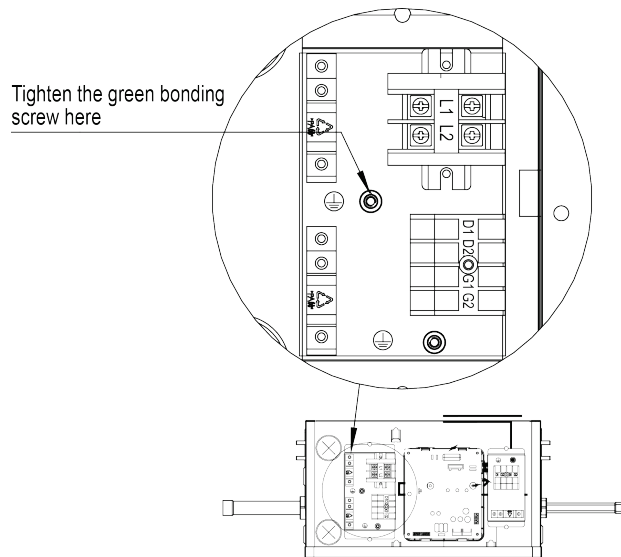

Fig.5.4

4) Fix the power cord with wire-fixing clamp.

5) Take off the cable cross loop that is attached to the mode exchanger, as shown in Fig.5.5~5.8.

Replace with a local cable cross bushing.

One-to-one Cooling and Heating Mode Exchanger

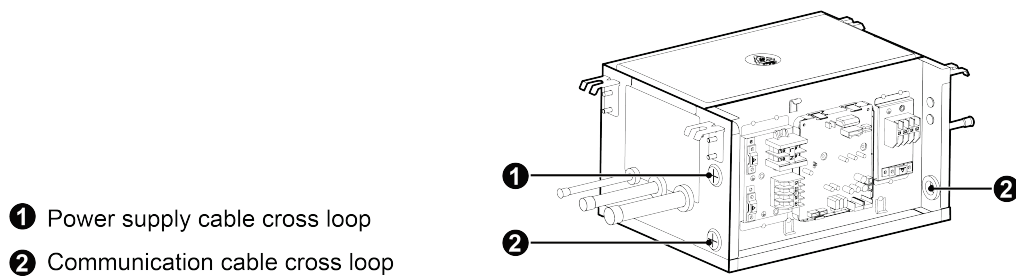

Fig.5.5

One-to-two Cooling and Heating Mode Exchanger

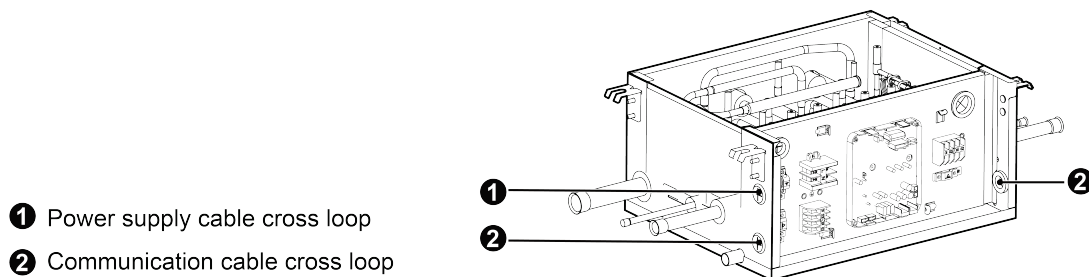

Fig.5.6

One-to-four Cooling and Heating Mode Exchanger

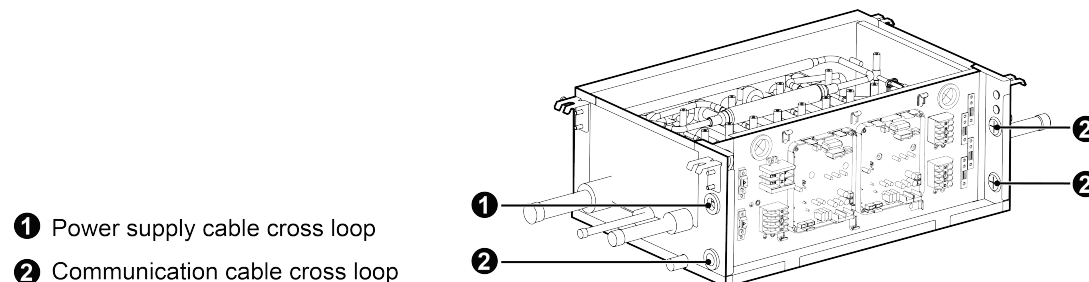

Fig.5.7

## One-to-eight Cooling and Heating Mode Exchanger

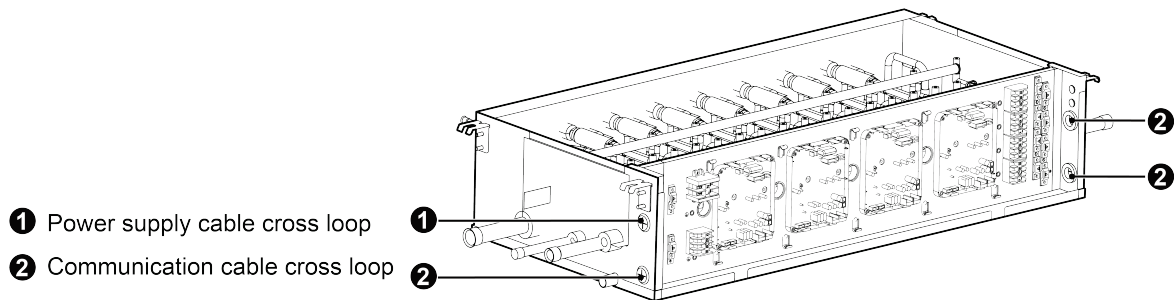

Fig.5.8

## 5.3 Connect Communication Wire of Indoor Unit and Outdoor Unit

- (1) Open electric box cover of indoor unit.
- (2) Pass the communication wire through rubber ring.
- (3) Connect communication wire to wiring board OD(D1, D2) of outdoor unit of mode exchanger.
- (4) Connect communication wire lead from D1 and D2 terminal of 4-bit wiring board of indoor unit to wiring board ID1(1D1, 1D2) of indoor unit of mode exchanger; ID2(2D1, 2D2.....ID-n(nD1, nD2),  $n \leq 8$ , As shown in Fig.5.10

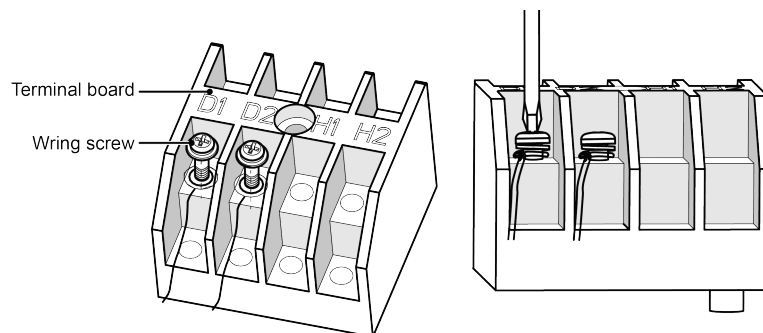

Fig.5.9

- (5) Fix the communication wire with wire-fixing clamp.
- (6) In order to ensure the reliability of communication between indoor unit and outdoor unit, add a matched resistance (in the packing bag) on the wiring board at the last connected mode exchanger. The matched resistance should be connected among terminal screw D1 and D2.
- (7) When mode converter connects to the indoor unit with capacity of over 48500Btu/h, it only requires to connect the indoor unit to one of the two corresponding branch. Note that the first place in the SA2 dial code for corresponding mainboard of the two branches is dialed to number end.

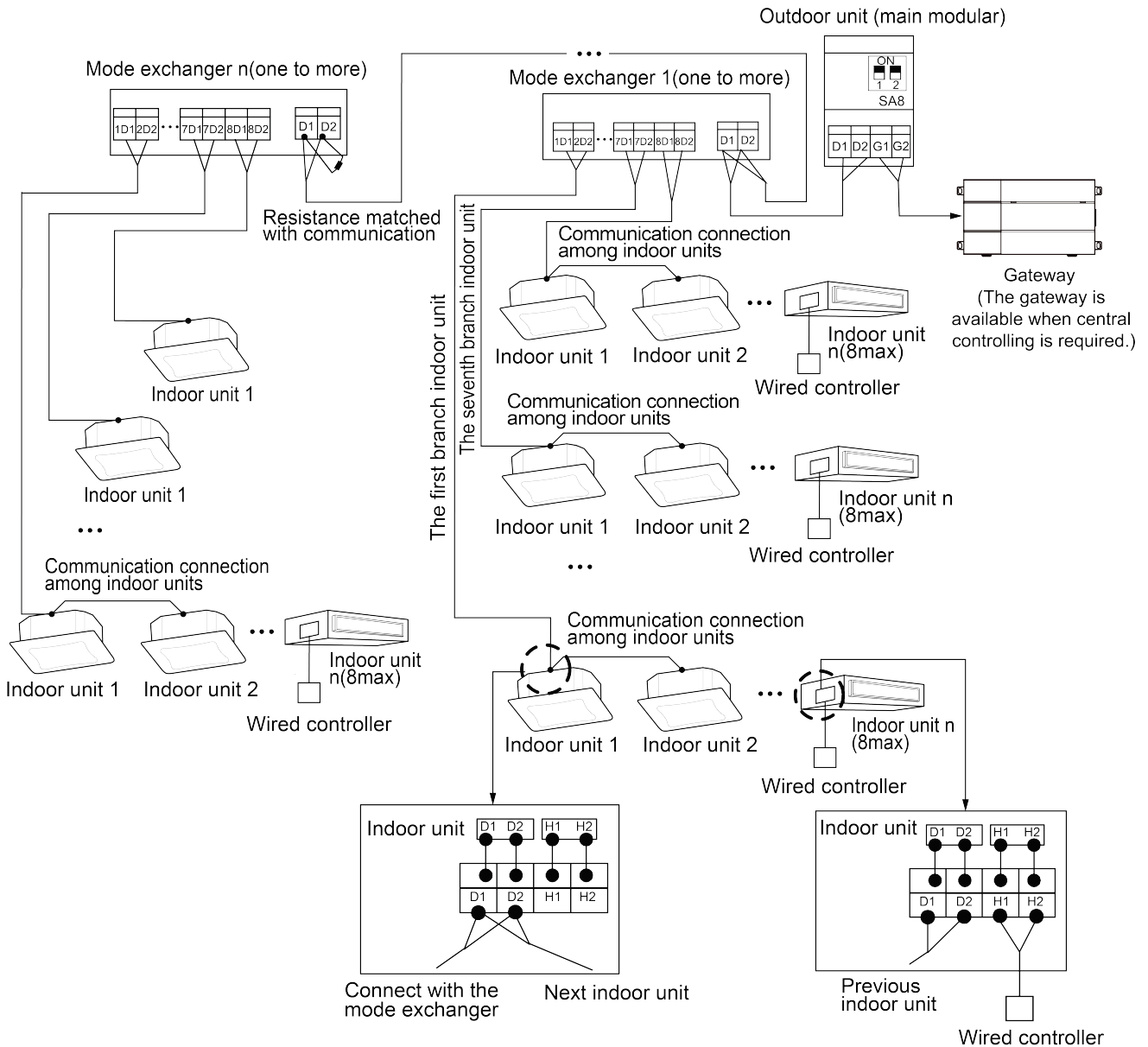

Fig.5.10

## 6 Routine Maintenance

<b>⚠ CAUTION</b>	
①	Only clean the air conditioner after turning off the unit and cutting off the power. Otherwise, it may cause electric shock or injury.
②	When cleaning the air conditioner, please stand on the solid platform.
③	Do not use hot water 45°C (113°F) above to clean the surface of air conditioner. Otherwise, it may cause discolor or deformation.
④	Do not dry the filter on fire. Otherwise, the filter may catch fire or be deformed.
⑤	Volatile liquid, such as thinner or gasoline, may damage the air conditioner. (Only use soft dry cloth or wet cloth dipped with neutral detergent to clean the filter of air conditioner.)
⑥	If there's abnormal phenomenon, please contact after-sales person.

### 6.1 Notice before Seasonal Use

- (1) Check whether air inlets and air outlets of indoor and outdoor units are blocked;
- (2) Check whether ground connection is reliable or not;



- (3) Check whether the wires are connected well;
- (4) After getting through power, check whether there're characters on the screen of wire controller.

## 6.2 Maintenance after Seasonal Use

- (1) Run the air conditioner at fan mode for half day at sunny day to dry the internal parts of unit.
- (2) If you don't use the air conditioner for a long time, please cut off the power to save energy; after cutting off the power, the characters on the screen of wire controller will disappear.

## 7 Troubleshooting

If the air conditioner can't operate normally, please check below items before asking for service:

Malfunction	Causes
Air conditioner can't be started up	<ol style="list-style-type: none"> <li>① It hasn't been put through power</li> <li>② Leakage switch is tripped</li> <li>③ Voltage is too low</li> <li>④ Working buttons are off</li> <li>⑤ Malfunction of control loop</li> </ol>
Air conditioner can operate, but it will stop operate after for a while	<ol style="list-style-type: none"> <li>① There's obstacle in front of condenser</li> <li>② Control loop is abnormal</li> <li>③ Turn on the cooling mode when the outdoor ambient temperature is more than 43°C(109.4°F)</li> </ol>
Cooling effect is bad	<ol style="list-style-type: none"> <li>① Air filter is dirty or blocked</li> <li>② There are heat source or too many people in the room</li> <li>③ Door or winder is open</li> <li>④ There're obstacles at air inlet and air outlet</li> <li>⑤ Set temperature is too high or refrigerant is leaking</li> <li>⑥ Specification of room temperature sensor is not good</li> </ol>
Heating effect is bad	<ol style="list-style-type: none"> <li>① Air filter is dirty or blocked</li> <li>② Door or window is not closed well</li> <li>③ Set temperature is too low</li> <li>④ Refrigerant is leaking</li> <li>⑤ Outdoor ambient temperature is lower than -5°C(23°F)</li> <li>⑥ Control wiring is abnormal</li> </ol>
Indoor fan can't be started up under heating mode	<ol style="list-style-type: none"> <li>① The installation position for the tube temperature sensor is not proper</li> <li>② Tube temperature sensor is not inserted well</li> <li>③ Wires for tube temperature sensor is broken</li> <li>④ Capacitor is leaking</li> </ol>

### NOTICE !

After checking above items, if the air conditioner still can't operate normally, please stop the air conditioner immediately and then contact appointed maintenance center.

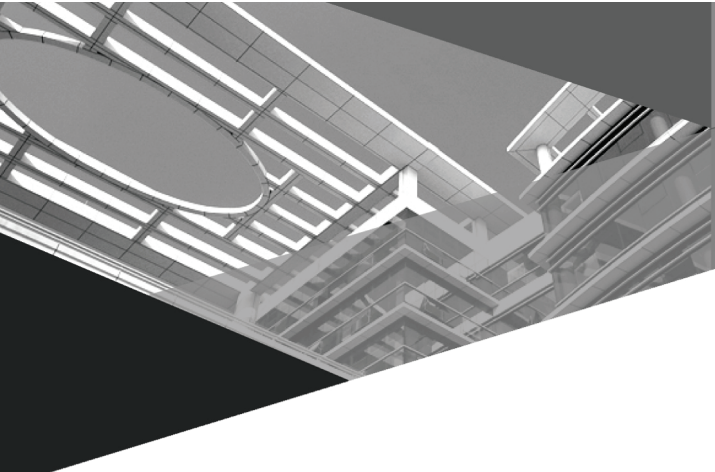

GREE ELECTRIC APPLIANCES, INC. OF ZHUHAI

Add: West Jinji Rd, Qianshan, Zhuhai, Guangdong, China, 519070

Tel: (+86-756) 8522218

Fax: (+86-756) 8669426

E-mail: [global@cn.gree.com](mailto:global@cn.gree.com) [www.gree.com](http://www.gree.com)



66170050113