



## Ultra Heat GMV Multi VRF Units Heat Recovery Serial

Owner' s Manual

Air Conditioners



GMV-VQ72W/A-F(U)  
GMV-VQ96W/A-F(U)  
GMV-VQ144WM/A-F(U)  
GMV-VQ168WM/A-F(U)  
GMV-VQ192WM/A-F(U)



Thank you for choosing Air Conditioners, please read this owner's manual carefully before operation and retain it for future reference. If you have lost the Owner's Manual, please contact the local agent or visit [www.gree.com](http://www.gree.com) or sent email to [global@gree.com.cn](mailto:global@gree.com.cn) or electronic version.

GREE reserves the right to interpret this manual which will be subject to any change due to product improvement without further notice.

GREE Electric Appliances, Inc. of Zhuhai reserves the final right to interpret this manual.

## Preface

Gree Ultra Heat GMV Multi VRF System, with the most advanced technologies in the world, uses eco-friendly refrigerant R410A as its cooling medium. For correct installation and operation, please read this manual carefully.

	This is the safety alert symbol. It is used to alert you to potential personal injury hazards. Obey all safety messages that follow this symbol to avoid possible injury or death.
 <b>WARNING</b>	This mark indicates procedures which, if improperly performed, might lead to the death or serious injury of the user.
 <b>CAUTION</b>	This mark indicates procedures which, if improperly performed, might possibly result in personal harm to the user, or damage to property.
<b>NOTICE</b>	NOTICE is used to address practices not related to personal injury.

 <b>WARNING</b>	
(1)	Instructions for installation and use of this product are provided by the manufacturer.
(2)	Installation must be performed in accordance with the requirements of NEC and CEC by authorized personnel only.
(3)	For safety operation, please strictly follow the instructions in this manual.
(4)	During operation, the gross rated capacity of working IDU should be within the gross rated capacity of ODU. Otherwise, IDU's cooling/heating performance will be reduced.
(5)	This manual must be in the hands of direct operators or maintenance men.
(6)	In case of malfunction and operation failure, please examine the following items and contact our authorized service centers as soon as possible. 1) Nameplate (model, cooling capacity, product code, ex-factory date). 2) Malfunction status (detail description of conditions before and after malfunction occurs)
(7)	All units have been strictly tested and proved to be qualified before ex-factory. To avoid unit damage or even operation failure which may be caused by improper disassembly, please do not disassemble units by yourself. If disassembly is needed, please contact our authorized service centers for help.
(8)	All graphics and information in this manual are only for reference. Manufacturer reserves the right for changes in terms of sales or production at any time and without prior notice.
(9)	If the supply cord is damaged, it must be replaced by the manufacturer, its service agent or similarly qualified persons in order to avoid a hazard.

This appliance can be used by children aged from 8 years and above and persons with reduced physical, sensory or mental capabilities or lack of experience and knowledge if they have been given supervision or instruction concerning use of the appliance in a safe way and understand the hazards involved. Children shall not play with the appliance. Cleaning and user maintenance shall not be made by children without supervision.



**DISPOSAL:** Do not dispose this product as unsorted municipal waste. Collection of such waste separately for special treatment is necessary.

<b>Exception Clauses</b>
Manufacturer will bear no responsibilities when personal injury or property loss is caused by the following reasons:
(1) Damage the product due to improper use or misuse of the product;
(2) Alter, change, maintain or use the product with other equipment without abiding by the instruction manual of manufacturer;
(3) After verification, the defect of product is directly caused by corrosive gas;
(4) After verification, defects are due to improper operation during transportation of product;
(5) Operate, repair, maintain the unit without abiding by instruction manual or related regulations;
(6) After verification, the problem or dispute is caused by the quality specification or performance of parts and components that produced by other manufacturers;
(7) The damage is caused by natural calamities, bad using environment or force majeure.

# Contents

<b>1 Safety Precautions.....</b>	<b>1</b>
<b>2 Product Introduction.....</b>	<b>3</b>
2.1 Names of Main Parts.....	3
2.2 Combinations of Outdoor Units.....	3
2.3 Combinations of Indoor and Outdoor Units.....	3
2.4 The Range of Production Working Temperature.....	4
<b>3 Preparation before Installation.....</b>	<b>5</b>
3.1 Standard Parts.....	5
3.2 Installation Site.....	5
3.3 Piping Work Requirements.....	10
<b>4 Installation Instruction.....</b>	<b>11</b>
4.1 ODU Foundation.....	11
4.2 Physical Dimension of the Outdoor Unit and Mounting Hole.....	12
4.3 Connection Pipe.....	13
4.4 Installation of the Connection Pipe.....	20
4.5 Air Purging and Refrigerant Charge.....	24
4.6 Electric Wiring.....	27
4.7 System Communication.....	30
4.8 Connection Method and Steps for System Communication.....	34
4.9 External Electrical Wiring Diagram.....	41
4.10 Attention before operation.....	43
<b>5 Check Items after Installation and Trial Run.....</b>	<b>45</b>
5.1 Check Items after Installation.....	45
5.2 Trial Run.....	45
<b>6 Common Malfunctions and Troubleshooting.....</b>	<b>55</b>
<b>7 Error Indication.....</b>	<b>57</b>
<b>8 Maintenance and Care.....</b>	<b>62</b>
8.1 Outdoor Heat Exchanger.....	62
8.2 Drain Pipe.....	62
8.3 Notice before Seasonal Use.....	62
8.4 Maintenance after Seasonal Use.....	62
8.5 Parts Replacement.....	62
<b>9 After-sales Service.....</b>	<b>63</b>

# 1 Safety Precautions



- |  |
|--|
|  |
| (1) This product can't be installed at corrosive, inflammable or explosive environment or the place with special requirements, such as kitchen. Otherwise, it will affect the normal operation or shorten the service life of the unit, or even cause fire hazard or serious injury. As for above special places, please adopt special air conditioner with anti-corrosive or anti-explosion function. |
| (2) Follow this instruction to complete the installation work. Please carefully read this manual before unit startup and service.  |
| (3) Wire size of power cord should be large enough. The damaged power cord and connection wire should be replaced by exclusive cable.  |
| (4) After connecting the power cord, please fix the electric box cover properly in order to avoid accident.  |
| (5) Never fail to comply with the nitrogen charge requirements. Charge nitrogen when welding pipes.  |
| (6) Never short-circuit or cancel the pressure switch to prevent unit damage.  |
| (7) Please firstly connect the wired controller before energization, otherwise wired controller cannot be used.  |
| (8) Before using the unit, please check if the piping and wiring are correct to avoid water leakage, refrigerant leakage, electric shock, or fire etc.   |
| (9) Do not insert fingers or objects into air outlet/inlet grille.   |
| (10) Open the door and window and keep good ventilation in the room to avoid oxygen deficit when the gas/oil supplied heating equipment is used.   |
| (11) Never start up or shut off the air conditioner by means of directly plug or unplug the power cord.  |
| (12) Turn off the unit after it runs at least five minutes; otherwise it will influence oil return of the compressor.  |
| (13) Do not allow children operate this unit.  |
| (14) Do not operate this unit with wet hands.  |
| (15) Turn off the unit or cut off the power supply before cleaning the unit, otherwise electric shock or injury may happen.  |
| (16) Never spray or flush water towards unit, otherwise malfunction or electric shock may happen.  |
| (17) Do not expose the unit to the moist or corrosive circumstances.   |
| (18) Under cooling mode, please don't set the room temperature too low and keep the temperature difference between indoor and outdoor unit within 5° C(41° F).   |
| (19) User is not allowed to repair the unit. Fault service may cause electric shock or fire accidents. Please contact Gree appointed service center for help.  |
| (20) Before installation, please check if the power supply is in accordance with the requirements specified on the nameplate. And also take care of the power safety.  |

(21) Installation should be conducted by dealer or qualified personnel. Please do not attempt to install the unit by yourself. Improper handling may result in water leakage, electric shock or fire disaster etc.
(22) Be sure to use the exclusive accessory and part to prevent the water leakage, electric shock and fire accidents.
(23) Make sure the unit can be earthed properly and soundly after plugging into the socket so as to avoid electric shock. Please do not connect the ground wire to gas pipe, water pipe, lightning rod or telephone line.
(24) Electrify the unit 8 hours before operation. Please switch on for 8 hours before operation. Do not cut off the power when 24 hours short-time halting (to protect the compressor).
(25) If refrigerant leakage happens during installation, please ventilate immediately. Poisonous gas will emerge if the refrigerant gas meets fire.
(26) Volatile liquid, such as diluent or gas will damage the unit appearance. Only use soft cloth with a little neutral detergent to clean the outer casing of unit.
(27) If anything abnormal happens (such as burning smell), please power off the unit and cut off the main power supply, and then immediately contact Gree appointed service center. If abnormality keeps going, the unit might be damaged and lead to electric shock or fire.
(28) When the external heat exchanger or the air outlet are covered by ice or snow, be sure to clear the ice or snow before starting the operation, otherwise it will damage the unit or invalid operation.

GREE will not assume responsibility of personal injury or equipment damage caused by improper installation and commission, unnecessary service and incapable of following the rules and instructions listed in this manual.

## 2 Product Introduction

Gree Ultra Heat GMV Multi VRF Modular System (heat recovery serial) adopts inverter compressor technology. According to change the displacement of compressor, step less capacity regulation within range of 10%-100% can be realized. Various product lineup is provided with capacity range from 72K Btu to 192K Btu, which can be widely used in working area and especially applicable to the place with variable load change. Gree air conditioner is absolutely your best choice.

### 2.1 Names of Main Parts

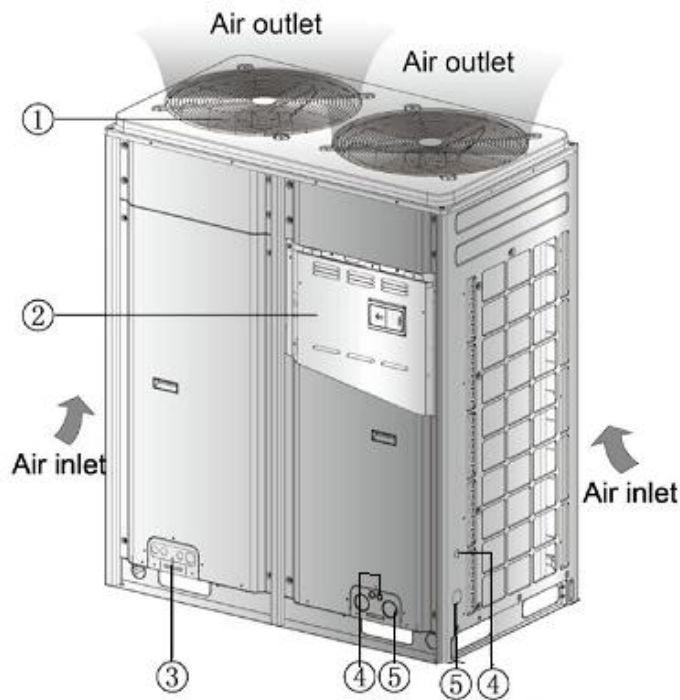

Fig.1

NO.	①	②	③	④	⑤
Name	Fan, Motor	Electric Box Assembly	Valve interface	Communication code through-hole	Power cord through-hole

### 2.2 Combinations of Outdoor Units

Single Model	GMV-VQ144WM/A-F(U)	GMV-VQ168WM/A-F(U)	GMV-VQ192WM/A-F(U)
Combined Model	GMV-VQ72W/A-F(U)+ GMV-VQ72W/A-F(U)	GMV-VQ72W/A-F(U)+ GMV-VQ96W/A-F(U)	GMV-VQ96W/A-F(U)+ GMV-VQ96W/A-F(U)

### 2.3 Combinations of Indoor and Outdoor Units

ODU Model	Max number of connectable IDU (unit)
GMV-VQ72W/A-F(U)	12

GMV-VQ96W/A-F(U)	17
GMV-VQ144WM/A-F(U)	24
GMV-VQ168WM/A-F(U)	29
GMV-VQ192WM/A-F(U)	34

The total capacity of indoor units should be within 50%~135% of that of outdoor units. While the rate is over 100% and all IDUs are on run, the units cooling or heating capacity will be wakened.

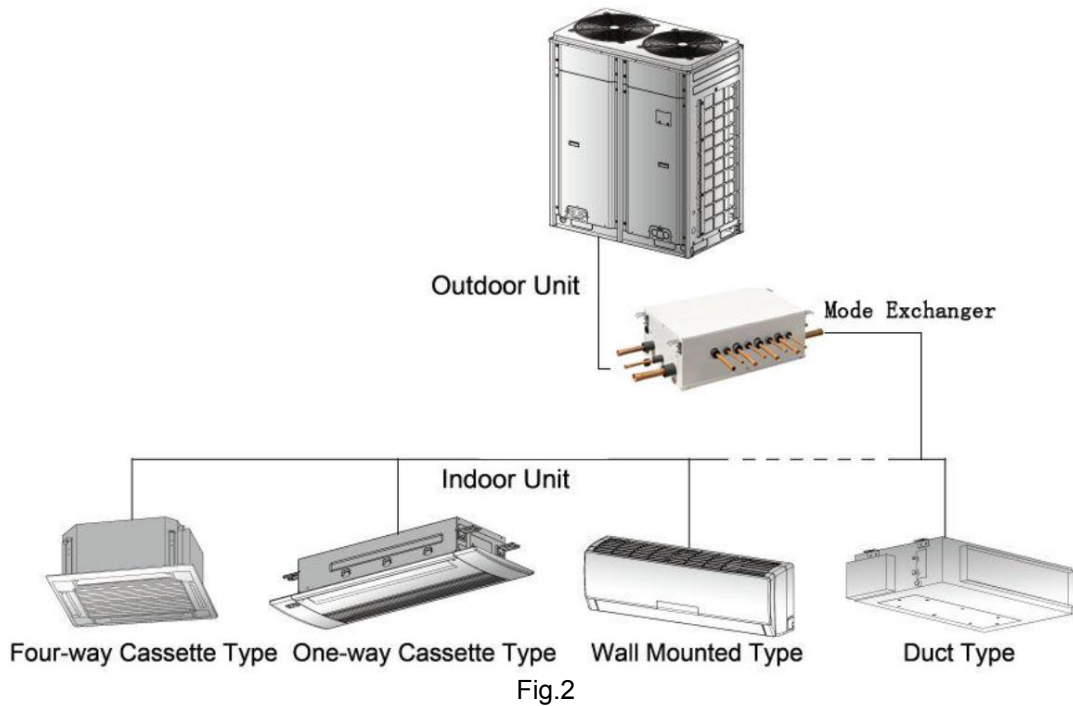

Fig.2 is the combination view of the ODU of Ultra Heat GMV Multi VRF Modular System (heat recovery serial) and the IDU of Multi VRF System. IDU can be cassette type, one-way cassette type, wall-mounted type, duct type, etc. When any one IDU receives operation signal, ODU will start to work according to the capacity; when all IDUs stop, ODU will also stop.

## 2.4 The Range of Production Working Temperature

Cooling operation	Ambient temperature: -10° C(14° F)~52° C(125.6° F)
Heating operation	Ambient temperature: -30° C(-22° F)~24° C(75.2° F)
Heat recovery operation	Ambient temperature: -10° C(14° F)~20° C(68° F)

When the indoor units are all VRF air processor, the unit operating range is as follows:

Cooling operation	Ambient temperature: 16° C(60.8° F)~45° C(113° F)
Heating operation	Ambient temperature: -7° C(19.4° F)~16° C(60.8° F)

**NOTICE!** Out of the working Temperature Range may damage this products and will invalidate the warranty.

Electrify the unit 8 hours before operation. Please switch on for 8 hours before operation. Do not cut off the power when 24 hours short-time halting (to protect the compressor).



### 3 Preparation before Installation

**Note:** The picture is only used for reference and the actual product prevails. Unit: mm (inch).

#### 3.1 Standard Parts

Please use the following standard parts supplied by Gree.

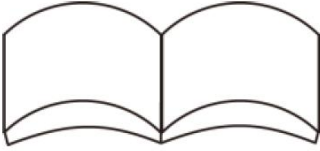
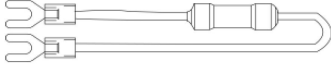
Parts for Outdoor Unit				
Number	Name	Picture	Quantity	Remarks
1	Owner's Manual		1	
2	Wiring (match with resistance)		2	A resistance must be connected to the last mode exchanger D1/D2 connecting with ODU. Another resistance is connected to the last system master ODU G1/G2 when multi-refrigeration systems are connecting with the centralized controller.

#### 3.2 Installation Site

 <b>WARNING</b>
Install the unit at a place where is adequate to withstand the weight of the unit and make sure the unit would not shake or fall off.
Never expose the unit under direct sunshine and rainfall. Install the unit at a place where is against dust, typhoon and earthquake.
Try to keep the unit away from combustible, inflammable and corrosive gas or exhaust gas.
Leave some space for heat exchanging and servicing so as to guarantee unit normal operation.
Keep the indoor and outdoor units close to each other as much as possible so as to decrease the pipe length and bends.
Never allow children to approach to the unit and take measures to prevent children touching the unit.

##### 3.2.1 Space requirement for the surround of outdoor unit

When the unit is surrounded by obstructions in four directions, please keep the distance between the unit top and the top wall at least 3000mm (118-1/8inch) or above. And keep the distance between the unit and the surrounded wall at least 1000mm (39-1/4inch) or above.

- 1) Space dimension for single-module unit

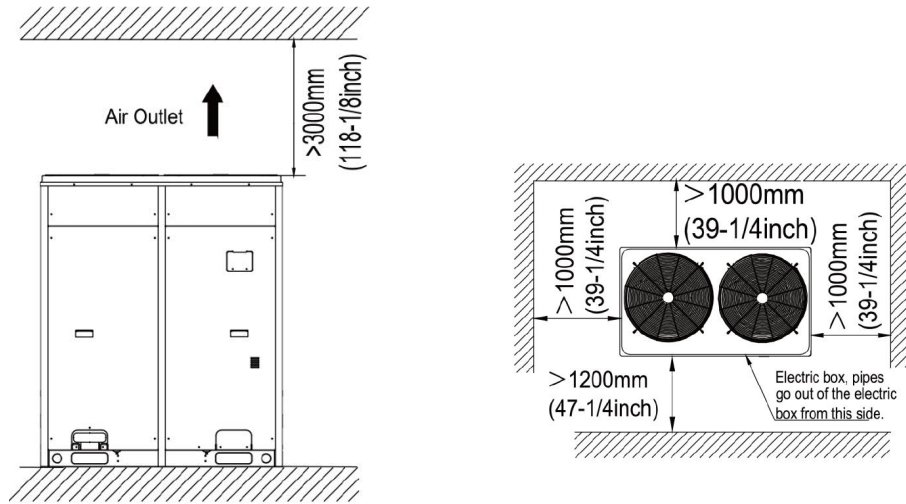

Fig.3

2) Space dimension for dual-module unit

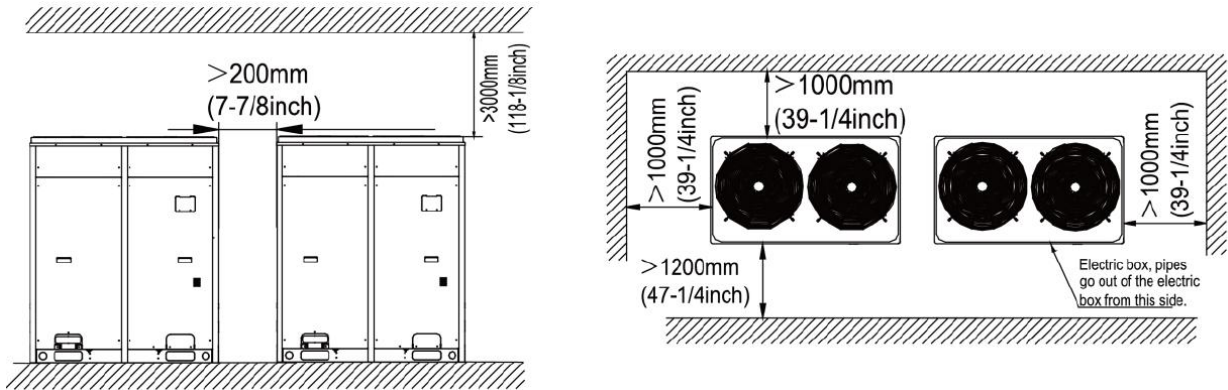

Fig.4

3.2.2 Space requirement for the top of outdoor unit

When the unit is located in a totally open space with no obstructions in four directions, keep the distance between the unit top and wall at least 1500mm (59inch) or above (See Fig.5). When space is limited within 1500mm (59inch) or the unit is not set in an open space, air return pipe is required to be installed in order to keep good ventilation (See Fig.6).

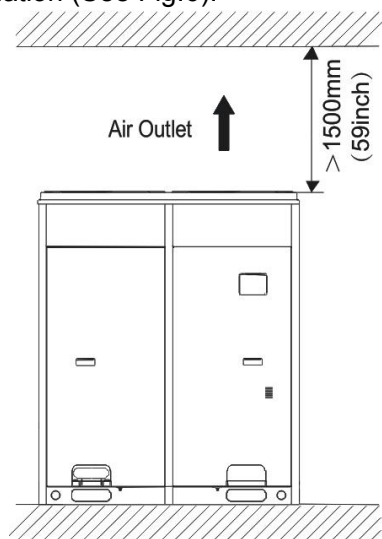

Fig.5

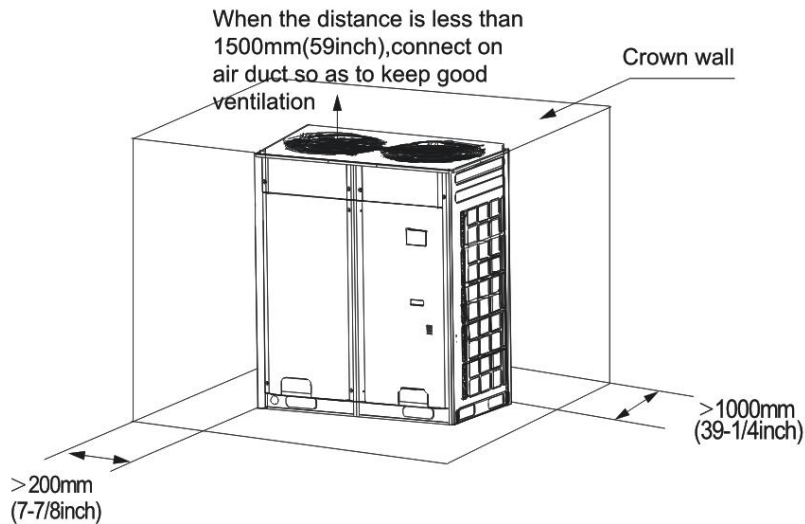

Fig.6

### 3.2.3 Space dimension for multiple-module unit

For keeping good ventilation, make sure there are no obstructions above the unit.

When the unit is located at a half-open space (front and left/right side is open), install the unit as per the same or opposite direction.

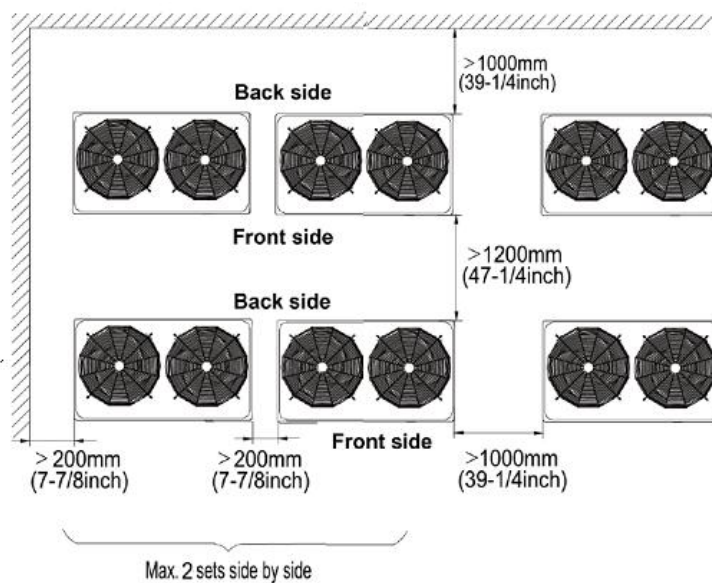
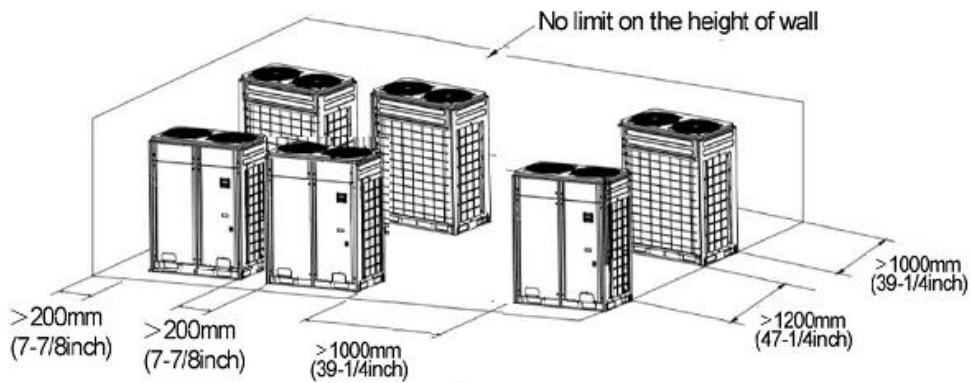

Fig.7

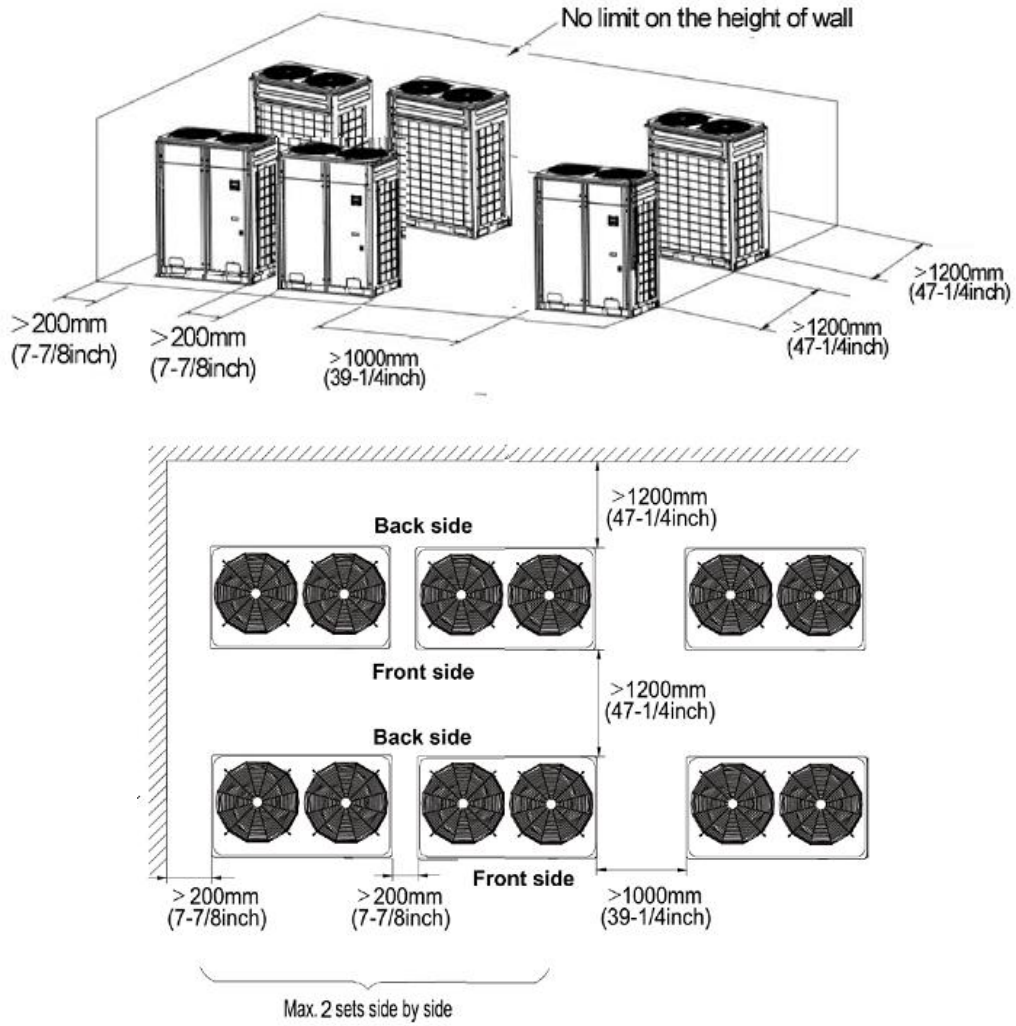

Fig.8

3.2.3 Take seasonal wind into consideration when installing the outdoor unit

1) Anti-monsoon installation requirements for unit not connecting exhaust duct

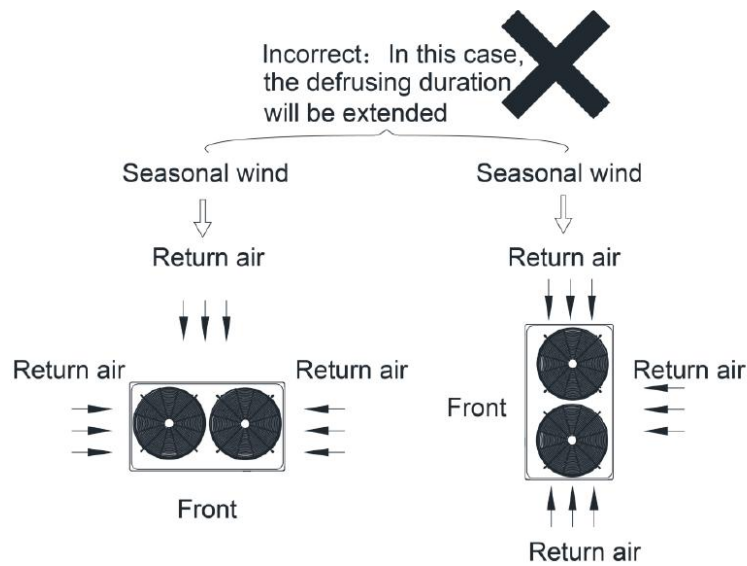

Fig.9



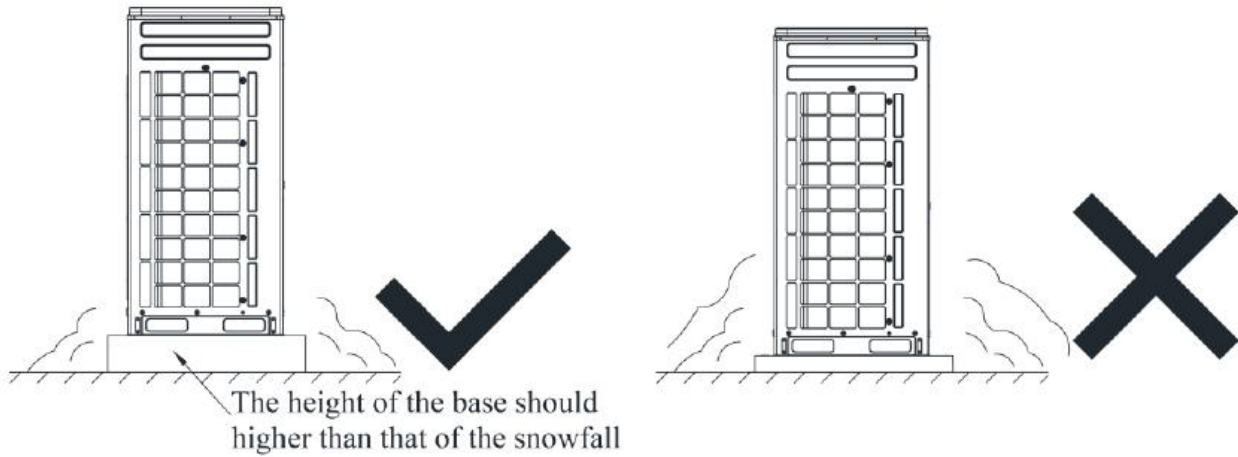

Fig.12

### 3.3 Piping Work Requirements

There should be no fall among outdoor modules. Refer to the table below for piping work requirements.

R410A Refrigeratn System		
Outer diameter (mm/inch)	Wall thickness (mm)	Type
Φ6.35(1/4)	≥0.8	0
Φ9.52(3/8)	≥0.8	0
Φ12.70(1/2)	≥0.8	0
Φ15.9(5/8)	≥1.0	0
Φ19.05(3/4)	≥1.0	1/2H
Φ22.2(7/8)	≥1.2	1/2H
Φ25.40(1/1)	≥1.2	1/2H
Φ28.60(9/8)	≥1.2	1/2H
Φ31.80(5/4)	≥1.3	1/2H
Φ34.90(11/8)	≥1.3	1/2H
Φ38.10(12/8)	≥1.5	1/2H
Φ41.30(13/8)	≥1.5	1/2H
Φ44.5(7/4)	≥1.5	1/2H
Φ51.4(7/4)	≥1.5	1/2H
Φ54.1(17/8)	≥1.5	1/2H

## 4 Installation Instruction

### 4.1 ODU Foundation

The concrete foundation of the ODU must be strong enough. Ensure that the drainage is smooth and that the ground drainage or floor drainage is not affected.

Requirements on the concrete foundation are as follows:

- 1) The concrete foundation must be flat and have enough rigidity and strength to undertake the unit's weight during running. The height of the foundation is 200mm to 300mm, which is determined based on the size of the unit.
- 2) Build a drainage ditch around the foundation to discharge the condensate water.
- 3) If the air conditioner is installed on the roof, check the intensity of the building and take waterproof measures.
- 4) If a u-steel foundation is adopted, the structure must be designed with sufficient rigidity and strength.

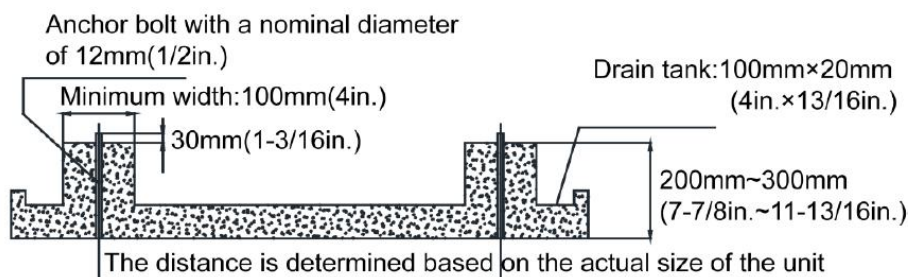

Cement foundation diagram

Fig.13

## 4.2 Physical Dimension of the Outdoor Unit and Mounting Hole

Outline and physical dimension of GMV-VQ72W/A-F(U)、GMV-VQ96W/A-F(U) :

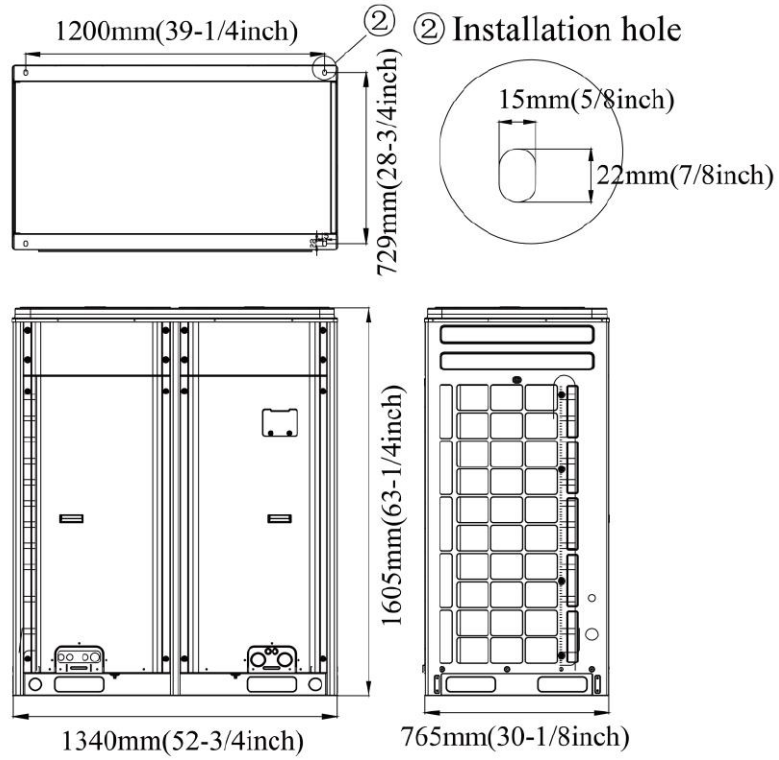

Fig.14



### 4.3 Connection Pipe

#### 4.3.1 Schematic diagram of piping connection

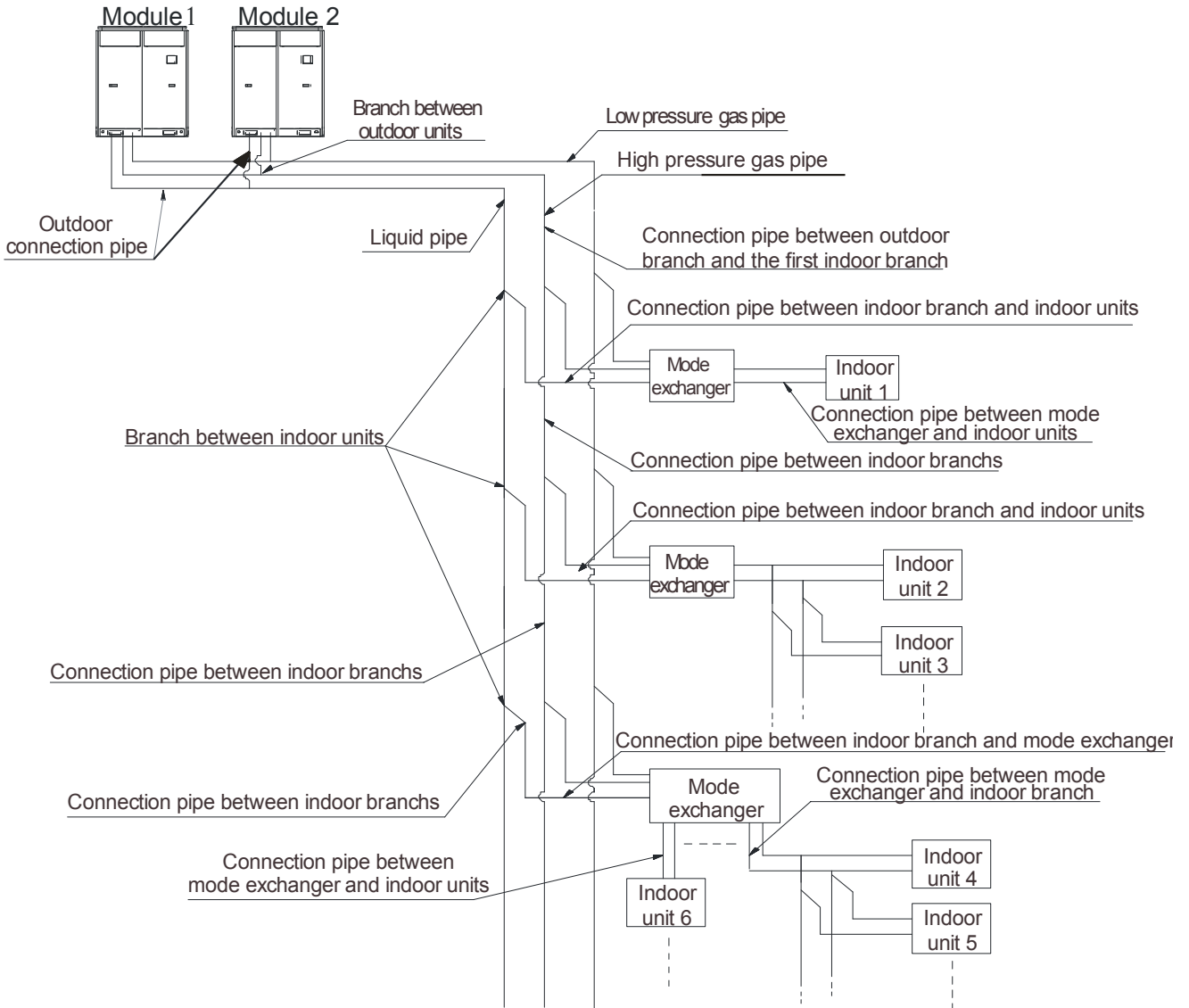

Fig.15

#### 4.3.2 Schematic diagram of piping sequence

GMV-VQ72W/A-F(U)、GMV-VQ96W/A-F(U) :

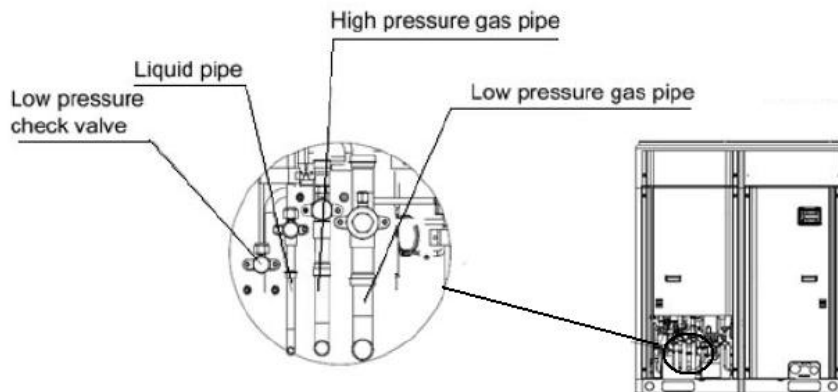

Fig.16

### 4.3.3 Allowable pipe length and drop height among indoor and outdoor units

Y type branch joint is adopted to connect indoor and outdoor units. Connecting method is shown in the figure below.

Remark: Equivalent length of one Y-type manifold is about 0.5m (1-3/4feet).

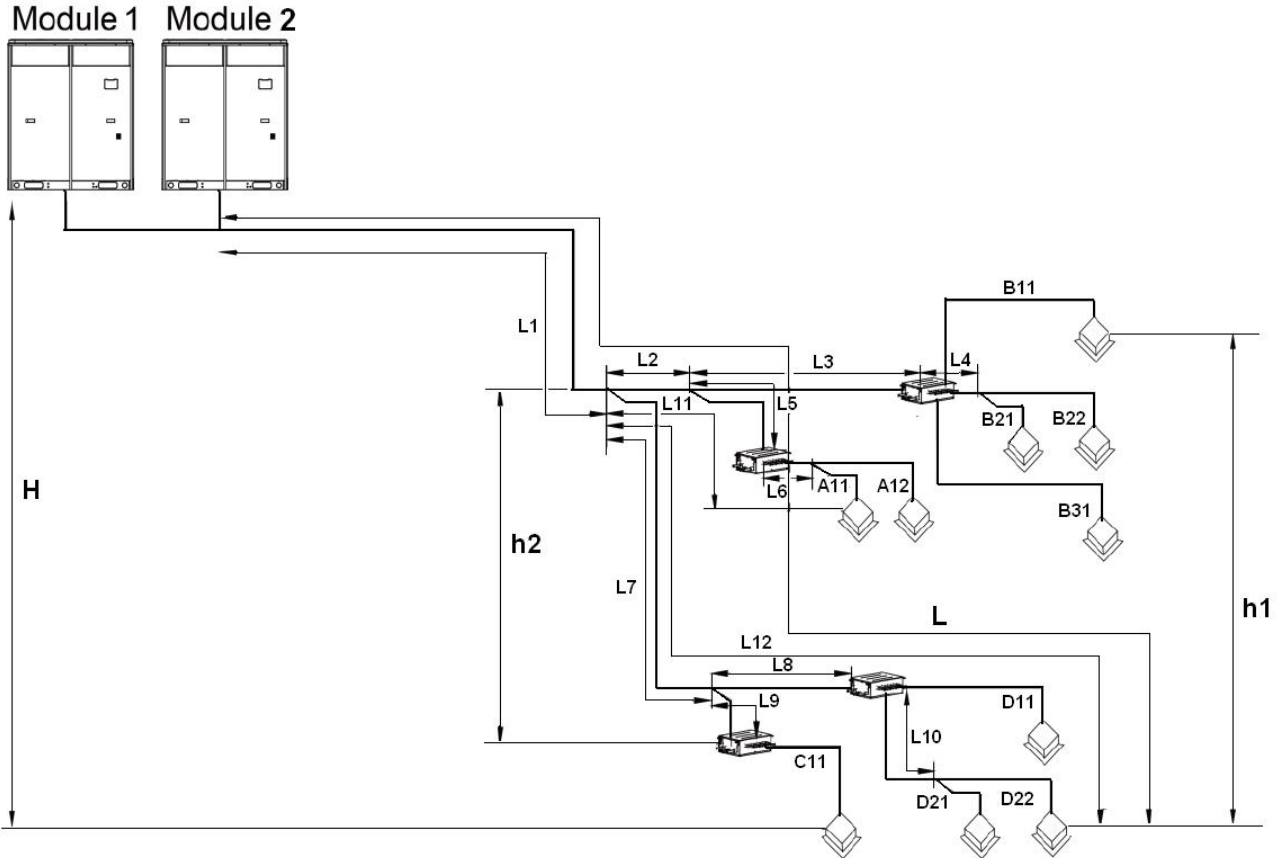

Fig.17

L12: Length from the first branch to the farthest IDU; L11: Length from the first branch to the nearest IDU; Equivalent length of branch of IDU is 0.5m (1-3/4feet).

Equivalent length of mode exchanger depends on the using situation, for example, when using one branch, the length is 1m (39-3/8 inch), when using N branches, the length is N meters.

R410A Refrigerant System		Allowable Value m(feet)	Fitting Pipe
Total length (actual length) of fitting pipe		$\leq 1000(3280-3/4)$	$L1+L2+L3+L4+...+L10+A11+A12+...+D21+D22$
Length of farthest fitting pipe m(feet)	Actual length	$\leq 165(541-1/4)$	L
	Equivalent length	$\leq 190(623-1/4)$	
Difference between the pipe length from the first branch of IDU to the farthest IDU and the pipe length from the first branch of IDU to the nearest IDU		$\leq 40(131-1/4)$	L12-L11
Equivalent length from the first branch to the furthest piping (1)		$\leq 40(131-1/4)$	$L7+L8+L10+D22$
Height difference between outdoor unit and indoor unit	Outdoor unit at upper(2)	$\leq 50(164)$	—
	Outdoor unit at lower(2)	$\leq 40(131)$	—

Height difference between indoor units	≤15(49)	h1
Maximum length of Main pipe(3)	≤90(295-1/4)	L1
From IDU to its nearest branch (4)	≤40(131-1/4)	A11,A12,B21,B22,D21,D22

**Notices:**

(1) Normally, the pipe length from the first branch of IDU to the farthest IDU is 40m (131-1/4feet). Under the following conditions, the length can reach 90m (295-1/4feet).

- 1) Actual length of pipe in total:  $L1+L2x2+L3x2+L4x2+...+L9x2+L10 x2+A11+A12+...+D21+D22 \leq 1000m (3280- 3/4feet)$ .
- 2) Length between each IDU and its nearest branch A11, A12, B11, B21, B22, B31, C11, D11, D21, D22≤40m(131- 1/4feet).
- 3) Difference between the pipe length from the first branch of IDU to the farthest IDU and the pipe length from the first branch of IDU to the nearest IDU:  $L12-L11 \leq 40m (131-1/4feet)$ .

(2) When the outdoor unit is at upper side and height difference is more than 50m, please consult company for the related technical requirement.

(3) When the maximum length of the main pipe from ODU to the first branch of IDU is  $\geq 50m (164 ft)$ , then adjust the pipe size.

Total rated capacity of ODU: C (Btu/h)	Pipe between outdoor unit and the first indoor branch		
	Low pressure gas pipe mm(inch)	Liquid pipe mm(inch)	High pressure gas pipe mm(inch)
GMV-VQ72W/A-F(U)	No need to enlarge pipe size	No need to enlarge pipe size	Φ22.2(7/8)
GMV-VQ96W/A-F(U)	No need to enlarge pipe size	No need to enlarge pipe size	Φ22.2(7/8)
GMV-VQ144WM/A-F(U)	No need to enlarge pipe size	Φ19.05(3/4)	Φ31.8(1-1/4)
GMV-VQ168WM/A-F(U)	No need to enlarge pipe size	Φ19.05(3/4)	Φ31.8(1-1/4)
GMV-VQ192WM/A-F(U)	No need to enlarge pipe size	Φ19.05(3/4)	Φ31.8(1-1/4)

(4) If the length between an IDU and its nearest branch is above 10m (32-4/5feet), then increase the size of the liquid pipe of IDU (only for the pipe size that is ≤6.35mm (1/4inch)).

**4.3.4 Connection pipe among outdoor modules**

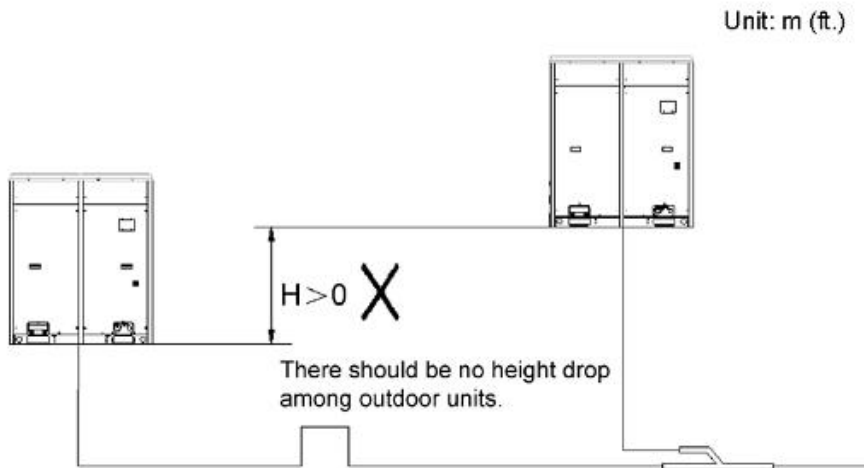

Fig.18

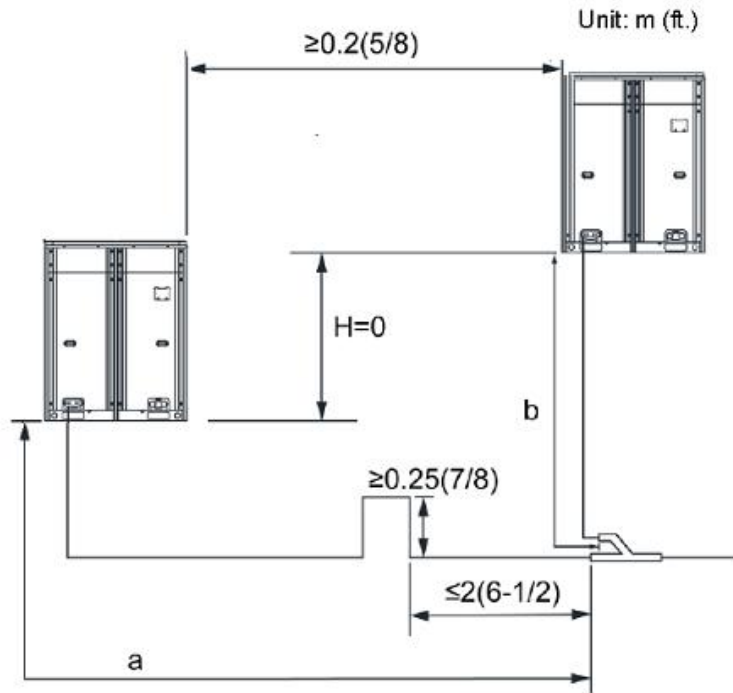

Fig.19

Note: when the distance between outdoor units exceeds 2m (6-1/2 feet), U-type oil trap should be added at low-pressure gas pipe.  $a \leq 10\text{m}$  (32-7/8 feet);  $b \leq 10\text{m}$  (32-7/8 feet).

### 4.3.5 Size requirement for branch pipe and piping

#### 4.3.5.1 Connection sketch map of single-module system

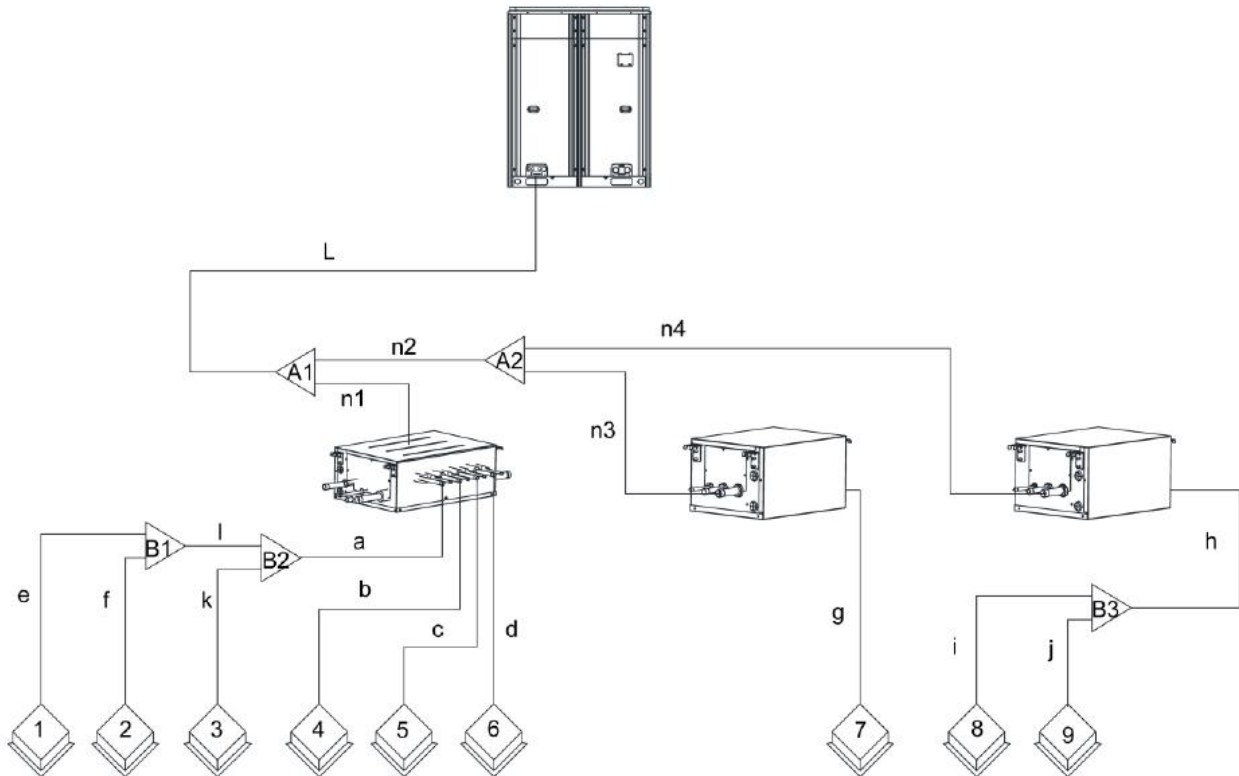

Fig.20

4.3.5.2 Connection sketch map of multi-module system

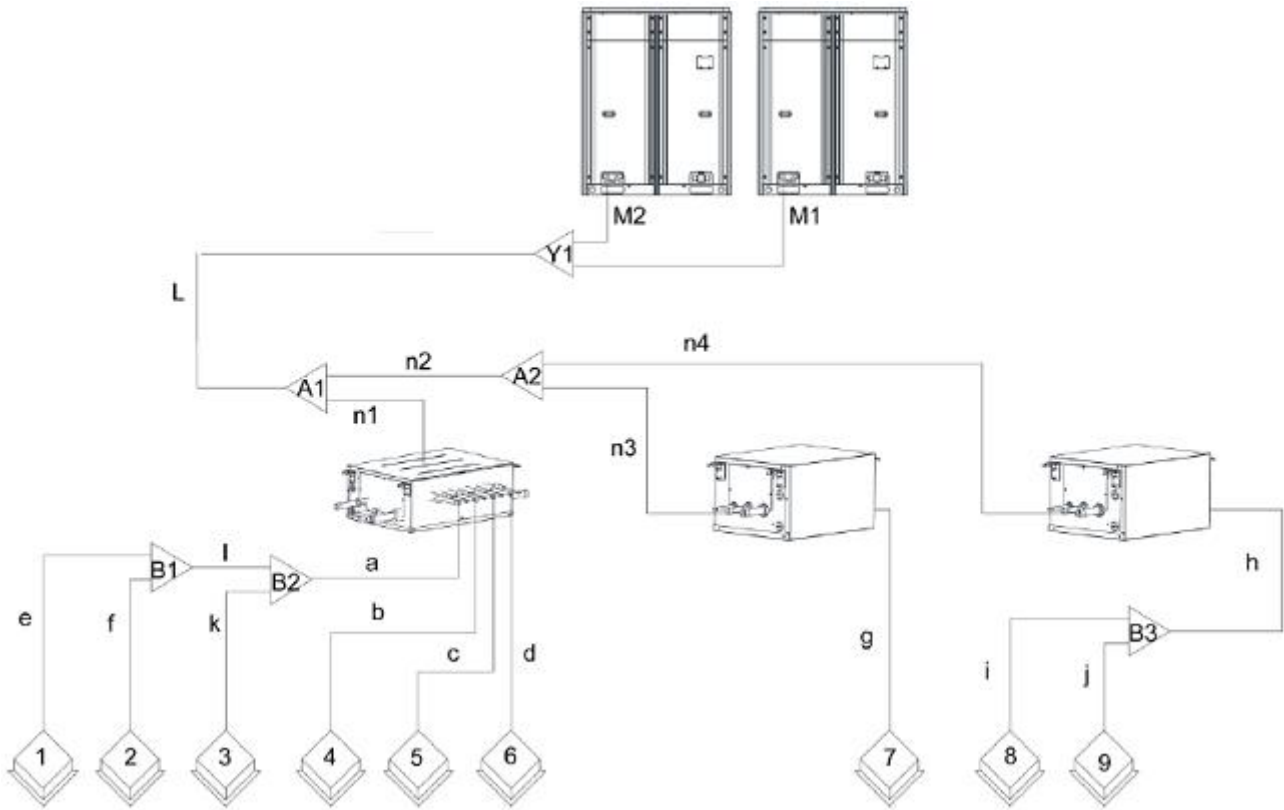

Fig.21

4.3.5.3 Pipe selection between outdoor unit and the first indoor branch (“L”)

For single module, L pipe between the basic outdoor unit and the first indoor branch:

Basic module	Pipe between outdoor unit and the first indoor branch		
	Low pressure gas pipe mm(inch)	Liquid pipe mm(inch)	High pressure gas pipe mm(inch)
GMV-VQ72W/A-F(U)	Φ28.6(1-1/8)	Φ12.7(1/2)	Φ19.05(3/4)
GMV-VQ96W/A-F(U)	Φ28.6(1-1/8)	Φ12.7(1/2)	Φ19.05(3/4)

For multi-module, L pipe between the terminal outdoor branch and the first indoor branch:

Basic module	Pipe between outdoor unit and the first indoor branch		
	Low pressure gas pipe mm(inch)	Liquid pipe mm(inch)	High pressure gas pipe mm(inch)
GMV-VQ144WM/A-F(U)	Φ34.9(1-3/8)	Φ15.9(5/8)	Φ28.6(1-1/8)
GMV-VQ168WM/A-F(U)	Φ34.9(1-3/8)	Φ15.9(5/8)	Φ28.6(1-1/8)
GMV-VQ192WM/A-F(U)	Φ34.9(1-3/8)	Φ15.9(5/8)	Φ28.6(1-1/8)

4.3.5.4 ODU pipe size selection for multi-module system

Pipe size between module and outdoor branch “M1, M2”:

Basic module	Pipe between outdoor unit and the first indoor branch		
	Low pressure gas pipe mm(inch)	Liquid pipe mm(inch)	High pressure gas pipe mm(inch)
GMV-VQ72W/A-F(U)	Φ28.6(1-1/8)	Φ12.7(1/2)	Φ19.05(3/4)

GMV-VQ96W/A-F(U)	Φ28.6(1-1/8)	Φ12.7(1/2)	Φ19.05(3/4)
------------------	--------------	------------	-------------

Selection of branch “Y1” connecting to outdoor modules:

Module's capacity C (Btu/h)	Model
$C \leq 327500$	ML01R
$327500 < C$	ML02R

#### 4.3.5.5 Branch selection of mode exchanger (“A1, A2”)

R410A refrigerant system	Total Capacity of the Downstream Indoor Unit X(Btu/h)	Model
Y-Type Branch Pipe	$X \leq 17100$	FQ01Na/A
	$17100 < X \leq 72000$	FQ02Na/A
	$72000 < X \leq 96000$	FQ03Na/A
	$96000 < X \leq 232000$	FQ05Na/A
	$232000 < X \leq 327500$	FQ05Na/A
	$327500 < X$	FQ06Na/A

#### 4.3.5.6 Pipe size among upstream branches of heat pump mode exchanger (“n1, n2, n3, n4”)

Total rated capacity of downstream indoor units: X(Btu/h)	Size of connection pipe between branches of mode exchanger		
	Low pressure gas pipe mm(inch)	Liquid pipe mm(inch)	High pressure gas pipe mm(inch)
$X \leq 17100$	Φ12.7(1/2)	Φ6.35(1/4)	Φ12.7(1/2)
$17100 < X \leq 48500$	Φ15.9(5/8)	Φ9.52(3/8)	Φ12.7(1/2)
$48500 < X \leq 72000$	Φ19.05(3/4)	Φ9.52(3/8)	Φ15.9(5/8)
$72000 < X \leq 96000$	Φ22.2(7/8)	Φ12.7(1/2)	Φ19.05(3/4)
$96000 < X \leq 120000$	Φ28.6(1-1/8)	Φ12.7(1/2)	Φ22.2(7/8)
$120000 < X \leq 144000$	Φ28.6(1-1/8)	Φ12.7(1/2)	Φ22.2(7/8)
$144000 < X \leq 168000$	Φ34.9(1-3/8)	Φ15.9(5/8)	Φ28.6(1-1/8)
$168000 < X \leq 216000$	Φ34.9(1-3/8)	Φ15.9(5/8)	Φ28.6(1-1/8)
$216000 < X \leq 240000$	Φ34.9(1-3/8)	Φ15.9(5/8)	Φ28.6(1-1/8)
$240000 < X \leq 312000$	Φ34.9(1-3/8)	Φ19.05(3/4)	Φ28.6(1-1/8)
$312000 < X \leq 336000$	Φ34.9(1-3/8)	Φ19.05(3/4)	Φ28.6(1-1/8)
$336000 < X \leq 360000$	Φ41.3(1-5/8)	Φ19.05(3/4)	Φ34.9(1-3/8)

#### 4.3.5.7 Pipe size among downstream branches of mode exchanger (“a, h”)

Total rated capacity of downstream indoor units: X ((Btu/h)	Size of piping between indoor branches	
	Gas pipe mm(inch)	Liquid pipe mm(inch)
$X \leq 9500$	Φ9.52(3/8)	Φ6.35(1/4)
$9500 < X \leq 17100$	Φ12.7(1/2)	Φ6.35(1/4)
$17100 < X \leq 48500$	Φ15.9(5/8)	Φ9.52(3/8)

4.3.5.8 Branch selection of downstream indoor unit of mode exchanger (“B1, B2, B3”)

R410A refrigerant system	Total rated capacity of downstream indoor units: X(Btu/h)	Model
Y-type branch	X≤48500	FQ01A/A

4.3.5.9 Pipe size between mode exchanger and downstream indoor unit (“b, c, d, g”)

Total rated capacity of downstream indoor units: X (Btu/h)	Piping size between indoor branches	
	Gas pipe mm(inch)	Liquid pipe mm(inch)
X≤9500	Φ9.52(3/8)	Φ6.35(1/4)
9500<X≤17100	Φ12.7(1/2)	Φ6.35(1/4)
17100<X≤48500	Φ15.9(5/8)	Φ9.52(3/8)

4.3.5.10 Pipe size between indoor branch and indoor unit (“e, f, i, j, k”)

Rated capacity of indoor units: X ((Btu/h)	Size of connection pipe between indoor branch and indoor unit	
	Gas pipe mm(inch)	Liquid pipe mm(inch)
X≤9500	Φ9.52(3/8)	Φ6.35(1/4)
9500<X≤17100	Φ12.7(1/2)	Φ6.35(1/4)
17100<X≤48500	Φ15.9(5/8)	Φ9.52(3/8)

4.3.5.11 Pipe size between indoor branches (“l”)

Rated capacity of indoor units: X ((Btu/h)	Size of connection pipe between indoor branch and indoor unit	
	Gas pipe mm(inch)	Liquid pipe mm(inch)
X≤9500	Φ9.52(3/8)	Φ6.35(1/4)
9500<X≤17100	Φ12.7(1/2)	Φ6.35(1/4)
17100<X≤48500	Φ15.9(5/8)	Φ9.52(3/8)

4.3.6 Connection method when capacity of indoor unit exceeds 48500 Btu/h

When connecting to the indoor unit with capacity of over 48500 Btu/h, it is not allowed to connect with only one branch; it must use two branches controlled by the same main board for parallel connection.

Parallel connection	Indoor unit communication connection for mode exchanger	Remarks
Indoor unit No.1 and No.2	“1D1 1D2”	Parallel connection can be conducted only as the combination of this table, it is not allowed to otherwise connect. Note that after the connection, manually set the SA2 dial code of corresponding main board, and dial the code in the first place to number end.
Indoor unit No.3 and No.4	“3D1 3D2”	
Indoor unit No.5 and No.6	“5D1 5D2”	
Indoor unit No.7 and No.8	“7D1 7D2”	

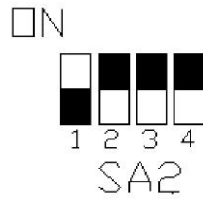

Fig.22

Connecting method is shown as in the Fig.23.

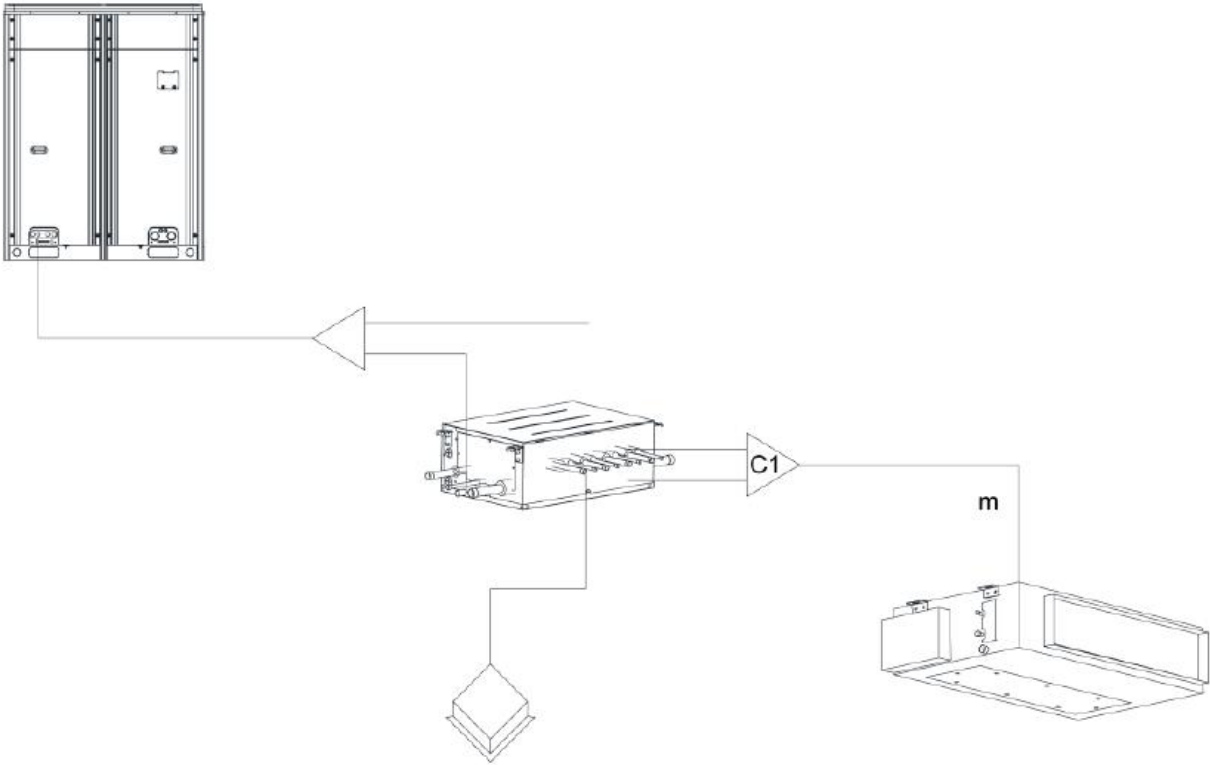

Fig.23

4.3.6.1 Branch selection of indoor unit of mode exchanger (“C1”)

R410A refrigerant system	Total rated capacity of downstream indoor units: X(Btu/h)	Model
Y-type branch	48500<X≤96000	FQ01B/A

4.3.6.2 Pipe size between mode exchanger and downstream and indoor unit (“m”)

Rated capacity of indoor units: X ((Btu/h)	Size of connection pipe between indoor branch and indoor unit	
	Gas pipe mm(inch)	Liquid pipe mm(inch)
48500<X≤72000	Φ19.05(3/4)	Φ9.52(3/8)
72000<X≤96000	Φ22.2(7/8)	Φ9.52(3/8)

4.4 Installation of the Connection Pipe

**Notice:** before welding the pipeline sealing cap, please make sure there's no refrigerant in pipeline. If welding it directly, it may cause unnecessary property damage or personal injury.

4.4.1 Precautions when installing the connection pipe



(1) Conform to the following principles during piping connection: Connection pipeline should be as short as possible. The height difference between indoor and outdoor units should be as short as possible. Keep number of bends as little as possible. The radius of curvature should be as large as possible.

(2) Weld the connection pipes between indoor and outdoor unit. Please strictly conform to the requirements for welding process. Rosin joints and pin holes are not allowable.

(3) When laying the pipes, be careful not to deform them. The radius of bending parts should be more than 200mm (7-7/8inch). The pipes cannot be repeatedly bent or stretched; otherwise the material will get harden. Do not bend or stretch the pipe over three times at the same position.

(4) Please use a torque wrench to connect union nut on the indoor unit. See Fig.24.

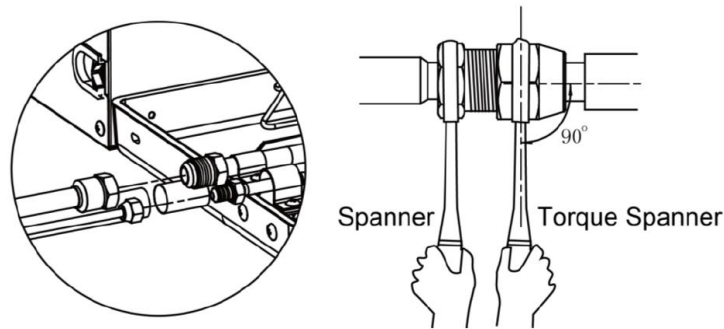

Fig.24

- 1) Align the expansion end of copper pipe with the center of threaded joint. Tighten the flare nuts with your hands.
- 2) Tighten the flare nuts with torque wrench until you hear "click" sound.
- 3) Use sponge to wrap the connecting pipe and joints without thermal insulation and tie it up with plastic tape.
- 4) A mounting support for the connection pipe is required.
- 5) The curvature degree of connection pipe should not be small, otherwise the pipe might crack. Installation personnel should use tube bender when bending the pipe.
- 6) Don't forcibly stretch the pipe joint, otherwise indoor capillary or other pipes might be damaged and lead to refrigerant leakage.

#### 4.4.2 Y-type manifold

(1) Y-type manifold

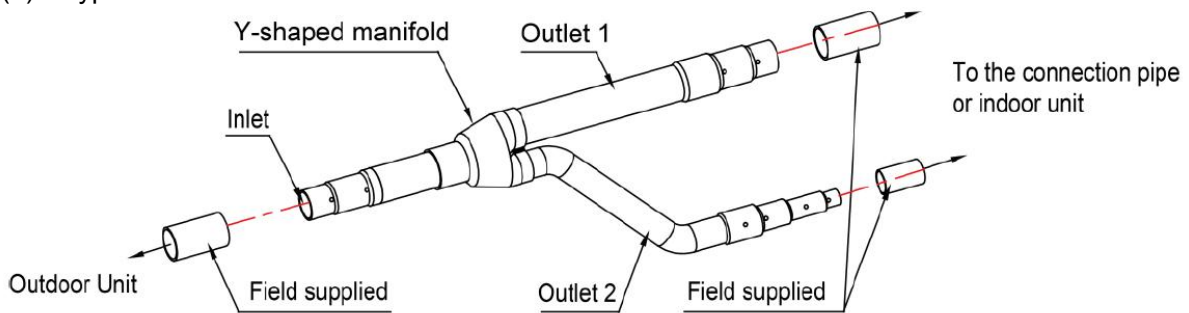

Fig.25

(2) Y-type manifold has several pipe sections with different pipe size, which facilitates to match with various copper pipe. Use pipe cutter to cut in the middle of the pipe section with different pipe size and

deburr as well. See Fig.15.

(3) Y-type manifold must be installed vertically or horizontally.

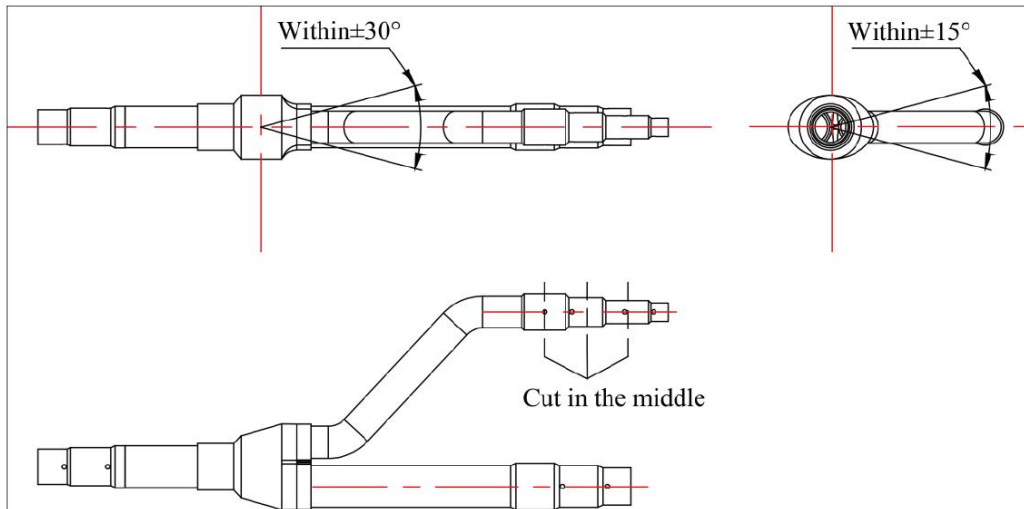

Fig.26

Y-type manifold	Total capacity of downstream indoor unit(s) C (Btu/h)	Model
	$C \leq 68000$	FQ01A/A
	$68000 < C \leq 102000$	FQ01B/A
	$102000 < C \leq 239000$	FQ02/A
	$239000 < C$	FQ03/A

(4) Manifold is isolated by insulating material that can bear 120° C(248 °F) or higher temperature. Manifold attached foam cannot be taken as insulating material.

#### 4.4.3 Thermal insulation for pipeline

(1) For multi VRF system, every copper pipe should be labeled so as to avoid misconnection.

(2) Manifolds can be laid in the following ways:

The length of a straight pipe between two manifolds is 500mm (19-11/16inch) at least. And the length of a straight pipe before main pipe port of the manifold cannot be less than 500mm (19-11/16inch). The length of a straight pipe between the branch of the manifold and IDU cannot be less than 500mm (19-11/16inch).

Unit:mm (in.)

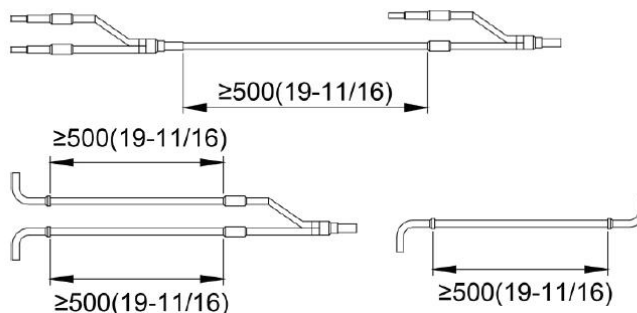

Fig.27

- (3) There must be three fixing point for both horizontal and vertical installation of Y-type manifold.
- Fixing point 1: 100mm (4in.) on the main inlet manifold from the welding point.
- Fixing point 2: 200mm (7-7/8in.) on the main branched manifold from the welding point.
- Fixing point 3: 250mm(9-5/6in.) on the branched pipe from the welding point.

Unit: mm (in.)

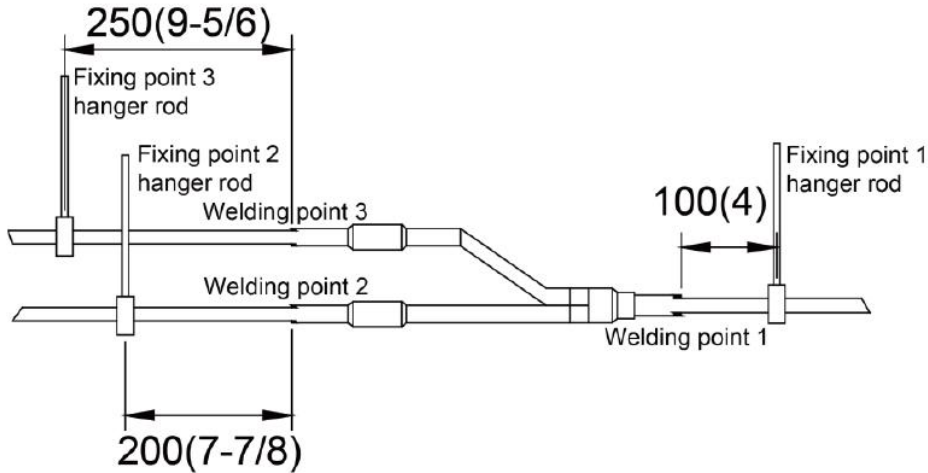

Fig.28

(4) Thermal insulation for pipeline

- 1) To avoid condensate or water leakage on connecting pipe, the gas pipe and liquid pipe must be wrapped with thermal insulating material and adhesive pipe for insulation from the air.
- 2) For heat pump unit, liquid pipe should bear 70° C(158°F) or above, and gas pipe should bear 120° C(248°F) or above. For cooling only unit, both liquid pipe and gas pipe should bear 70° C(158°F) or above. Example: Polyethylene foam can bear 120° C(248°F) above and foaming polyethylene can bear 100° C(212°F) above.
- 3) Joints at indoor and outdoor units should be wrapped with insulating material and leave no clearance between pipe and wall.

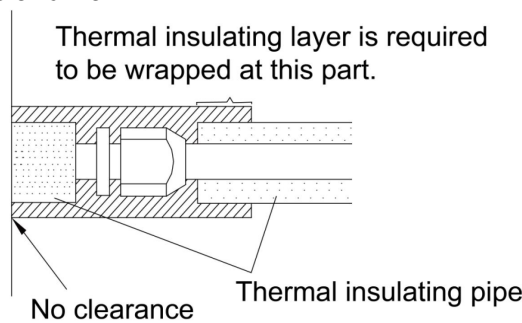

Fig.29

- 4) Manifold attached foam cannot be taken as insulating material.
- 5) When wrapping the tape, the later circle should cover half of the former one. Don't wrap the tape so tightly, otherwise the insulation effect will be weakened.
- 6) After wrapping the pipe, adopt sealing material to completely fill the hole so as to prevent wind and rain from entering the room.

4.4.4 Support and protection for pipeline

(1) Support should be made for hanging connection pipe. Distance between each support cannot be over 1m (39-3/8inch).

(2) Protection towards accidental damage should be made for outdoor pipeline. If the pipeline exceeds 1m (39-3/8inch), a pinch board should be added for protection.

## 4.5 Air Purging and Refrigerant Charge

### 4.5.1 Air purging

(1) Confirm outdoor liquid and gas valves are closed. Air purging from the nozzle located on liquid and gas valves by vacuum pump.

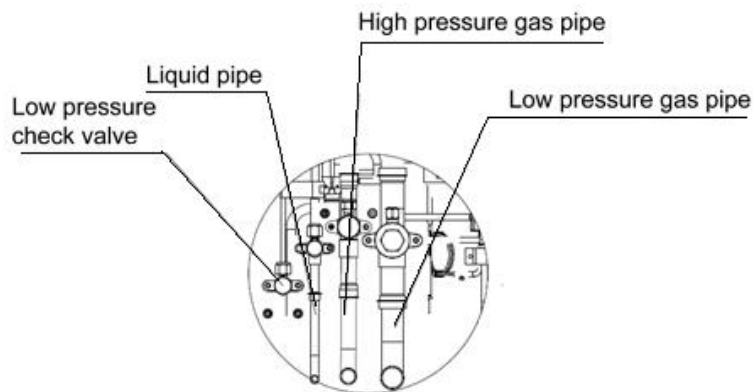

Fig.30

(2) Because air extraction from outdoor unit's liquid valve, high pressure gas valve and low pressure gas valve must be performed simultaneously, 2 sets of vacuum pump must be used at the same time to guarantee the required vacuum degree.

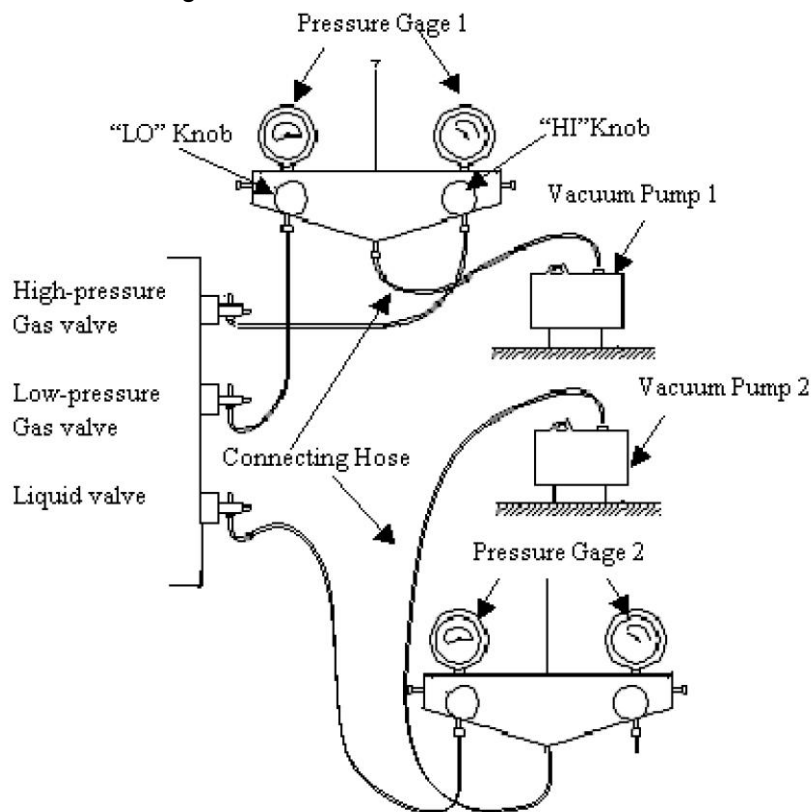

Fig.31

### 4.5.2 Additional refrigerant charging

Outdoor unit has been charged refrigerant before delivery.

If the pipeline is longer than 1m (39-3/8inch), please refer to the following table for charging amount of refrigerant. (Liquid pipe prevails)

Total refrigerant charging amount R= Pipeline charging amount A +  $\Sigma$ charging amount B of every module

(1) Pipeline charging amount

Added refrigerant quantity A for piping = Added refrigerant quantity A1 for liquid piping + Added refrigerant quantity A2 for high pressure gas piping

Added refrigerant quantity A1 for liquid piping =  $\Sigma$ Liquid pipe length  $\times$  Added refrigerant quantity for each meter (inch) of liquid pipe

	Diameter of liquid pipe mm(inch)							
	28.6(1-1/8)	25.4(1)	22.2(7/8)	19.05(3/4)	15.9(5/8)	12.7(1/2)	9.52(3/8)	6.35(1/4)
kg/m	0.680	0.520	0.350	0.250	0.170	0.110	0.054	0.022
OZ/inch	0.61	0.47	0.31	0.22	0.15	0.10	0.05	0.02

Added refrigerant quantity A2 for high pressure gas piping =  $\Sigma$ high pressure gas pipe length  $\times$  Added refrigerant quantity for each meter (inch) of high pressure gas pipe

	Diameter of high pressure gas pipe mm(inch)						
	28.6(1-1/8)	25.4(1)	22.2(7/8)	19.05(3/4)	15.9(5/8)	12.7(1/2)	
kg/m	0.054	0.046	0.032	0.024	0.017	0.009	
OZ/inch	0.048	0.041	0.029	0.022	0.015	0.008	

Note: high pressure gas pipe lengths means all the lengths between ODU and mode exchangers.

(2)  $\Sigma$ Refrigerant charging amount B of every module

Refrigerant charging amount B of every module kg(lb)		Rated Capacity(1000Btu/h)	
IDU/ODU rated capacity collocation ratio C	Quantity of included IDUs(N)	72	96
50% $\leq$ C $\leq$ 90%	N<4	0	0
	N $\geq$ 4	0.5(1.1)	1(2.2)
90%<C $\leq$ 105%	N<4	0	0.5(1.1)
	8>N $\geq$ 4	0.5(1.1)	1.5(3.3)
	N $\geq$ 8	2(4.4)	3(6.6)
105%<C $\leq$ 135%	N<4	0.5(1.1)	1(2.2)
	8>N $\geq$ 4	2.5(5.5)	3.5(7.7)
	N $\geq$ 8	4(8.8)	5(11.0)

For example 1:

The OUD is GMV-VQ192WM/A-F(U) including GMV-VQ96W/A-F(U) and GMV-VQ96W/A-F(U). The IDUs are made up of 10 sets of GMV-ND18PHS/A-T(U).

IDU/ODU rated capacity collocation ratio  $C=18 \times 10 / 192 = 94\%$ . The quantity of included IDUs is more than 8 sets. Please refer to the above table.

Refrigerant charging amount B for GMV-VQ96W/A-F(U) module is 3kg (6.6 lbs).

Refrigerant charging amount B for GMV-VQ96W/A-F(U) module is 3kg (6.6 lbs).

Suppose the Pipeline charging amount A = Added refrigerant quantity A1 for liquid piping + Added refrigerant quantity A2 for high pressure gas piping = 25kg (55.1 lbs)

Total refrigerant charging amount  $R=25+3+3=31\text{kg}$  (55.1+6.6+6.6=68.3 lbs).

For example 2:

The OUD is GMV-VQ72W/A-F(U). The IDUs are made up of 1 set of GMV-NDX72P/A-T(U).

IDU/ODU rated capacity collocation ratio  $C=0/72=0\%$ . Refrigerant charging amount B for GMV-VQ72W/A-F(U) module is 0kg (0 lbs).

Suppose the Pipeline charging amount A = Added refrigerant quantity A1 for liquid piping + Added refrigerant quantity A2 for high pressure gas piping = 25kg (55.1 lbs)

Total refrigerant charging amount  $R=25+0=25\text{kg}$  (55.1+0=55.1 lbs).

After confirming that there is no leakage from the system, charge additional R410A with specified amount to the unit through the filling opening of the liquid pipe valve of the outdoor unit when the compressor is not in operation. If required additional refrigerant cannot be quickly filled for increase of pressure in the pipe, set the unit at cooling startup and then fill the refrigerant from gas valve of outdoor unit. If ambient temperature is low, the unit can't be set to cooling mode but heating mode.

#### 4.5.3 Precautions on refrigerant leakage

Personnel related to air conditioning engineering design and installation operators must abide by the safety requirement for preventing refrigerant leakage specified in local laws and regulations. If such safety requirement is unavailable in local documents, the design and operation must be implemented based on the following principles:

1) Ultra Heat GMV series VRF units adopt the R410A refrigerant, which is nonflammable and nontoxic. However, the space for refrigerant leakage must be sufficient to ensure that the refrigerant concentration does not exceed that specified in the safety requirement; otherwise, people involved can be stifled by the refrigerant. For example, the maximum allowed concentration level of refrigerant to a humanly space for R410A according to the appropriate European Standard is limited to  $0.44\text{kg}/\text{m}^3$ .

The maximum refrigerant charge and maximum refrigerant concentration in the system are calculated directly based on the size of the air conditioning space. The unit of refrigerant concentration is  $1\text{ kg}/\text{m}^3$  or  $1\text{ lb}/\text{m}^3$ .

##### **Method for calculating the maximum concentration of refrigerant:**

(1) Calculate the refrigerant charge quantity of each system.

Charge quantity of an ODU upon delivery (for the system consisting of multiple modules in parallel,

the accumulative charge quantity of modules upon delivery is used) + Onsite charge quantity = Total refrigerant charge quantity in the system (kg)

(2) Calculate the volume of maximum air conditioning space (m³).

Volume of air conditioning space (m³) = Length x Width x Height

Note: The length, width and height here refer to the effective length, width and height of the indoor space.

(3) Calculate the maximum refrigerant concentration of the refrigeration system.

$$\frac{\text{Total refrigerant quantity of the system}}{\text{Minimum volume of air conditioning space}} \leq \text{Maximum supported concentration}$$

**Note:** If the maximum supported refrigerant concentration is not available in relevant local standard, use 0.3kg /m³ (0.66lbs/m³) as the maximum supported refrigerant concentration.

2) If the maximum refrigerant concentration exceeds the allowed threshold, the refrigeration system must be redesigned. In this case, separate the refrigeration system into multiple small-capacity refrigeration systems, or add corresponding ventilation measures or alarming display.

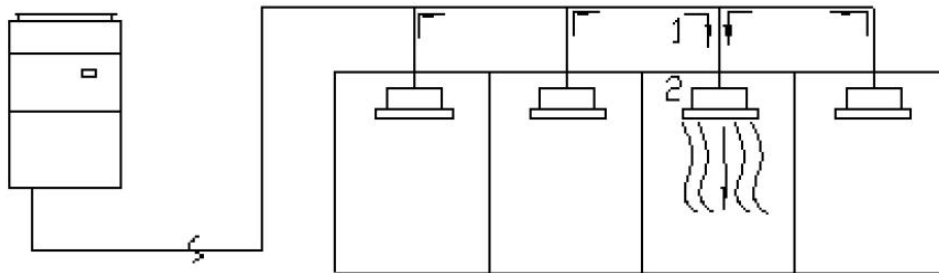



Fig.32

(1) Flow direction of refrigerant leakage.

(2) Room for refrigerant leakage. Since the concentration of refrigerant is greater than that of air, pay attention to the spaces where the refrigerant may residue, for example, the basement.

## 4.6 Electric Wiring

### 4.6.1 Wiring precautions

 <b>WARNING</b>
(1) Wiring should conform to national rules. All the parts, materials, electric work should be in accordance with local codes.
(2) Rated voltage and exclusive power supply should be used.
(3) Power cord should be fixed soundly and reliable. Never forcibly pull the power cord.
(4) Wire size of power cord should be large enough. The damaged power cord and connecting wire should be replaced by exclusive cable.
(5) All the electrical work should be performed by professional personnel as per local law, regulation and this manual.

(6) Connect the unit to the special earthing device and make sure the unit is earthed soundly.

(7) Air switch and circuit breaker is required to be set. Air switch should have both magnetic trip and thermal trip functions so as to protect the unit when short-circuit and overload happens. D-type breaker is advised to be used.

(8) Wiring diagram attached on the unit is prevailed.

#### 4.6.2 Wiring of power cord

Every unit should have corresponding short-circuit and overload protection. And also a main switch is required to control power supply or disconnection.

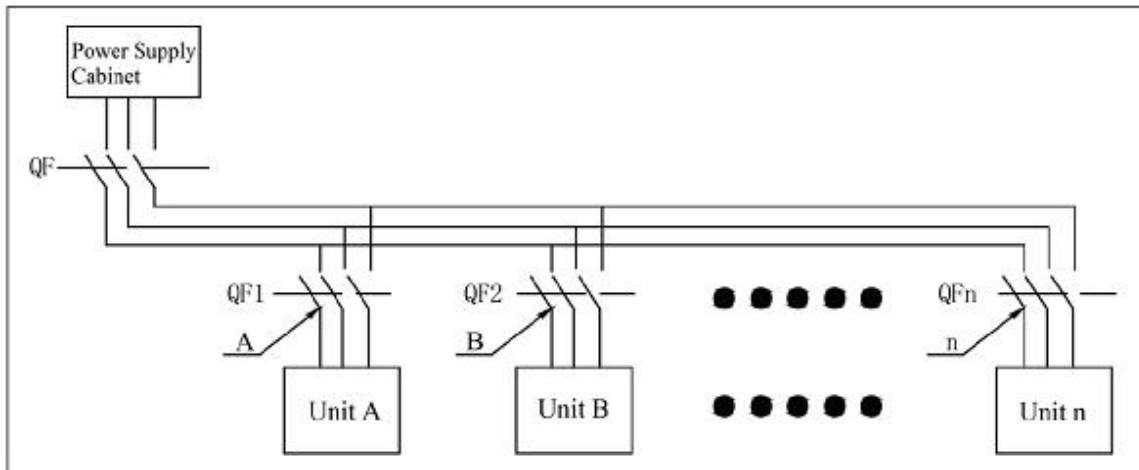

Fig.33

Outdoor Unit:

Outdoor units	Power Supply	Fuse Capacity	Minimum Circuit Ampacity	Maximum Overcurrent Protection
	V/ Ph /Hz	A	A	A
GMV-VQ72W/A-F(U)	208V/230V 3~ 60Hz	50	40	50
GMV-VQ96W/A-F(U)	208V/230V 3~ 60Hz	60	45	60
GMV-VQ144WM/A-F(U)	208V/230V 3~ 60Hz	50+50	40+40	50+50
GMV-VQ168WM/A-F(U)	208V/230V 3~ 60Hz	50+60	40+45	50+60
GMV-VQ192WM/A-F(U)	208V/230V 3~ 60Hz	60+60	45+45	60+60



(1) Specification of circuit breaker and power cord is selected on the basis of unit's maximum power (max. current).

(2) Specification of power cord is based on the working condition where ambient temperature is 40 °C (104 °F) and multi-core cable with copper conductor(working temperature is 90 °C (194 °F)), e.g. power cable with YJV cross-linked copper, insulated PE and PVC sheath) is lying on the surface of slot. If working condition is different, please adjust the specification according to national standard.

(3) Copper-core cable must be used.

(4) The above sectional area is suitable for a maximum distance of 15m (49-1/5feet). If it's over 15m (49-1/5feet), sectional area must be expanded to prevent overload current from burning the wire or causing fire hazard.

(5) Specification of circuit breaker is based on the working condition where the ambient temperature of circuit breaker is 40°C(104°F). If working condition is different, please adjust the specification according to national standard.



- (6) The air switch should include magnetic trip function and thermal trip function so that system can be protected from short circuit and overload.
- (7) An all-pole disconnection switch having a contact separation of at least 3mm (1/8inch) in all poles should be connected in fixed wiring.

### 4.6.3 Connection of power cord

 <b>WARNING</b>
(1) Before obtaining access to terminals, all supply circuits must be disconnected.
(2) If units are type I electrical appliances, they must be reliably grounded.
(3) Ground resistance must be in accord with requirements of local standard.
(4) The green-yellow wire within units are ground wire. Do not use it for other purposes. Nor should it be cut off or secured by tapping screws. Otherwise, it may cause electric shock.
(5) Power supply at user side must have reliable ground terminal. Do not connect ground wire to the following places: <ul style="list-style-type: none"><li>1) Water pipe.</li><li>2) Gas pipe.</li><li>3) Drainage pipe.</li><li>4) Other places that are considered by professionals as unreliable.</li></ul>
(6) Power cord and communication wire should be separated, with a distance of more than 20cm (7-7/8inch). Otherwise, system's communication may not work well.

Steps and graphic of power cord and communication cord connection:

- (1) Knock off the cross-through opening that's used for leading the external power cord, with the cross-through rubber ring on the opening. Then lead the cable through the opening. Connect L1, L2, L3 of power cord and ground wire separately to the positions on wiring board (for power supply) that are marked with L1, L2, L3 and the ground screw nearby.  
Knock off the cross-through opening that's used for leading the external communication cord, with the cross-through rubber ring on the opening. Then lead the cable through the opening. Connect D1, D2, G1, G2 of communication cord separately to the positions on wiring board that are marked with D1, D2, G1, G2.
- (2) Use cable ties to tie the cable securely.
- (3) Use cable ties to tie the rubber rings securely.
- (4) Lead the power cord as instructed in the graphic below:

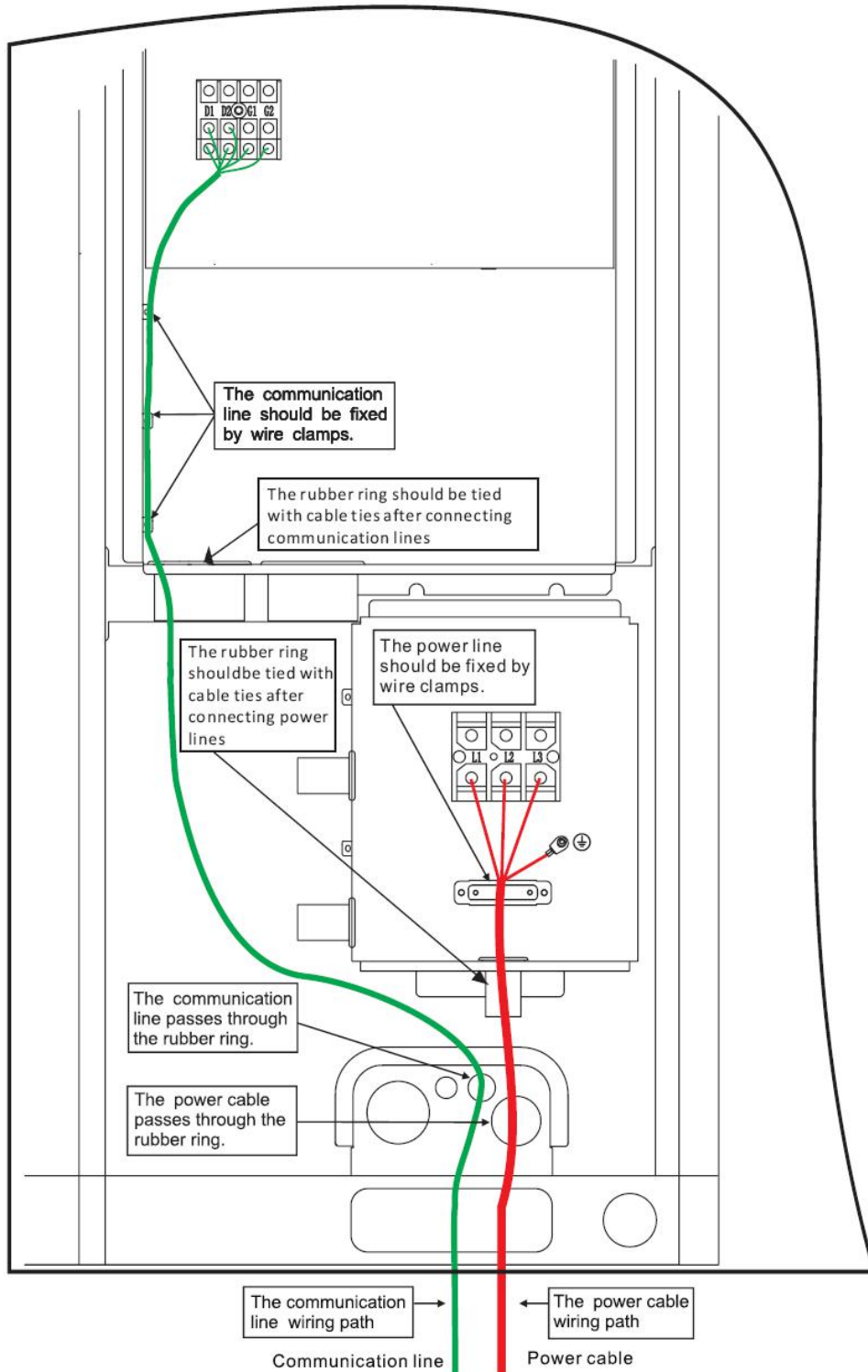

Fig. 34

## 4.7 System Communication

### 4.7.1 Communication system

- (1) Communication among outdoor basic modules.
- (2) Communication between ODU and IDU.
- (3) Communication among IDUs.

- (4) Communication between IDU and wired controller.
- (5) Connection between IDU and light board receiver.
- (6) Communication between different refrigeration systems.
- (7) Graphics of general communication connection.

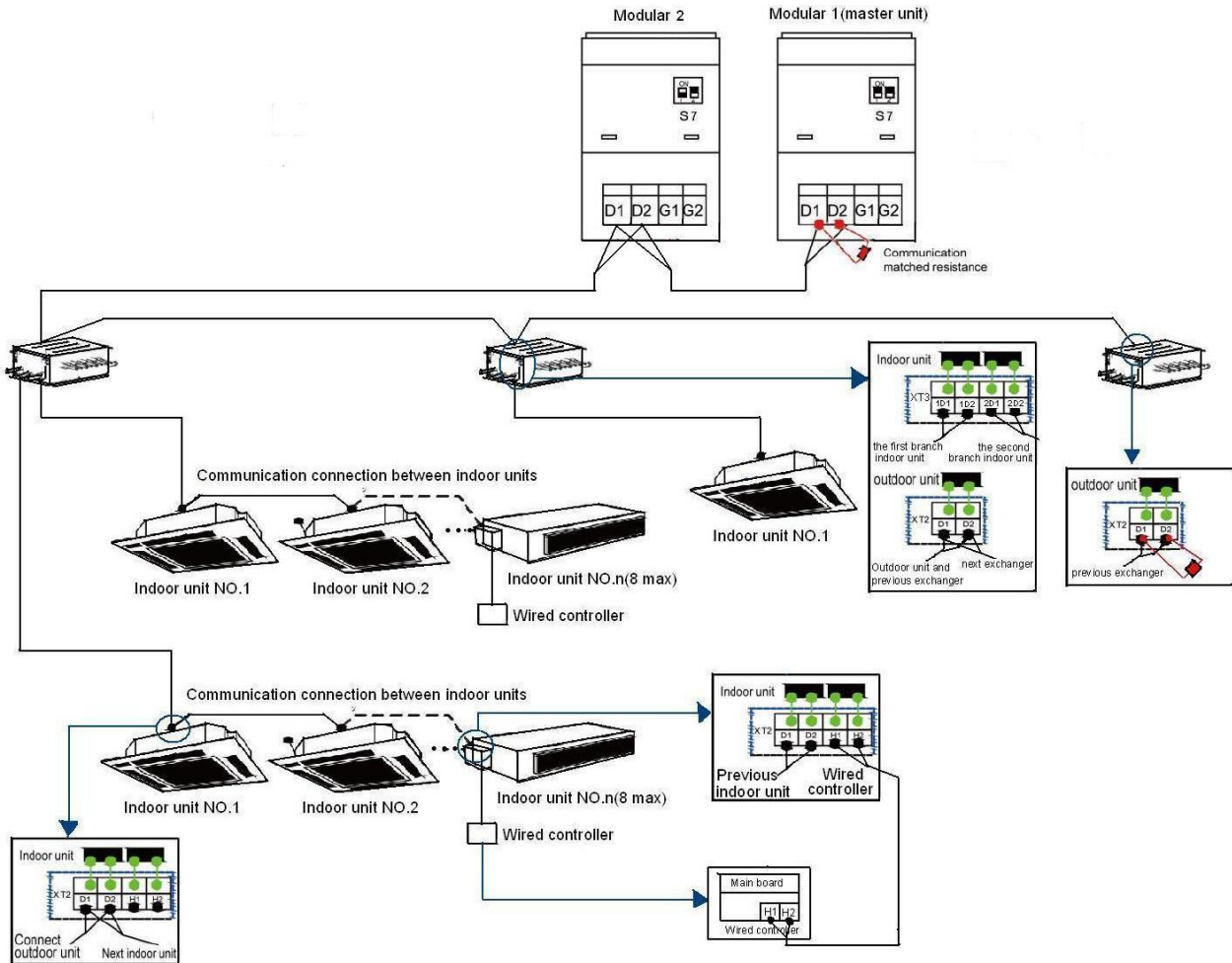

Fig.35

#### 4.7.2 Communication mode of Ultra Heat GMV Multi VRF units

CAN bus is taken for communication between IDU and ODU and communication among IDUS.

#### 4.7.3 Selection and connection mode of communication line

##### 4.7.3.1 Select communication material

**NOTICE!** If air conditioners are installed at places where there's strong electromagnetic interference, the communication wire of IDU and wired controller must use shielded wire and the communication wire between IDU and IDU/ODU must use shielded twisted pair.

(1) Select communication wire between IDU and wired controller

Material type	Total length of communication line between IDU unit and wired controller L m(feet)	Wire size	Remarks

Light/Ordinary polyvinyl chloride sheathed cord.	$L \leq 250(820-1/5)$	2×AWG18~ 2×AWG16	<ol style="list-style-type: none"> <li>1. Total length of communication line can't exceed 250m (820-1/5feet).</li> <li>2. The cord shall be Circular cord (the cores shall be twisted together).</li> <li>3. If unit is installed in places with intense magnetic field or strong interference, it is necessary to use shielded wire.</li> </ol>
--	-----------------------	---------------------	--

For example, two wired controllers control multiple IDUs and the graphic of connection between IDU and wired controller is :

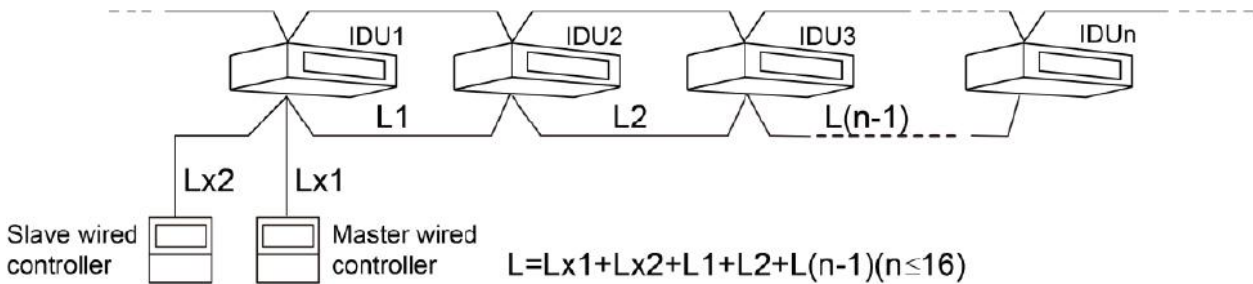

Fig.36

(2)Select communication wire between ODU and IDU

Material Type	Total Length L(m) of Communication Cable between IDU Unit and IDU (ODU ) Unit m(feet)	Wire size	Remarks
Light/Ordinary polyvinyl chloride sheathed cord.	$L \leq 1000(3280-5/6)$	$\geq 2 \times \text{AWG18}$	<ol style="list-style-type: none"> <li>1. If the wire diameter is enlarged to 2 ×AWG16, the total communication length can reach 1500m (4921-1/4feet).</li> <li>2. The cord shall be Circular cord (the cores shall be twisted together).</li> <li>3. If unit is installed in places with intense magnetic field or strong interference, it is necessary to use shielded wire.</li> </ol>

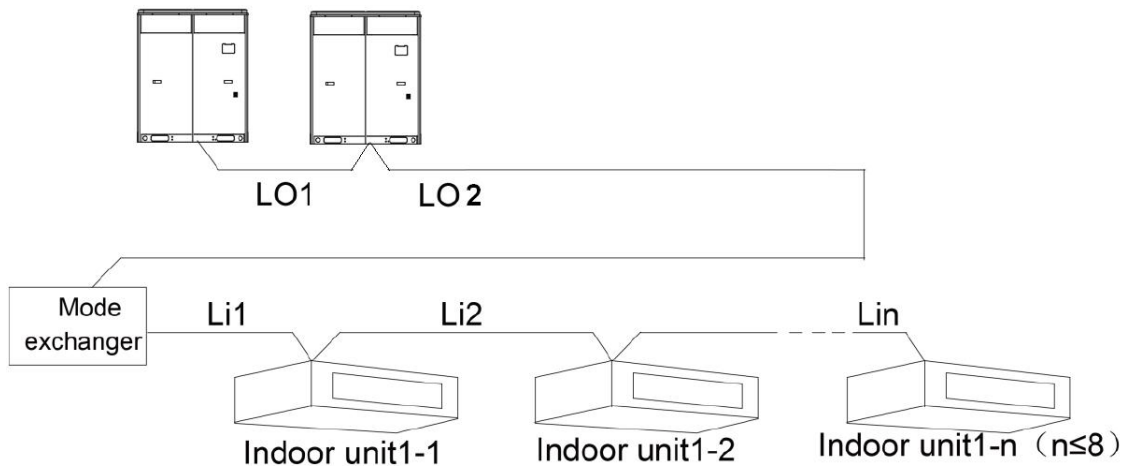

Fig.37

**NOTE:** All of the selected communication wire must be consistent with local laws and regulations.

4.7.3.2 Connection mode of communication

(1) All communication wires of Ultra Heat GMV must be connected in series rather than in star.

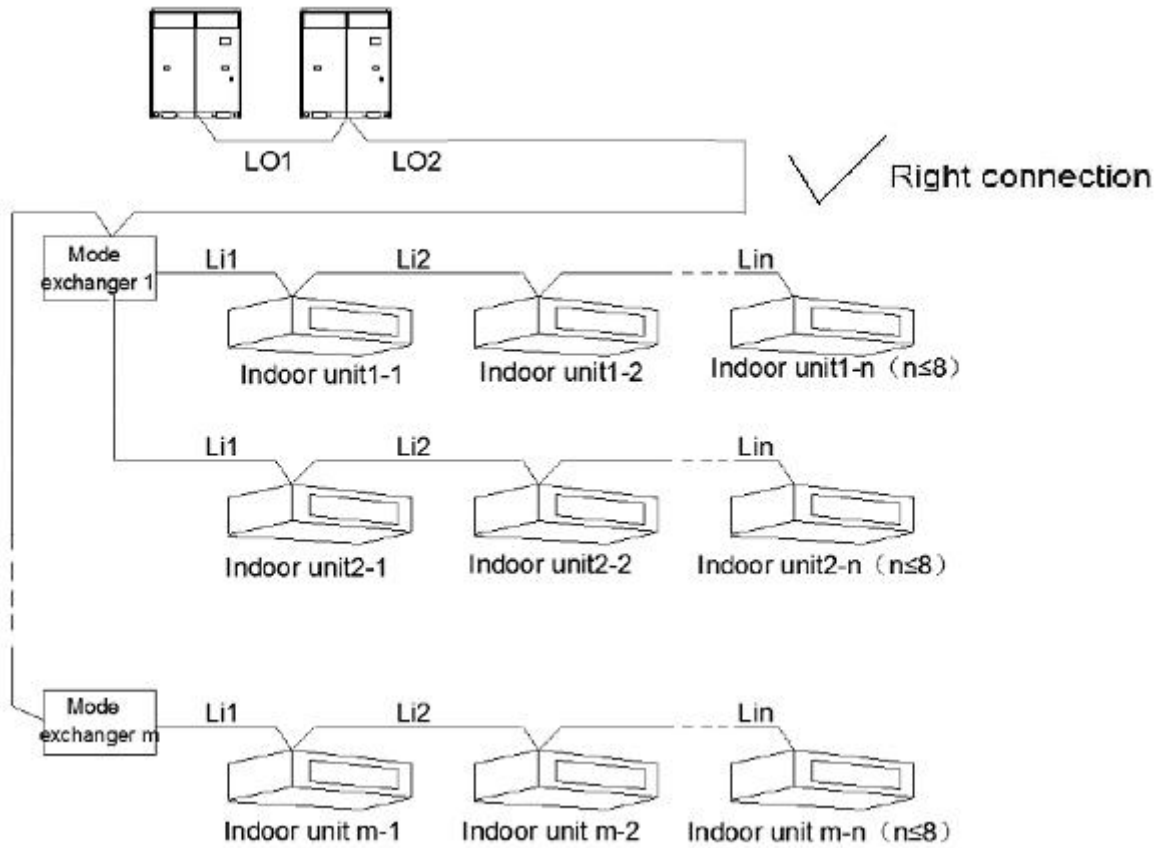

Fig.38

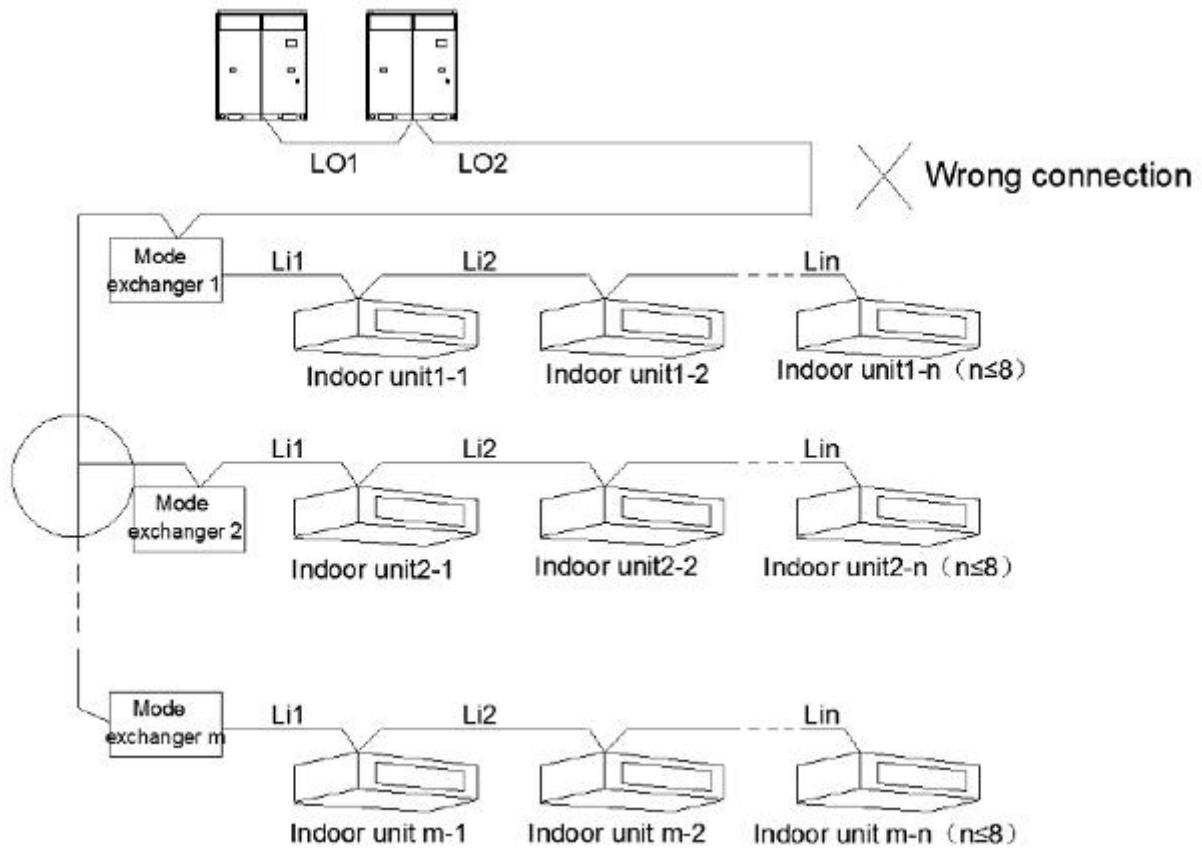

Fig.39

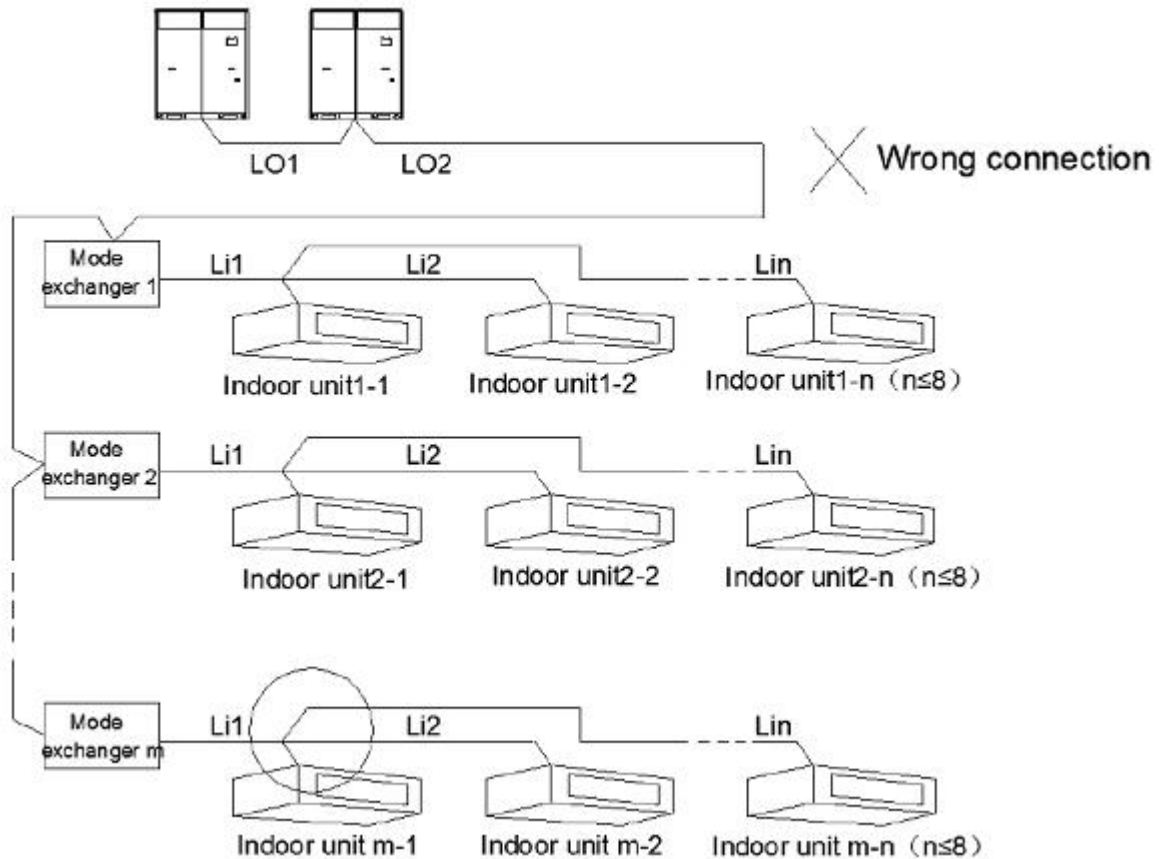

Fig.40

(2) All communication wires of Ultra Heat GMV are connected by screws.

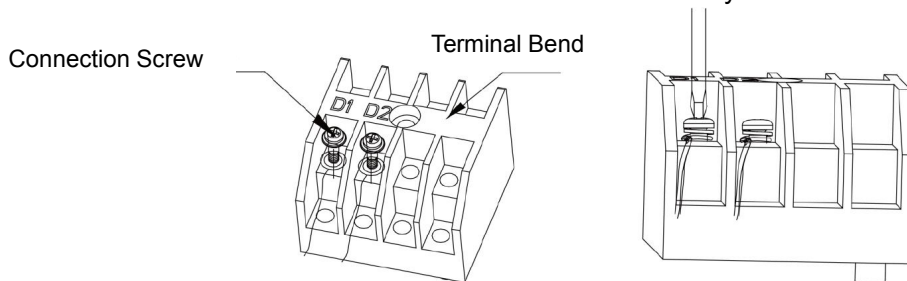

Fig.41

(3) If a single communication wire is not long enough and needs to be connected, the connected joint must be welded or pressure-welded. Do not simply twist the wires together.

#### 4.7.4 Communication address

Auto addressing technology is adopted for Ultra Heat GMV IDU and ODU. No need to set address codes manually. Only the addresses of ODU and central control are needed to be set (address of central control is only needed when there are multiple refrigeration systems).

**NOTICE!** When installing centralized controller or remote monitor, indoor units' project codes must be displaced. Otherwise, collision malfunction of the project codes will show. For detail operation methods, please refer to the *Ultra Heat GMV Technical Service Manual*.

### 4.8 Connection Method and Steps for System Communication

### 4.8.1 Communication connection between IDU and ODU

**NOTICE! The centralized controller can be installed when it is necessary.**

Connection of communication for single-module system and single-moudle mode exchanger system:

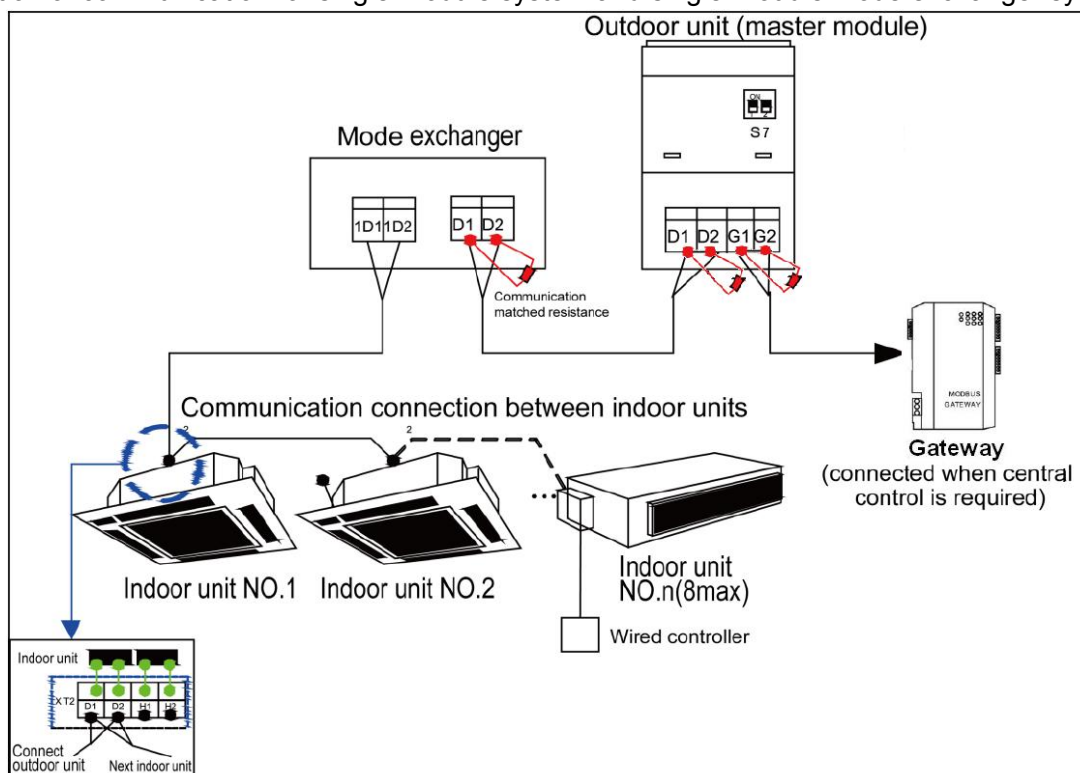

Fig.42

Connection of communication for single-module system and multi-module mode exchanger system:

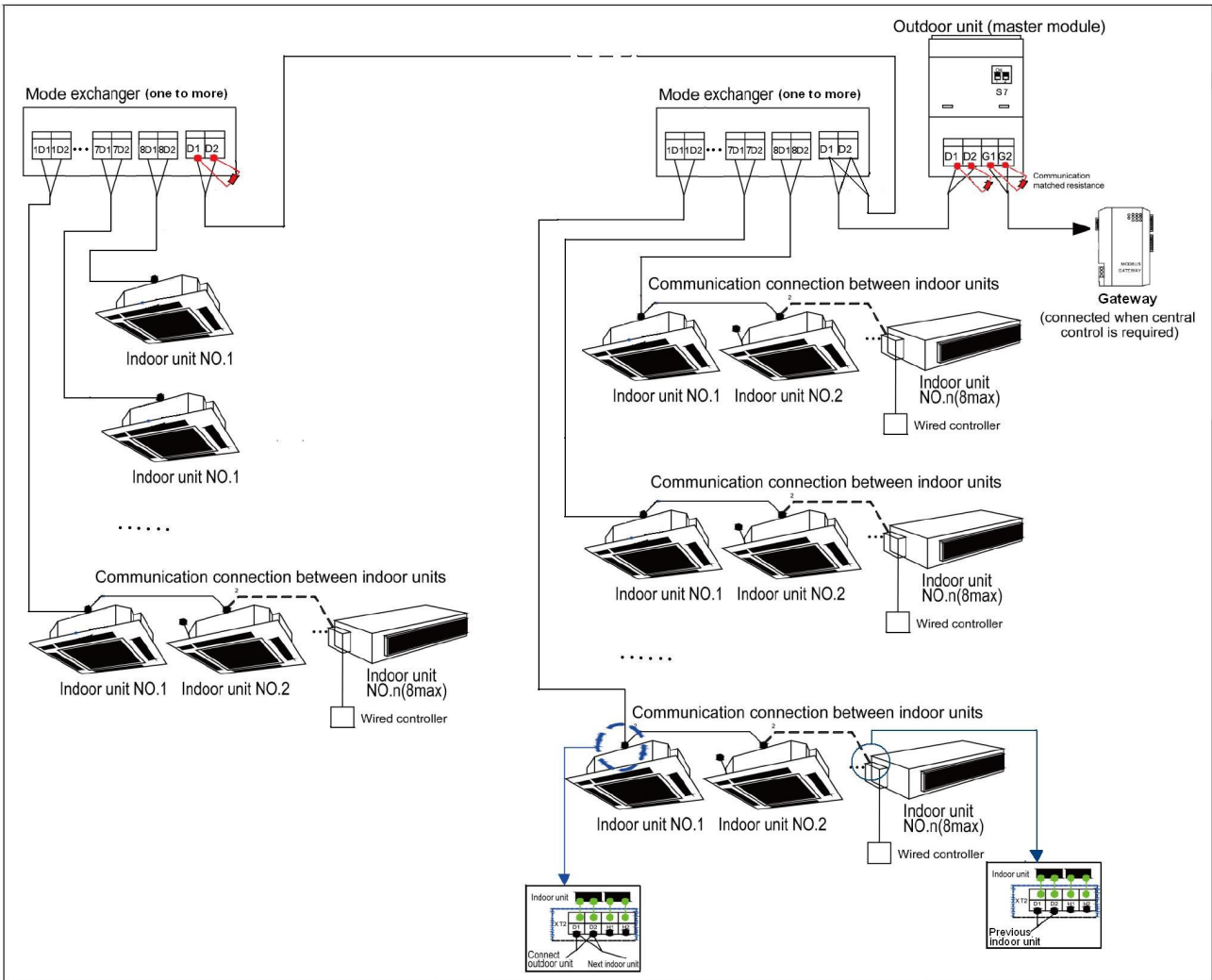

Fig.43



Connection of communication for multi-module system and multi-module mode exchanger system:

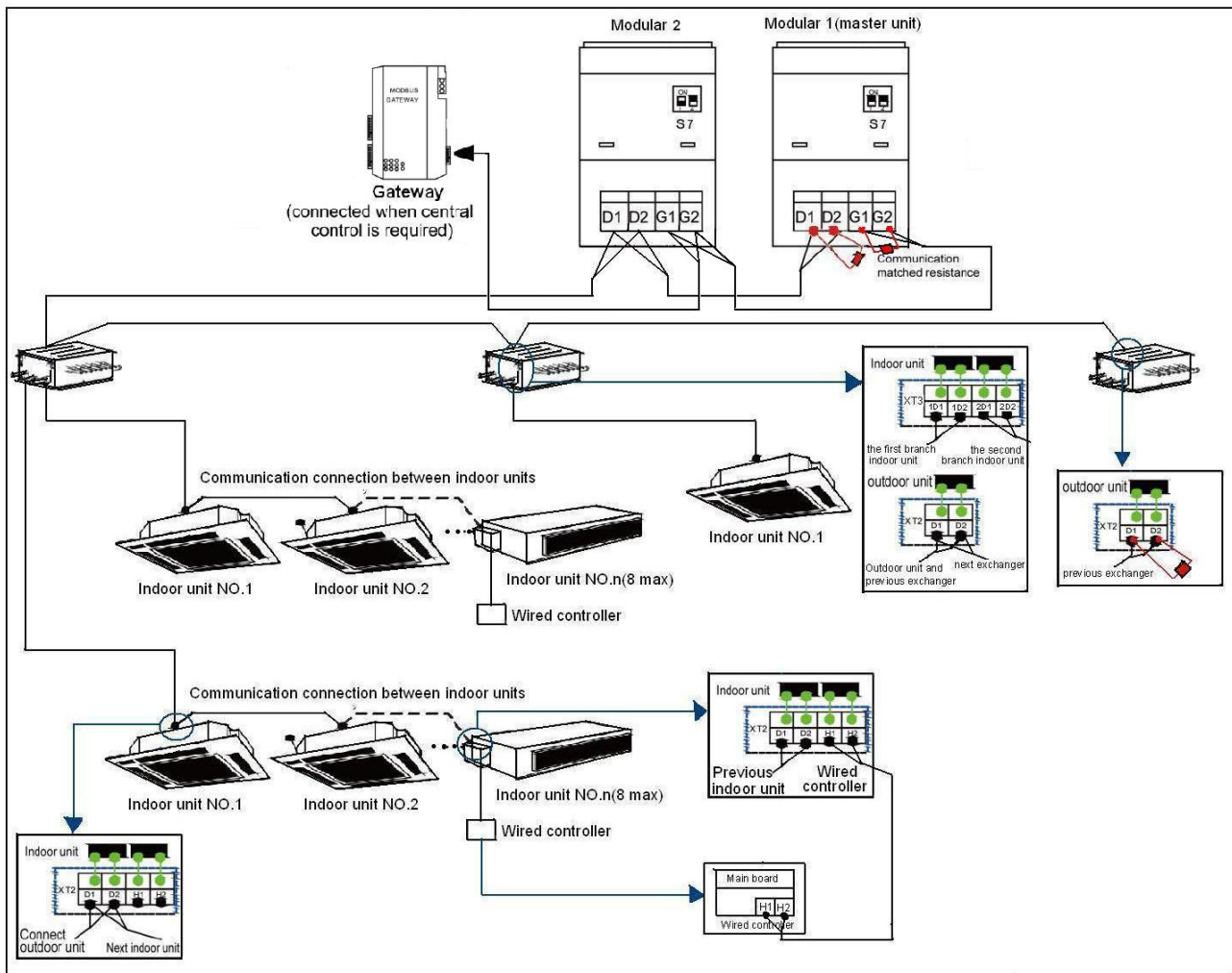

Fig.44

Connection of communication for multi refrigeration systems:

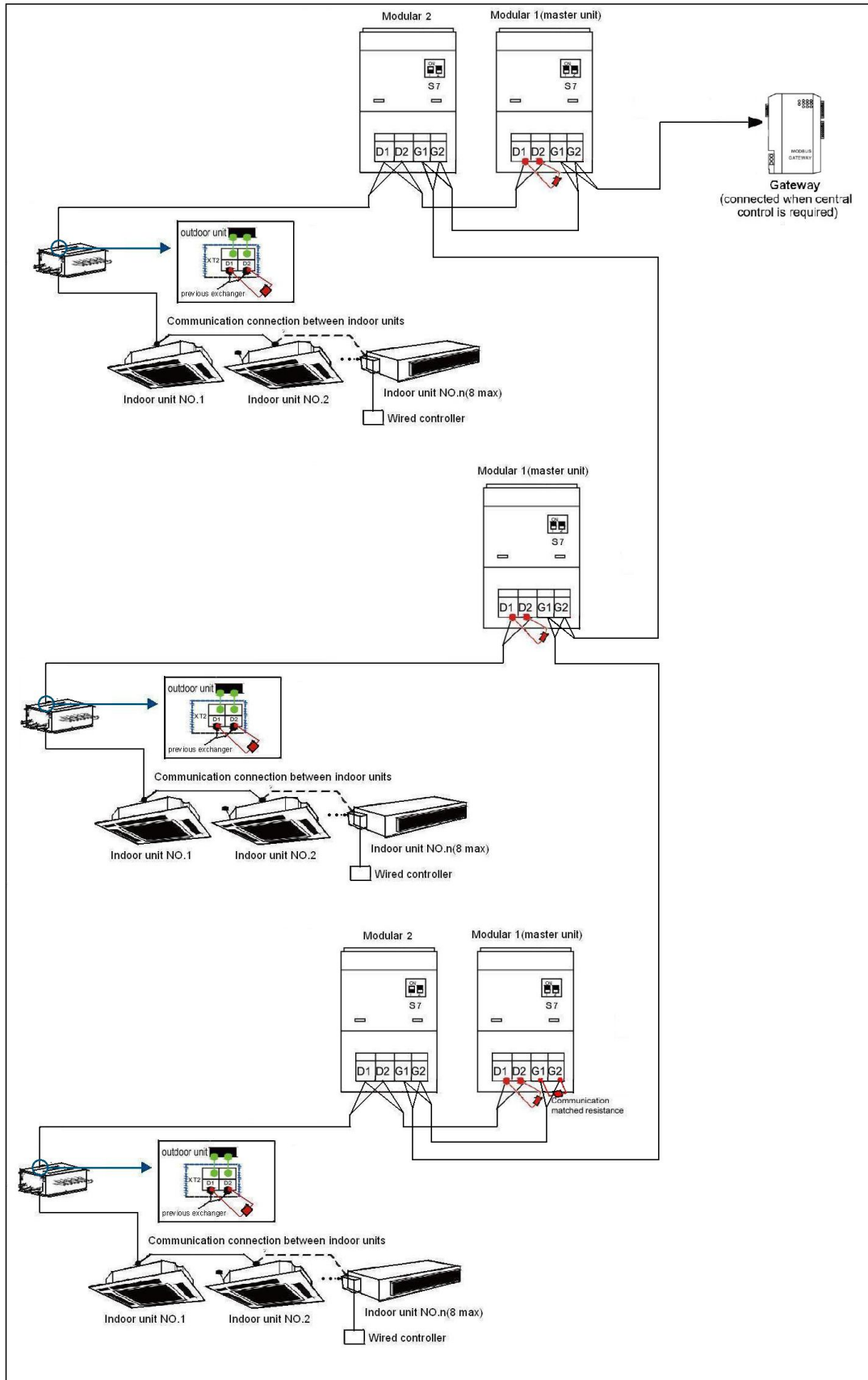

Fig.45

**NOTICE**

- (1) For modular outdoor units, if there are multiple outdoor modules, then the master unit must be the first outdoor module on the communication wire and should not connect with IDU (master unit is set by S7 of the outdoor main board).
- (2) For modular outdoor units, if there are multiple outdoor modules, then the indoor units must be connected with the last slave module of ODU (slave unit is set by S7 of the outdoor main board).
- (3) Communication wire and power cord must be separated.
- (4) Communication wire must be of proper length. Extension is not allowed.
- (5) IDUs must be connected in series. The last mode exchanger D1/D2 connecting with ODU must be connected with the communication matched resistance (supplied in the list of ODU spare parts). The ODU D1/D2 must be connected with the communication matched resistance (installed before factory).
- (6) For modular outdoor units, if there are multiple outdoor modules, the communication matched resistance (installed before factory) of slave modules connecting with D1/D2 must be removed.
- (7) For modular outdoor units, if there are multiple outdoor modules, S7 dip switch of master unit is “00”, and S7 dip switch of slave unit is “10”, otherwise, the system main board will display CJ which means address DIP switch code of system is shocking.
- (8) For multi-refrigeration systems, when it is necessary to connect with a centralized controller, the communication lines connecting with all the ODUs G1/G2 must be connected in series, and the last refrigeration system master unit G1/G2 must be connected with the communication matched resistance (supplied in the list of ODU spare parts).
- (9) For multi-refrigeration systems, the address dip switch S3 of the master unit must be set by different numbers according to Ultra Heat technical service manual, and slave unit S3 can't be set.

4.8.2 Communication connection between IDU and wired controller

There are 4 kinds of connection between IDU and wired controller, as shown below:

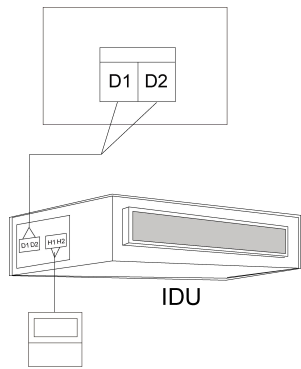

Fig.46 One wired controller controls one IDU

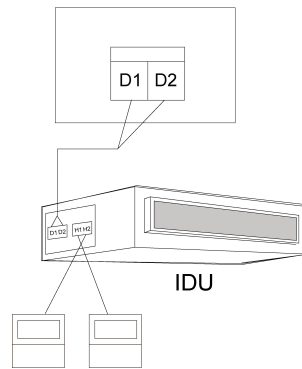

Fig.47 Two wired controller controls one

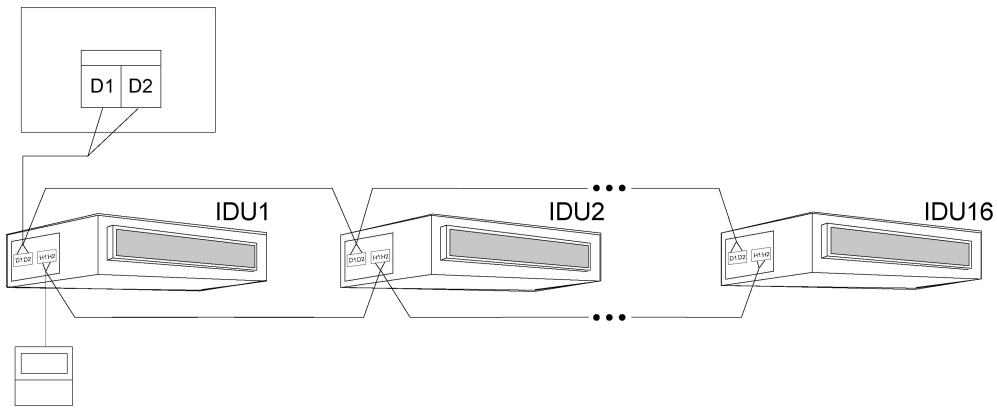

Fig.48 One wired controller controls multiple IDUs

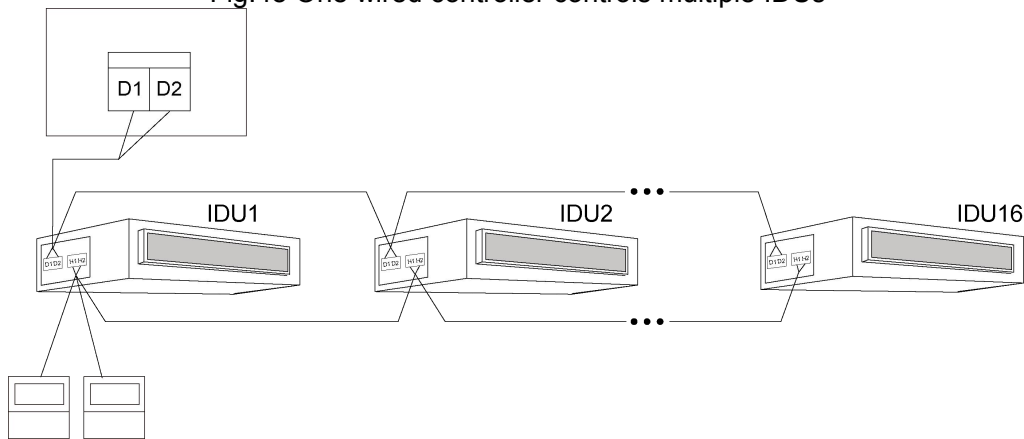

Fig.49 Two wired controllers control multiple IDUs

When two wired controllers control multiple IDUs, the wired controllers can be connected to any one IDU, provided that the connected IDU is of the same series. Meanwhile, one and only one of the wired controllers must be set as a slave controller. At most 16 IDUs can be controlled by the two wired controllers and the connected IDUs shall be within a same IDU network.

No matter when unit is turned on or off, slave controller can be set.

How to set a slave controller: hold “function” button on the designated controller for 5s, and temperature zone displays C00. Continue holding “function” button for 5s and setting screen of controller parameter will come out. Default temperature zone displays P00.

Press ▲ button or ▼ button to select parameter code P13. Press “mode” button to switch to setup of parameter values. Then the parameter value will blink. Press ▲ button or ▼ button to select code 02. And then press “confirm/cancel” to finish setting.

Press “confirm/cancel” to return to the previous display until you exit from the setup of parameter values.

Below are user’s parameter settings:

Parameter code	Parameter name	Parameter scope	Default value	Remark
P13	Set up address for wired controller	01: master wired controller 02: slave wired controller	01	When 2 wired controllers control one or more IDUs, they shall have different addresses. Slave wired controller (02) can’t set up units’ parameters except its own address.

### 4.8.3 Communication connection of central controlling units

**NOTICE! The centralized controller can be installed when it is necessary.**

Port connection G1 and G2 on the wiring board of master unit and slave unit among each multi VRF system (see below)

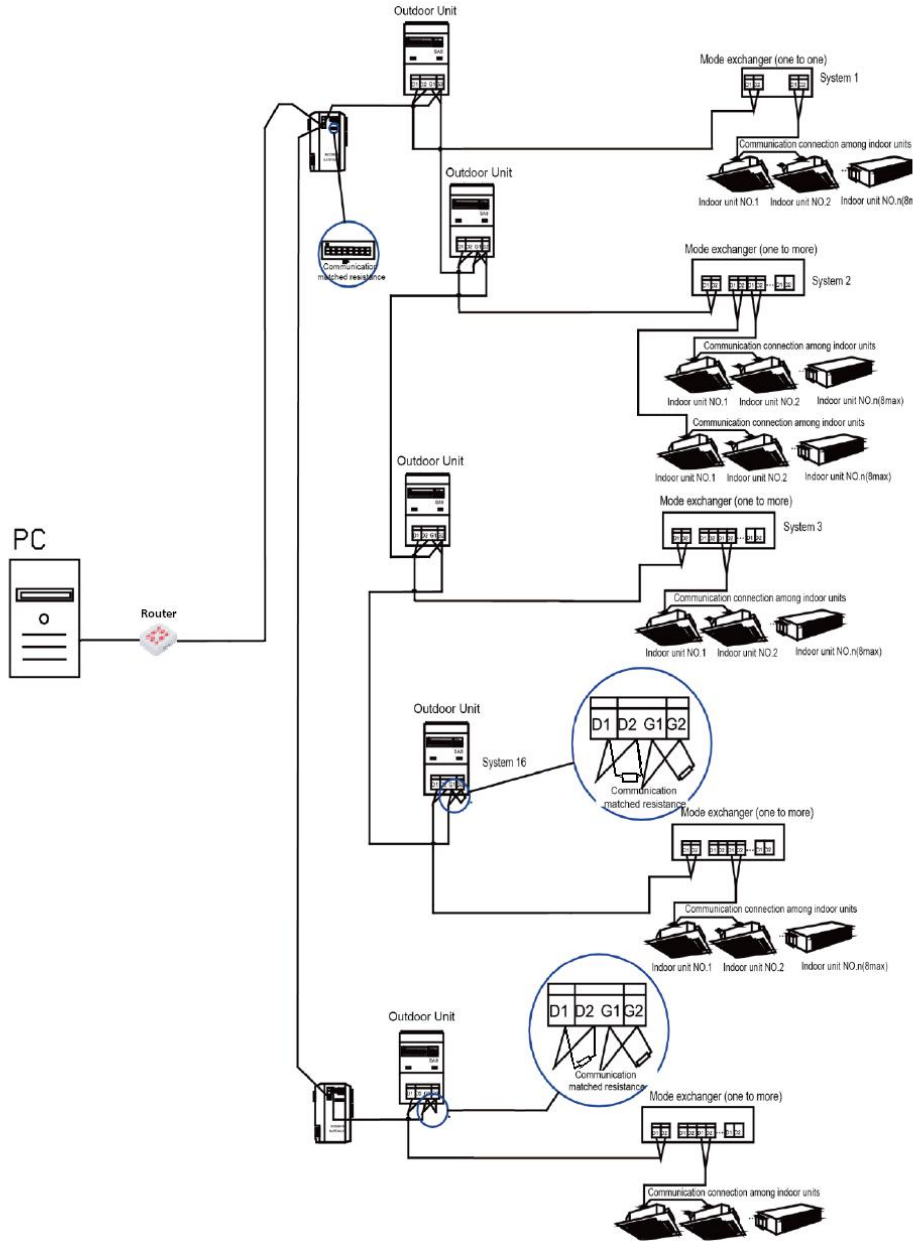

Fig.50

### 4.9 External Electrical Wiring Diagram



(1) Each unit should be equipped with a circuit breaker for short circuit protection and exceptional overload protection. In general, circuit breaker is at OFF status.

(2) During operation, all indoor units and outdoor units belonging to the same system must be kept energized status. Otherwise, the unit can't operate normally.

### 4.9.1 External wiring diagram of a single unit

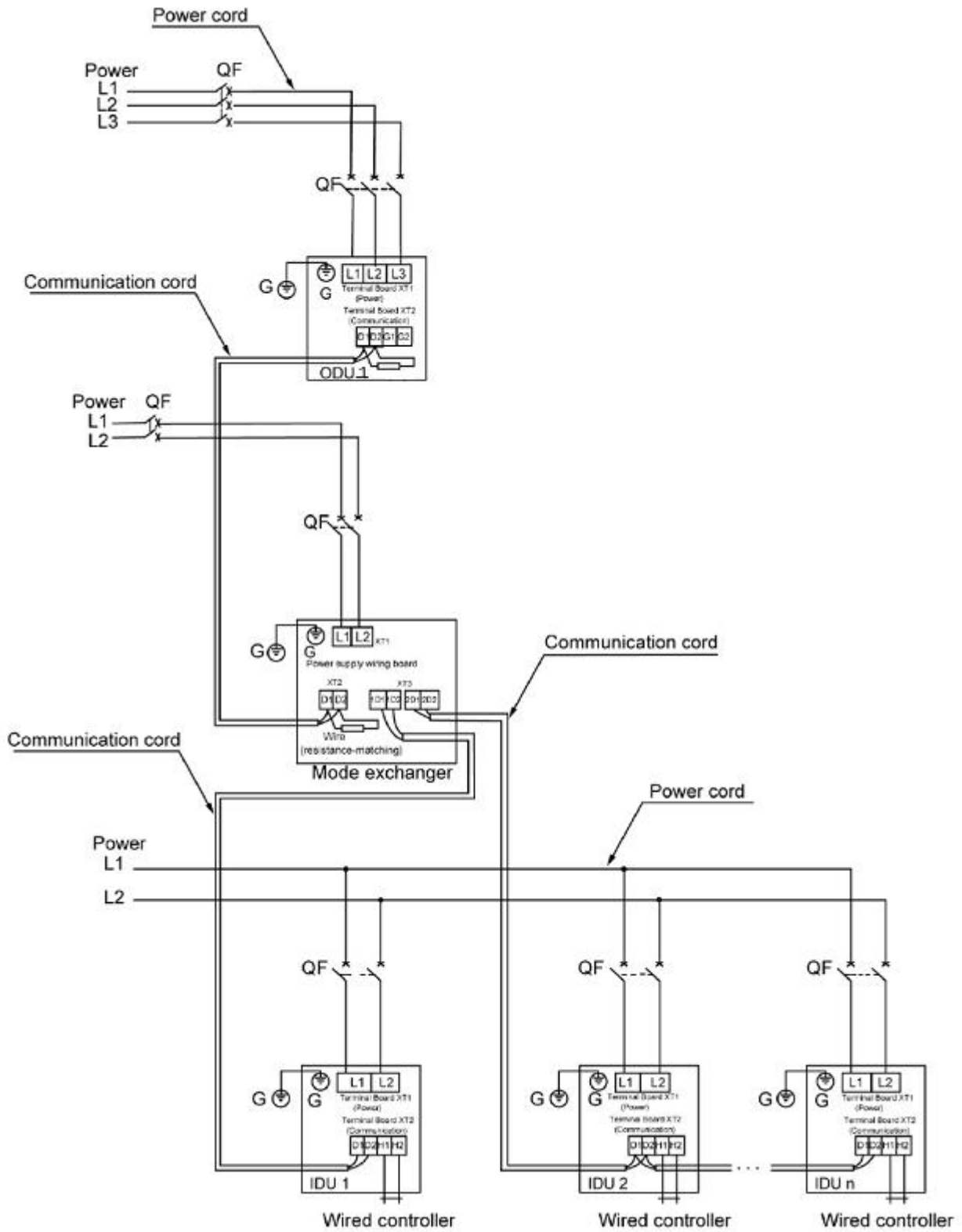

Fig.51

**NOTICE!** Maximum number of IDU is based upon ODU capacity. For details, please refer to the introduction of units' combination.

### 4.9.2 External wiring diagram of modular connection

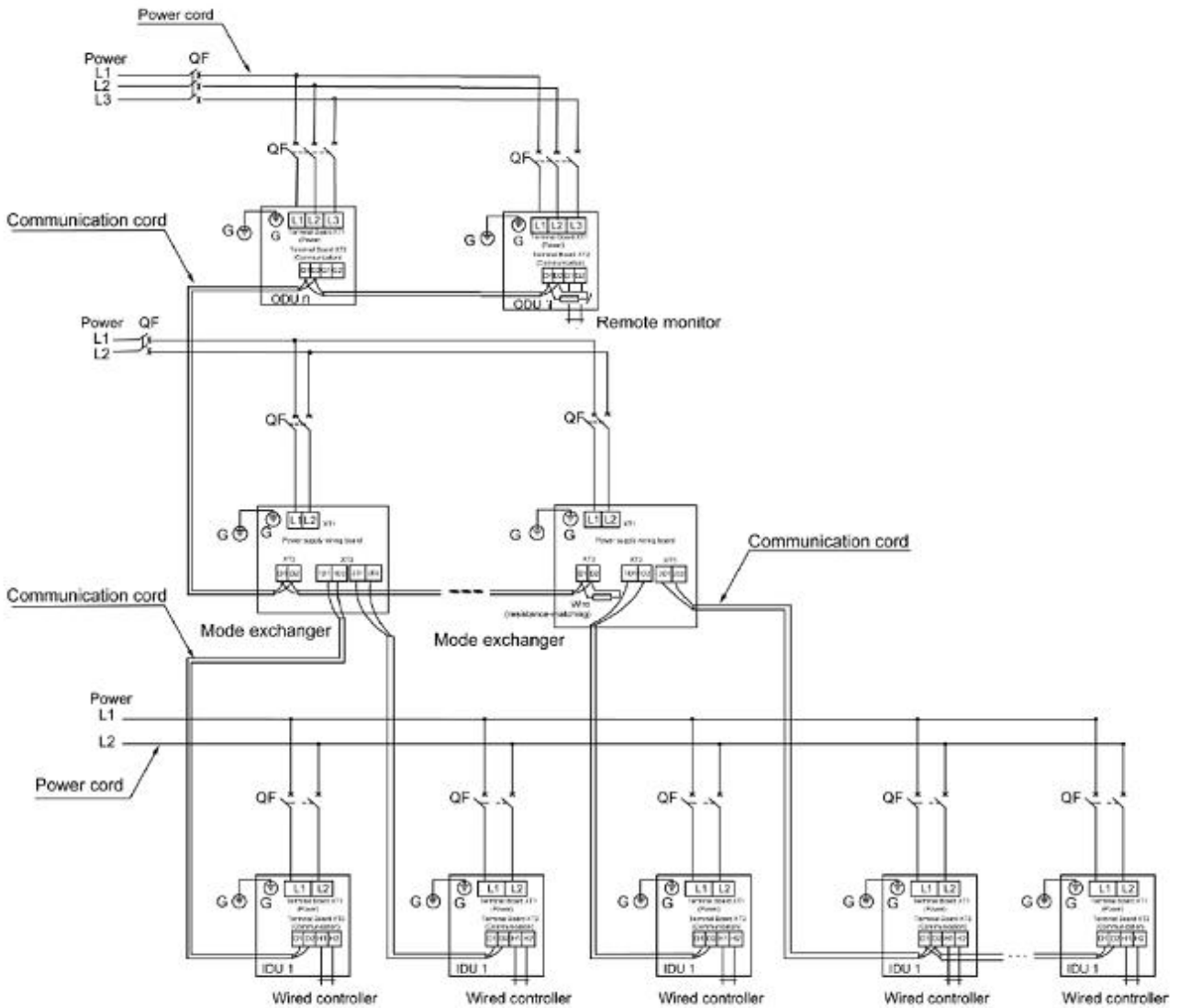

Fig.52

**NOTICE!** Maximum number of ODU (N) and maximum number of IDU (n) are based upon the combination type of ODU. For details, please refer to the introduction of unit combination.

### 4.10 Attention before operation

The installer should read the following items, and make sure that the metal parts supplied for transportation are taken down.

- 1) For safe handling, two metal parts are fixed at the feet of compressor before delivery (shown as follows):

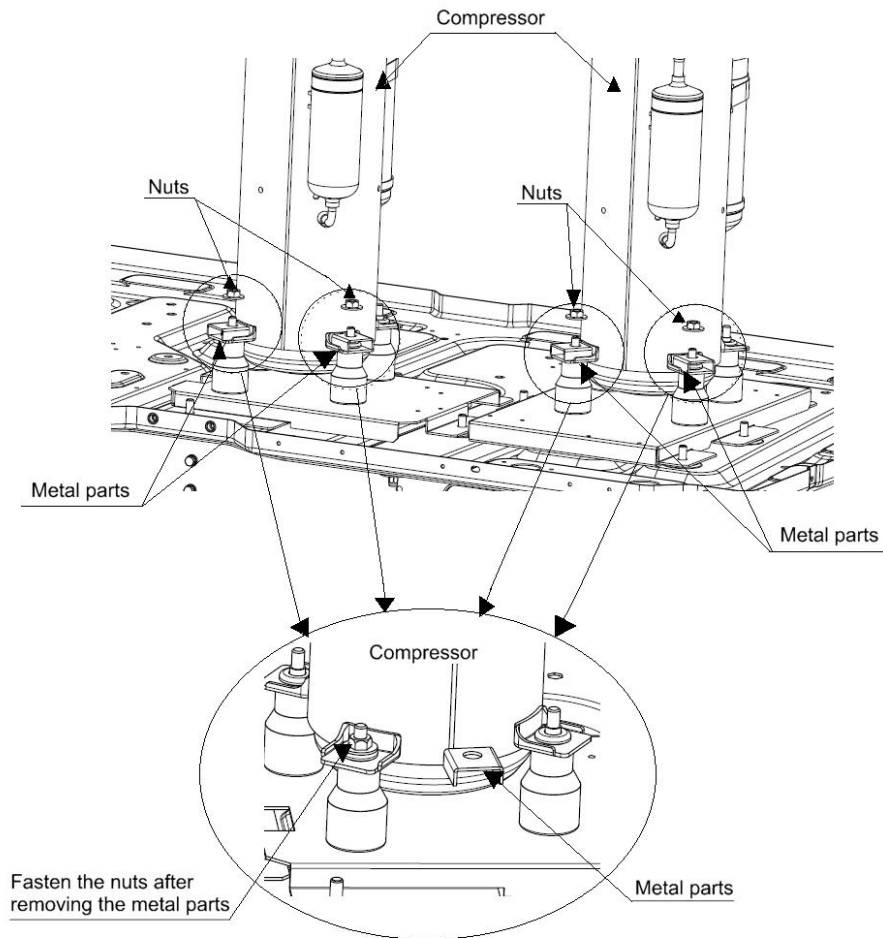

Fig.53

2) While installation, please make sure the metal parts are taken down. Then fasten the compressor fixed nuts again and re-wrap the soundproof material.



Note: if the unit is operating with the metal parts stay, it may lead to compressor abnormal vibration; even reduce the lifespan of the unit.



## 5 Check Items after Installation and Trial Run

### 5.1 Check Items after Installation

Check items	Possible conditions due to improper installation	Check
Each part of the unit is installed securely?	Unit may drop, shake or emit noise	
Gas leakage test is taken or not?	Insufficient cooling (heating) capacity	
Unit gets proper thermal insulation or not?	There may be condensation and dripping.	
Drainage is smooth or not?	There may be condensation and dripping.	
Is the voltage in accordance with the rated voltage specified on the nameplate?	Unit may have malfunction or components may get damaged.	
Is the electric wiring and pipe connection installed correctly?	Unit may have malfunction or components may get damaged.	
Unit is securely grounded or not?	Electrical leakage	
Power cord meets the required specification?	Unit may have malfunction or components may get damaged.	
Is the air inlet/outlet blocked?	Insufficient cooling (heating) capacity	
Length of refrigerant pipe and the charging amount of refrigerant are recorded or not?	The refrigerant charging amount is not accurate.	
Is the address code of outdoor modules and the code of module quantity correct?	The unit cannot run normally. Communication malfunction might happen.	
Is the address code of indoor units and wired controller correct?	The unit cannot run normally. Communication malfunction might happen.	
Has the communication line been connected correctly?	The unit cannot run normally. Communication malfunction might happen.	
Is the piping connection and valve status correct?	The unit cannot run normally. The unit might be damaged.	
Is the phase sequence of external power cord correct?	The unit cannot run normally. Phase sequence error may happen.	
Whether the engineering piping work and wiring holes are sealed?	Maybe there are mice biting the wires, which is the cause of malfunction.	
Whether the metal parts supplied for transportation are taken down?	Make sure that the metal parts supplied for transportation are taken down.	

### 5.2 Trial Run

**Note:** during debugging, one and only one module must be set as a master module.

When no special requirement is needed, no need to set other functions. Unit can operate according to ex-factory settings. When special requirement is needed, please read the Service Manual or Debugging and Maintenance Manual.

#### 5.2.1 Preparation before trial run

- (1) The power supply should be turned on only after finishing all the installation.
- (2) All the control wires and cables are connected correctly and safely. Completely open the gas and liquid valves.
- (3) All the objects like metal filling, thrum and clip should be cleared after installation.
- (4) Check if the unit appearance and piping system are damaged or not due to transportation.
- (5) Check if the terminals of electrical element are loose and the phase sequence is correct or not.

(6) Check the valve: fully open the gas and liquid valve.

### 5.2.2 Trial run

#### 5.2.2.1 Notices

(1) Before test operation, make sure unit is power on and compressor has been preheated for more than 8 hours. Touch the unit to check whether it's normally preheated. Start test operation after unit is normally preheated, otherwise compressor might be damaged. Debugging must be performed by professional technicians or under the guide of professional technicians.

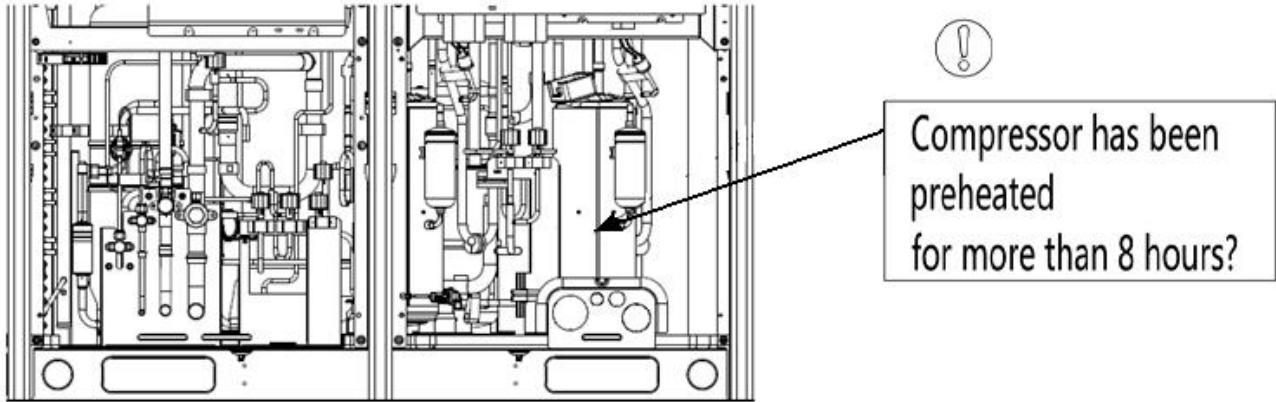

Fig.54

(2) When debugging starts, system will operate according to the ambient temperature.

1) When outdoor temperature is above 20° C(68°F), debugging shall be in cooling mode.

2) When outdoor temperature is below 20° C(68°F), debugging shall be in heating mode.

(3) Before debugging, confirm again whether the cut-off valve of each basic module is fully turned on.

(4) During debugging, front panel of the outdoor unit must be fully closed; otherwise, debugging accuracy will be affected (see below).

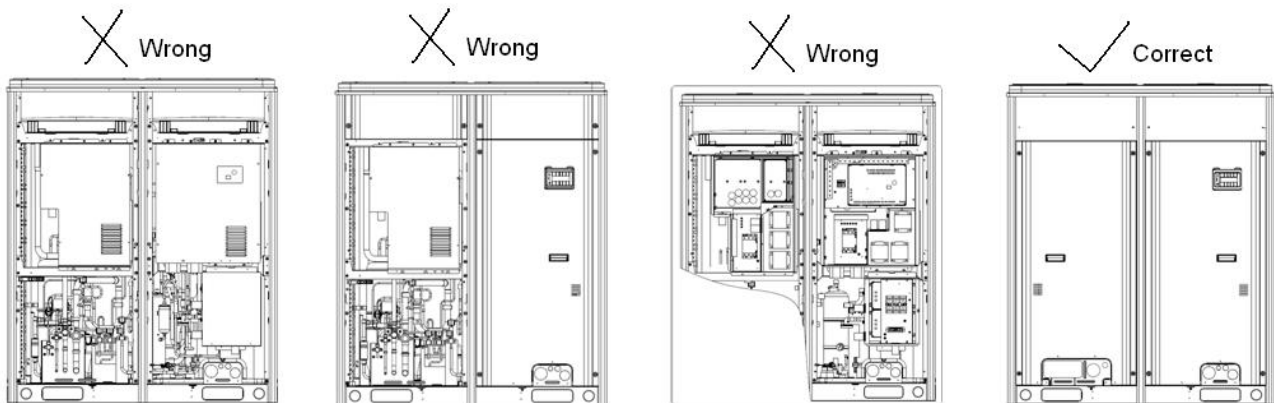

Fig.55

(5) Before debugging, make sure the needed amount of refrigerant has been added to the pipe or at least 70% of the needed refrigerant has been added.

(6) Description of each stage of debugging progress:

Description of each stage of debugging progress				
Progress	Debugging code LED1	Progress code LED2	Status code LED3	Meaning
—				

	Code	Display status	Code	Display status	Code	Display status	
01_Set master unit malfunction	A0	Light					System is not debugged.
	CC	Light					Master unit hasn't been set, please set it.
	CF	Light					Master unit is two or more than two. Please reset.
	CJ	Light					Address DIP switch code of system is shocking.
	db	Light	01	Light	oC	Light	Master unit has been set successfully. Next step will start automatically.
02_Allocate addresses	db	Light	02	Light	oC	Light	Address allocation is finished. Next step will start automatically.
03_Confirm the quantity of modules	db	Light	03	Blink	01~03	Blink	LED3 displays the quantity of module. In this case, please confirm if the quantity is correct manually.
	db	Light	03	Light	oC	Light	System has confirmed the quantity of module. Next step will start automatically.
04_Confirm the quantity of IDUs	db	Light	04	Blink	01~60	Blink	LED3 displays the quantity of IDU. In this case, please confirm if the quantity is correct manually.
	db	Light	04	Light	oC	Light	System has confirmed the quantity of IDU. Next step will start automatically.
05_Internal communication detection	C2	Light					Communication between master ODU and inverter compressor driver has error.
	C0	Light					Communication between master ODU and IDUs has error.
	db	Light	05	Light	oC	Light	System detection is done. Next step will start automatically.
06_Detect outdoor components	Error code	Light					System detects that outdoor components have error.
	db	Light	06	Light	oC	Light	System detects no error on outdoor components. Next step will start automatically.
07_Detect indoor components	XXXX/ Error code	Light					System detects error on indoor components. XXXX means the project code of IDU with error. 3s later, related error code will be displayed.
	db	Light	07	Light	oC	Light	System detects no error on indoor components. Next step will start automatically.
08_Confirm preheated compressor	db	Light	08	Light	on	Light	LED3 displays the on-off state of ODU valves connecting with IDU. In this case, please confirm if the ODU valves are open manually.
	db	Light	08	Light	U0/ Preheat time	Blink	U0 means preheat time for compressor is less than 8 hours.
	db	Light	08	Light	oC	Light	Compressor has been preheated for 8 hours. Next step will start automatically.
09_Refrigerant judgments before startup	U4	Light					System is lack of refrigerant.
	db	Light	09	Light	oC	Light	Refrigerant is normal. Next step will start automatically.

10_	---	---	---	---	---	---	No meaning.
11_	---	---	---	---	---	---	No meaning.
12_Confirm debugging startup	db	Light	12	Light	AE	Blink	Ready for units to start debugging.
	db	Light	12	Light	oC	Light	The unit starts up in the status of manual calculation of refrigerant charging amount.
13_	---	---	---	---	---	---	No meaning.
14_	---	---	---	---	---	---	No meaning.
15_Cooling debugging	db	Light	15	Light	UC	Light	Debugging for cooling mode. (Debugging operation mode, the system will select automatically with no need of manual setting).
	Error code	Light					Malfunction occurs when debugging for cooling mode.
16_Heating debugging	db	Light	16	Light	UH	Light	Debugging for heating mode. (Debugging operation mode, the system will select automatically with no need of manual setting).
	Error code	Light					Malfunction occurs when debugging for heating mode.

#### Display of related error code:

Malfunction Type	Error Code(for example)	Note
ODU malfunction	CC	Master unit hasn't been set. LED1 will display CC.
IDU malfunction	XXXX/d3	XXXX means the project code of IDU with error. 3s later, d3 will be displayed. For instance, if no.100 IDU has d3 error, then the LED1 will display circularly as below: 01(2s later), 00(2s later), d3.

#### 5.2.2.2 Debugging operation mode

Ultra Heat GMV multi VRF system has two debugging modes: one is direct operation on main board of outdoor units while the other is PC operation via special software. In PC software debugging, indoor/outdoor parameters can be displayed and historical data can be recorded and inquired. (Operation details can be found in relevant instruction manuals)

##### (1) Debugging through operation on main board of outdoor units

In this debugging mode, following debugging functions are included on the main board:

**Step 1:** Front panel of the outdoor units must be fully closed. Open the debugging window of each basic module.

**Step 2:** Disconnect power for outdoor units. According to design requirements of external static pressure, set up corresponding static pressure mode for the units. Setting methods can be seen in Outdoor Fan Static Pressure Setup S2 of Technical service manual; Low noise setting method can also be seen in low noise setting S1 of Technical service manual.

**Step 3:** Disconnect power for outdoor units and set one module as a master unit. Setting methods can be seen in Master Unit Setup S7 of Technical service manual (Set master unit S7 as "00"; Set slave

unit S7 as “10”).

**Step 4:** Connect power for all indoor units. Make sure all IDUs are power on. Then all outdoor modules will display “A0”.

**Step 5:** Find the module with “00” of S7 which is the master module. The main board shows:

Debugging code		Progress code		Status code	
LED1		LED2		LED3	
Code	Display status	code	Display status	Code	Display status
A0	Light			0	Light

Hold SW4 button on the master module for at least 6s to enable debugging. Then the main board shows:

Debugging code		Progress code		Status code	
LED1		LED2		LED3	
Code	Display status	code	Display status	Code	Display status
A0	Blink				

Press SW4 confirmation button on the master unit to confirm it. Unit will start debugging.

**Step 6:** Wait. Unit will then start progress 01.

If no error is detected, system will display as below and then start next progress.

—	Debugging code		Progress code		Status code	
progress	LED1		LED2		LED3	
	Code	Display status	code	Display status	Code	Display status
01_Set up master unit	db	Light	01	Light	oC	Light

If unit have some errors, progress 01 will show the following errors:

—	Debugging Code		Progress Code		Status Code		Meaning
Progress	LED1		LED2		LED3		
	Code	Display status	Code	Display status	Code	Display status	
01_Set up master unit	CC	Light					System doesn't have master unit. Reset master unit.
	CF	Light					More than 2 master units are set. Reset master unit.
	CJ	Light					Address DIP switch code of system is shocking.

According to the above errors, reset the master unit (Set master unit S7 as “00”; Set slave unit S7 as “10”), then start debugging again.

**Step 7:** Progress 02 is allocating addresses. If allocating addresses is done, then main board shows:

—	Debugging code		Progress code		Status code	
Progress	LED1		LED2		LED3	
	Code	Display status	Code	Display status	Code	Display status
02_Allocate addresses	db	Light	02	Light	oC	Light

**Step 8:** In progress 03, the quantity of modules needs to be confirmed manually. Main board will

display:

—	Debugging code		Progress code		Status code	
Progress	LED1		LED2		LED3	
	Code	Display status	Code	Display status	Code	Display status
03_Confirm the quantity of modules	db	Light	03	Light	Quantity of modules	Blink

If the quantity displayed is the same with actual quantity, then press SW4 confirmation button on the master unit to confirm it. Unit will start next progress:

—	Debugging code		Progress code		Status code	
Progress	LED1		LED2		LED3	
	Code	Display status	Code	Display status	Code	Display status
03_Confirm the quantity of modules	db	Light	03	Light	oC	Light

If the quantity displayed is different from actual quantity, then disconnect power and check whether communication wire among each module is correctly connected. After the check, start debugging again.

**Step 9:** In progress 04, the quantity of IDUs needs to be confirmed manually. Main board will display:

—	Debugging code		Progress code		Status code	
Progress	LED1		LED2		LED3	
	Code	Display status	Code	Display status	Code	Display status
04_Confirm the quantity of IDUs	db	Light	04	Light	Quantity of connected IDUs	Blink

If the quantity displayed is the same with actual quantity, then press SW4 confirmation button on the master unit to confirm it. Unit will start next progress:

—	Debugging code		Progress code		Status code	
Progress	LED1		LED2		LED3	
	Code	Display status	Code	Display status	Code	Display status
04_Confirm the quantity of IDUs	db	Light	04	Light	oC	Light

**Step 10:** Progress 05 is internal communication detection.

If no error is detected, system will display as below and then start next progress.

—	Debugging code		Progress code		Status code	
Progress	LED1		LED2		LED3	
	Code	Display status	Code	Display status	Code	Display status
05_Internal communication detection	db	Light	05	Light	oC	Light

If error is detected, system will stay at current progress. Error has to be solved manually. Related errors are:

—	Debugging Code		Progress Code		Status Code		Meaning
Progress	LED1		LED2		LED3		
	Code	Display status	Code	Display status	Code	Display status	

05_Internal communication detection	C2	Light					Communication between master ODU and inverter compressor driver has error.
	C0	Light					Communication between master ODU and IDUs has error.

Elimination methods of above errors can be found in Troubleshooting.

**Step 11:** Progress 06 is “Detect outdoor components”.

If no error is detected, system will display as below and then start next progress.

—	Debugging code		Progress code		Status code	
Progress	LED1		LED2		LED3	
	Code	Display status	Code	Display status	Code	Display status
06_Detect outdoor components	db	Light	06	Light	oC	Light

If error is detected, system will stay at current progress. Error has to be solved manually. Related errors are:

—	Debugging Code		Progress Code		Status Code		Meaning
Progress	LED1		LED2		LED3		
	Code	Display status	Code	Display status	Code	Display status	
06_Detect outdoor components	Error code	Light					System detects that outdoor components have error.

Elimination methods of above errors can be found in Troubleshooting.

**Step 12:** Progress 07 is “Detect indoor components”.

If no error is detected, system will display as below and then start next progress.

—	Debugging code		Progress code		Status code	
Progress	LED1		LED2		LED3	
	Code	Display status	Code	Display status	Code	Display status
07_Detect indoor components	db	Light	07	Light	oC	Light

If error is detected, system will stay at current progress. Error has to be solved manually. Related errors are:

—	Debugging Code		Progress Code		Status Code		Meaning
Progress	LED1		LED2		LED3		
	Code	Display status	Code	Display status	Code	Display status	
07_Detect indoor components	XXXX/ Error code	Light					System detects error on indoor components. XXXX means the project code of IDU with error. 3s later, related error code will be displayed.

Elimination methods of above errors can be found in Troubleshooting.

**Step 13:** Progress 08 is “Confirm preheated compressor”.

At first, make sure that the ODU valves connecting with IDU are opening. Main board will display:

—	Debugging code		Progress code		Status code	
Progress	LED1		LED2		LED3	
	Code	Display status	Code	Display status	Code	Display status

08_Confirm preheated compressor	db	Light	08	Light	on	Light
---------------------------------	----	-------	----	-------	----	-------

If the ODU valves connecting with IDU have been opened manually, then press SW4 confirmation button on the master unit to confirm it.

If ODU compressors have been preheated for more than 8h, system will display as below and start next progress.

—	Debugging code		Progress code		Status code	
	LED1		LED2		LED3	
	Code	Display status	code	Display status	Code	Display status
08_Confirm preheated compressor	db	Light	08	Light	oC	Light

If less than 8h of preheat time is detected, system will give error alarm and display as below. Then press SW4 confirmation button and SW2 button at the same time to skip the wait time and start next progress. But this will cause force start of the compressor, which may damage the compressor.

—	Debugging code		Progress code		Status code	
	LED1		LED2		LED3	
	Code	Display status	Code	Display status	Code	Display status
08_Confirm preheated compressor	db	Light	08	Light	U0/ Preheat time	Blink

**Step 14:** Progress 09 is “Refrigerant judgments before startup”.

If the refrigerant quantity inside the system meets the requirement of operation startup, system will display as below and start next progress.

—	Debugging code		Progress code		Status code	
	LED1		LED2		LED3	
	Code	Display status	code	Display status	Code	Display status
09_Refrigerant judgments before startup	db	Light	09	Light	oC	Light

If there's no or not enough refrigerant in the system to meet the requirement of operation startup, system will display U4 “refrigerant shortage protection” and fails to start next progress. Then check if there's any leakage or add refrigerant inside until error eliminates.

—	Debugging code		Progress code		Status code	
	LED1		LED2		LED3	
	Code	Display status	code	Display status	Code	Display status
09_Refrigerant judgments before startup	U4	Light				

**Step 15:** Progress 12 is “Confirm debugging startup”.

In order to make sure all preparation work is done before startup, this step is designed for user to confirm the startup again. Operate as below:

If master unit displays as below, system is waiting for confirmation signal.

—	Debugging code	Progress code	Status code



progress	LED1		LED2		LED3	
	Code	Display status	code	Display status	Code	Display status
12_Confirm debugging startup	db	Light	12	Light	AE	Light

If it's confirmed, press SW4 confirmation button. Then unit will display as below and start next progress.

—	Debugging code		Progress code		Status code	
progress	LED1		LED2		LED3	
	Code	Display status	code	Display status	Code	Display status
12_Confirm debugging startup	db	Light	12	Light	oC	Light

**Step 16:** After unit is confirmed to start debugging, system select cooling/heating mode according to ambient temperature automatically.

A If cooling mode is selected, relevant display is as below:

—	Debugging code		Progress code		Status code		Meaning
progress	LED1		LED2		LED3		
	Code	Display status	code	Display status	Code	Display status	
15_Cooling debugging	db	Light	15	Light	UC	Light	Debugging is enabled in cooling mode (debugging mode, auto-selected by system).
	Error code	Light					ODU Error occurs during debugging in cooling mode.
	XXXX/ Error code	Light					System detects error in indoor error. XXXX is the project code of the faulted IDU. 3s later, error code is displayed. For example, IDU no. 100 has d5 error, then LED3 displays like this: 01 (2s later) 00 (2s later) d5, and repeat again.

B If heating mode is selected, relevant display is as below:

—	Debugging code		Progress code		Status code		Meaning
progress	LED1		LED2		LED3		
	Code	Display status	code	Display status	Code	Display status	
16_Heating debugging	db	Light	16	Light	UH	Light	Debugging is enabled in heating mode (debugging mode, auto-selected by system).
	Error code	Light					ODU Error occurs during debugging in heating mode.
	XXXX/ Error code	Light					System detects error in indoor pipeline. XXXX is the project code of the faulted IDU. 3s later, error code is displayed. For example, IDU no. 100 has d5 error, then LED3 displays like this: 01 (2s later) 00 (2s later) d5, and repeat again.

**Step 17:** if there's no error during operation for about 30min, system will automatically confirm that

debugging is finished and then stop. System resumes standby condition.

**Step 18:** After debugging is finished, some functions can be set up according to project's actual needs. For specific details, please refer to System Functions Setup. If no special requirements, skip this step.

**Step 19:** deliver the product to user and inform user about usage precautions.

## 6 Common Malfunctions and Troubleshooting

Check the following items before contacting for repair.

Phenomenon	Reason	Measure
The unit doesn't run.	Without power supply	Connect to power supply
	Voltage is too low	Check if the voltage is within rating range
	Broken fuse or breaker trips off	Replace fuse or connect breaker
	Insufficient energy of remote controller	Replace new battery
	Remote controller is out of control scope	Control scope is within 8m
Unit runs but stop immediately	Air intake or outlet of indoor or outdoor unit is blocked	Remove obstruction
Abnormal cooling or heating	Air intake or outlet of indoor or outdoor unit is blocked	Remove obstruction
	Improper temperature setting	Adjust setting at wireless remote controller or wired controller
	Fan speed is set too low	Adjust setting at wireless remote controller or wired controller
	Wind direction is not correct	Adjust setting at wireless remote controller or wired controller
	Door or windows are opened	Close the door or windows
	Direct sunshine	Draw curtain or louver
	Too many people in the room	
	Too many heat resources in the room	Reduce heat resources
	Filter is blocked for dirt	Clean the filter

### **NOTICE**

(1) When installing remote monitor or central controller, displacement on indoor units' project codes must be made. Otherwise, there will be collision malfunction of the project codes. For detail operation methods, please refer to the Ultra Heat GMV Technical Service Manual.

(2) If problem cannot be solved after checking the above items, please contact Gree service center and show phenomena and models.

Following circumstances are not malfunction.

"Malfunction"		Reason
Unit doesn't run	When unit is started immediately after it is just turned off	Overload protection switch makes it run after 3 minutes delay
	When power is turned on	Standby operating for about 1 minute
Mist comes from the unit	Under cooling	Indoor high humidity air is cooled rapidly
Noise is emitted	Slight cracking sound is heard when just turned on	It is noise when electronic expansion valve initialization
	There is consecutive sound when cooling	That's sound for gas refrigerant flowing in unit
	There is sound when unit starts or stops	That's sound for gas refrigerant stops to flow
	There is slight and consecutive sound when unit is running or after running	That's sound for operation of drainage system
	Cracking sound is heard when unit is operating and after operating	That's sound caused by expansion of panel and other parts due to temperature change
The unit blows out duct	When unit runs after no operation for a long period	Dust in indoor unit is blew out
The unit emits odor	Operating	The room odor absorbed by the unit is blew out again
Indoor unit still runs after switch off	After every indoor unit receive "stop" signal, fan will keep running	Indoor fan motor will keep running 20-70s so as to take good use of excess cooling and heating and prepare for next operation
Mode conflict	COOL or HEAT mode cannot be operated	When the indoor operating mode conflicts with that of outdoor unit, indoor fault indicator will flash and conflict will be shown on the wired controller after 5 minutes. Indoor unit stops to run and meanwhile change outdoor operating mode as the same as that of indoor unit, then the unit will go back to normal. COOL mode doesn't conflict with DRY mode. FAN mode doesn't conflict with any mode.

## 7 Error Indication

Inquiry method of error indication: combine division symbol and content symbol to check the corresponding error.

Indoor:

Error Code	Content	Error Code	Content
L0	Malfunction of IDU	d2	Malfunction of lower water temperature sensor of water tank
L1	Protection of indoor fan	d3	Malfunction of ambient temperature sensor
L2	Auxiliary heating protection	d4	Malfunction of entry-tube temperature sensor
L3	Water-full protection	d6	Malfunction of exit-tube temperature sensor
L4	Abnormal power supply for wired controller	d7	Malfunction of humidity sensor
L5	Freeze prevention protection	d8	Malfunction of water temperature sensor
L7	No main IDU	d9	Malfunction of jumper cap
L8	Power supply is insufficient	dA	Web address of IDU is abnormal
L9	For single control over multiple units, number of IDU is inconsistent	dH	PCB of wired controller is abnormal
LA	For single control over multiple units, IDU series is inconsistent	dC	Setting capacity of DIP switch code is abnormal
LH	Alarm due to bad air quality	dL	Malfunction of air outlet temperature sensor
LC	IDU is not matching with ODU or IDU running mode is inconsistent with ODU allowed mode	dE	Malfunction of indoor CO2 sensor
LL	Malfunction of water flow switch	dF	Malfunction of upper water temperature sensor of water tank
LE	Rotation speed of EC DC water pump is abnormal	dJ	Malfunction of backwater temperature sensor
LF	Malfunction of shunt valve setting	dP	Malfunction of inlet tube temperature sensor of generator
LJ	Setting of functional DIP switch code is wrong	dU	Malfunction of drainage pipe temperature sensor of generator
LP	Zero-crossing malfunction of PG motor	db	Debugging status
LU	Indoor unit's branch is not inconsistent for one-to-more unit of heat recovery system	dd	Malfunction of solar power temperature sensor
d1	Indoor PCB is poor	dn	Malfunction of swing parts

## Outdoor:

Error Code	Content	Error Code	Content
E0	Malfunction of ODU	FA	Limited frequency reduction for high pressure protection
E1	High-pressure protection	FH	Limited frequency reduction for low pressure protection
E2	Discharge low-temperature protection	FC	Limited frequency reduction for power protection
E3	Low-pressure protection	FL	Limited frequency reduction for IPM temperature protection
E4	High discharge temperature protection of compressor	FE	Current sensor of compressor 4 is abnormal
Ey	Outdoor ambient temperature is beyond normal range	FF	Current sensor of compressor 5 is abnormal
En	compressor power protection	FJ	Current sensor of compressor 6 is abnormal
J0	Protection for other modules	FP	Malfunction of DC motor
J1	Over-current protection of compressor 1	FU	Malfunction of casing top temperature sensor of compressor 1
J2	Over-current protection of compressor 2	Fb	Malfunction of casing top temperature sensor of compressor 2
J3	Over-current protection of compressor 3	Fd	Malfunction of exit tube temperature sensor of mode exchanger
J4	Over-current protection of compressor 4	Fn	Malfunction of inlet tube temperature sensor of mode exchanger
J5	Over-current protection of compressor 5	b1	Malfunction of outdoor ambient temperature sensor
J6	Over-current protection for compressor 6	b2	Malfunction of defrosting temperature sensor 1
J7	Gas-mixing protection of 4-way valve	b3	Malfunction of defrosting temperature sensor 2
J8	High pressure ratio protection of system	b4	Malfunction of liquid temperature sensor of sub-cooler
J9	Low pressure ratio protection of system	b5	Malfunction of gas temperature sensor of sub-cooler
JA	Protection because of abnormal pressure	b6	Malfunction of inlet tube temperature sensor of vapor liquid separator
JC	Water flow switch protection	b7	Malfunction of exit tube temperature sensor of vapor liquid separator
JL	Protection because high pressure is too low	b8	Malfunction of outdoor humidity sensor
JE	Oil-return pipe is blocked	b9	Malfunction of gas temperature sensor of heat exchanger
JF	Oil-return pipe is leaking	bA	Malfunction of oil-return temperature sensor 1
P0	malfunction of driving board of compressor	bH	Clock of system is abnormal
P1	Driving board of compressor operates abnormally	bC	Protection because the temperature sensor at the top of compressor 1 is loose
P2	Voltage protection of driving board power of compressor	bL	Protection because the temperature sensor at the top of compressor 2 is loose
P3	Reset protection of driving module of compressor	bE	Malfunction of inlet tube temperature sensor of condenser
P4	Drive PFC protection of compressor	bF	Malfunction of outlet tube temperature sensor of condenser
P5	Over-current protection of inverter compressor	bJ	High-pressure sensor and low-pressure sensor are connected reversely
P6	Drive IPM module protection of compressor	bP	Malfunction of temperature sensor of oil-return 2
P7	Malfunction of drive temperature sensor of compressor	bU	Malfunction of temperature sensor of oil return 3
P8	Drive IPM high temperature protection of compressor	bb	Malfunction of temperature sensor of oil return 4

Error Code	Content	Error Code	Content
P9	Desynchronizing protection of inverter compressor	H0	Malfunction of driving board of fan
PA	Malfunction of drive storage chip of compressor	H1	Driving board of fan operates abnormally
PH	High-voltage protection of compressor's drive DC bus bar	H2	Voltage protection of driving board power of fan
PC	Malfunction of current detection circuit drive of compressor	H3	Reset protection of driving module of fan
PL	Low voltage protection for DC bus bar of drive of compressor	H4	Drive PFC protection of fan
PE	Phase-lacking of inverter compressor	H5	Over-current protection of inverter fan
PF	Malfunction of charging loop of driven of compressor	H6	Drive IPM module protection of fan
PJ	Failure startup of inverter compressor	H7	Malfunction of drive temperature sensor of fan
PP	AC current protection of inverter compressor	H8	Drive IPM high temperature protection of fan
PU	AC input voltage of drive of inverter compressor	H9	Desynchronizing protection of inverter fan
Pn	Drive IPM high temperature protection of PFC	HA	Malfunction of drive storage chip of inverter outdoor fan
F0	Main board of ODU is poor	HH	High-voltage protection of fan's drive DC bus bar
F1	Malfunction of high-pressure sensor	HC	Malfunction of current detection circuit of fan drive
F2	Malfunction of middle-pressure sensor	HL	Low voltage protection of bus bar of fan drive
F3	Malfunction of low-pressure sensor	HE	Phase-lacking of inverter fan
F5	Malfunction of discharge temperature sensor of compressor 1	HF	Malfunction of charging loop of fan drive
F6	Malfunction of discharge temperature sensor of compressor 2	HJ	Failure startup of inverter fan
F7	Malfunction of discharge temperature sensor of compressor 3	HP	AC current protection of inverter fan
F8	Limited frequency reduction for AC current protection	HU	AC input voltage of drive of inverter fan
F9	Limited frequency reduction for discharge temperature protection	L6	IDU running mode is inconsistent with ODU allowed mode

## Debugging:

Error Code	Content	Error Code	Content
U0	Preheat time of compressor is insufficient	C6	Alarm because ODU quantity is inconsistent
U2	Wrong setting of ODU's capacity code/jumper cap	C7	Abnormal communication of converter
U3	Power supply phase sequence protection	C8	Emergency status of compressor
U4	Refrigerant-lacking protection	C9	Emergency status of fan
U5	Wrong address for driving board of compressor	CA	Emergency status of module
U6	Alarm because valve is abnormal	CH	Rated capacity is too high
U8	Malfunction of pipeline for IDU	CC	No main outdoor unit
U9	Malfunction of pipeline for ODU	CL	The matching ratio of rated capacity for IDU and ODU is too low
UC	Setting of main IDU is succeeded	CE	Communication malfunction between mode exchanger and IDU
UL	Emergency operation DIP switch code of compressor is wrong	CF	Malfunction of multiple main control units
UE	Charging of refrigerant is invalid	CJ	Address DIP switch code of system is shocking
UF	Identification malfunction of IDU of mode exchanger	CP	Malfunction of multiple wired controller
C0	Communication malfunction between IDU, ODU and IDU's wired controller	CU	Communication malfunction between IDU and the receiving lamp
C1	Communication malfunction between main control and DC-DCcontroller	Cb	Overflow distribution of IP address
C2	Communication malfunction between main control and inverter compressor driver	Cd	Communication malfunction between mode exchanger and ODU
C3	Communication malfunction between main control and inverter fan driver	Cn	Malfunction of network for IDU and ODU of mode exchanger
C4	Malfunction of lack of IDU	Cy	Communication malfunction of mode exchanger
C5	Alarm because project code of IDU is inconsistent		



## Status:

Error Code	Content	Error Code	Content
A0	Unit waiting for debugging	Ay	Shielding status
A2	Refrigerant recovery operation of after-sales	n0	SE operation setting of system
A3	Defrosting	n3	Compulsory defrosting
A4	Oil-return	n4	Limit setting for max. capacity/output capacity
A6	Heat pump function setting	n5	Compulsory excursion of engineering code of IDU
A7	Quiet mode setting	n6	Inquiry of malfunction
A8	Vacuum pump mode	n7	Inquiry of parameters
AH	Heating	n8	Inquiry of project code of IDU
AC	Cooling	n9	Check quantity of IDU on line
AL	Charge refrigerant automatically	nA	Heat pump unit
AE	Charge refrigerant manually	nH	Heating only unit
AF	Fan	nC	Cooling only unit
AJ	Cleaning reminding of filter	nE	Negative code
AP	Debugging confirmation when starting up the unit	nF	Fan model
AU	Long-distance emergency stop	nJ	High temperature prevention when heating
Ab	Emergency stop of operation	nU	Eliminate the long-distance shielding command of IDU
Ad	Limit operation	nb	Bar code inquiry
An	Child lock status	nn	Length modification of connection pipe of ODU

Note: For detailed malfunction and maintenance, please refer to the engineering debugging and after-sales maintenance manual.

## 8 Maintenance and Care

Regular check, Maintenance and care should be performed every six months by professional personnel, which will prolong the unit life span. Disconnect the power supply before cleaning and maintenance.

### 8.1 Outdoor Heat Exchanger

Outdoor heat exchanger is required to be cleaned once every six months. Use vacuum cleaner with nylon brush to clean up dust and sundries on the surface of heat exchanger. Blow away dust by compressed air if it is available. Never use water to wash the heat exchanger.

### 8.2 Drain Pipe

Regularly check if the drain pipe is clogged in order to drain condensate smoothly.

### 8.3 Notice before Seasonal Use

(1) Check if the inlet/outlet of the indoor/outdoor unit is clogged.

(2) Check if the ground wire is earthed reliably.

(3) Check if battery of remote wireless controller has been replaced.

(4) Check if the filter screen has been set soundly.

(5) After long period of shutdown, open the main power switch 8 hours before reoperating the unit so as to preheat the compressor crankcase.

(6) Check if the outdoor unit is installed firmly. If there is something abnormal, please contact the GREE appointed service center.

### 8.4 Maintenance after Seasonal Use

(1) Cut off main power supply of the unit.

(2) Clean filter screen and indoor and outdoor units.

(3) Clean the dust and sundries on the indoor and outdoor units.

(4) In the event of rusting, use the anti-rust paint to stop spreading of rust.

### 8.5 Parts Replacement

Purchase parts from Gree appointed service center or dealer if necessary.

Note:

During airtight and leakage test, never mix oxygen, ethyne and other dangerous gas into refrigeration circuit. In case of hazard, it's better to use nitrogen or refrigerant to accomplish such test.

## 9 After-sales Service

In case the air-conditioning unit you bought has any quality problem or you have any inquiry, please contact the local after-sales service agency designated by Gree.

Warranty should meet the following requirements:

- (1) First run of the unit should be operated by professional personnel from Gree appointed service center.
- (2) Only Gree manufactured accessories can be used on the machine.
- (3) All the instructions listed in this manual should be followed.
- (4) Warranty will be automatically invalid if fails to obey any item mentioned above.

**GREE ELECTRIC APPLIANCES, INC. OF ZHUHAI**

---

Add: West Jinji Rd, Qianshan, Zhuhai, Guangdong, China, 519070  
Tel: (+86-756) 8522218 Fax: (+86-756) 8669426  
E-mail: [gree@gree.com.cn](mailto:gree@gree.com.cn) [www.gree.com](http://www.gree.com)



600005000720