



Owner's Manual

Original Instructions
Commercial Air Conditioners

GMV DC Inverter VRF

Models:

GMV-72WM/B-U(U)

GMV-96WM/B-U(U)

GMV-120WM/B-U(U)

.....

GMV-360WM/B-U(U)

Thank you for choosing commercial air conditioners. Please read this Owner's Manual carefully before operation and retain it for future reference.

If you have lost the Owner's Manual, please contact the local agent or visit www.gree.com or send an email to global@cn.gree.com for the electronic version.

GREE ELECTRIC APPLIANCES, INC. OF ZHUHAI

Preface

Gree DC Inverter Multi VRF System, with the most advanced technologies in the world, uses eco-friendly refrigerant R410A as its cooling medium. For correct installation and operation, please read this manual carefully.

⚠ DANGER	This is the safety alert symbol. It is used to alert you to potential personal injury hazards. Obey all safety messages that follow this symbol to avoid possible injury or death.
⚠ WARNING	This mark indicates procedures which, if improperly performed, might lead to the death or serious injury of the user.
⚠ CAUTION	This mark indicates procedures which, if improperly performed, might possibly result in personal harm to the user, or damage to property.
NOTICE	NOTICE is used to address practices not related to personal injury.

⚠ WARNING	
(1)	Instructions for installation and use of this product are provided by the manufacturer.
(2)	Installation must be performed in accordance with the requirements of NEC and CEC by authorized personnel only.
(3)	For safety operation, please strictly follow the instructions in this manual.
(4)	During operation, the gross rated capacity of working IDU should be within the gross rated capacity of ODU. Otherwise, IDU's cooling/heating performance will be reduced.
(5)	This manual must be in the hands of direct operators or maintenance men.
(6)	In case of malfunction and operation failure, please examine the following items and contact our authorized service centers as soon as possible. 1) Nameplate (model, cooling capacity, product code, ex-factory date). 2) Malfunction status (detail description of conditions before and after malfunction occurs).
(7)	All units have been strictly tested and proved to be qualified before ex-factory. To avoid unit damage or even operation failure which may be caused by improper disassembly, please do not disassemble units by yourself. If disassembly is needed, please contact our authorized service centers for help.
(8)	All graphics and information in this manual are only for reference. Manufacturer reserves the right for changes in terms of sales or production at any time and without prior notice.
(9)	If the supply cord is damaged, it must be replaced by the manufacturer, its service agent or similarly qualified persons in order to avoid a hazard.

This appliance can be used by children aged from 8 years and above and persons with reduced physical, sensory or mental capabilities or lack of experience and knowledge if they have been given supervision or instruction concerning use of the appliance in a safe way and understand the hazards involved. Children shall not play with the appliance. Cleaning and user maintenance shall not be made by children without supervision.



DISPOSAL: Do not dispose this product as unsorted municipal waste. Collection of such waste separately for special treatment is necessary.

Exception Clauses

Manufacturer will bear no responsibilities when personal injury or property loss is caused by the following reasons:

(1) Damage the product due to improper use or misuse of the product;

(2) Alter, change, maintain or use the product with other equipment without abiding by the instruction manual of manufacturer;

(3) After verification, the defect of product is directly caused by corrosive gas;

(4) After verification, defects are due to improper operation during transportation of product;

(5) Operate, repair, maintain the unit without abiding by instruction manual or related regulations;

(6) After verification, the problem or dispute is caused by the quality specification or performance of parts and components that produced by other manufacturers;

(7) The damage is caused by natural calamities, bad using environment or force majeure.

Contents

1 Safety Precautions.....	1
2 Product Introduction	2
2.1 Names of Main Parts	2
2.2 Combinations of Outdoor Units	2
2.3 Combinations of Indoor and Outdoor Units	3
2.4 The Range of Production Working Temperature	3
3 Preparation before Installation	4
3.1 Standard Parts	4
3.2 Installation Site	4
3.3 Piping Work Requirements	8
4 Installation Instruction	9
4.1 ODU Foundation.....	9
4.2 Physical Dimension of the Outdoor Unit and Mounting Hole	9
4.3 Connection Pipe	11
4.4 Installation of the Connection Pipe.....	20
4.5 Air Purging and Refrigerant Charge	24
4.6 Electric Wiring.....	28
4.7 System Communication	30
4.8 Connection Method and Steps for System Communication.....	33
4.9 External Electrical Wiring Diagram.....	38
5 Check Items after Installation and Trial Run.....	38
5.1 Check Items after Installation.....	38
5.2 Trial Run	39
6 Common Malfunction and Troubleshooting.....	50
7 Error Indication	52
8 Maintenance and Care.....	55
8.1 Outdoor Heat Exchanger	56
8.2 Drain Pipe.....	56
8.3 Notice before Seasonal Use	56
8.4 Maintenance after Seasonal Use	56
8.5 Parts Replacement	56
9 After-sales Service.....	56

1 Safety Precautions

WARNING

- | | |
|------|--|
| (1) | This product can't be installed at corrosive, inflammable or explosive environment or the place with special requirements, such as kitchen. Otherwise, it will affect the normal operation or shorten the service life of the unit, or even cause fire hazard or serious injury. As for above special places, please adopt special air conditioner with anti-corrosive or anti-explosion function. |
| (2) | Follow this instruction to complete the installation work. Please carefully read this manual before unit startup and service. |
| (3) | Wire size of power cord should be large enough. The damaged power cord and connection wire should be replaced by exclusive cable. |
| (4) | After connecting the power cord, please fix the electric box cover properly in order to avoid accident. |
| (5) | Never fail to comply with the nitrogen charge requirements. Charge nitrogen when welding pipes. |
| (6) | Never short-circuit or cancel the pressure switch to prevent unit damage. |
| (7) | Please firstly connect the wired controller before energization, otherwise wired controller cannot be used. |
| (8) | Before using the unit, please check if the piping and wiring are correct to avoid water leakage, refrigerant leakage, electric shock, or fire etc. |
| (9) | Do not insert fingers or objects into air outlet/inlet grille. |
| (10) | Open the door and window and keep good ventilation in the room to avoid oxygen deficit when the gas/oil supplied heating equipment is used. |
| (11) | Never start up or shut off the air conditioner by means of directly plug or unplug the power cord. |
| (12) | Turn off the unit after it runs at least five minutes; otherwise it will influence oil return of the compressor. |
| (13) | Do not allow children operate this unit. |
| (14) | Do not operate this unit with wet hands. |
| (15) | Turn off the unit or cut off the power supply before cleaning the unit, otherwise electric shock or injury may happen. |
| (16) | Never spray or flush water towards unit, otherwise malfunction or electric shock may happen. |
| (17) | Do not expose the unit to the moist or corrosive circumstances. |
| (18) | Under cooling mode, please don't set the room temperature too low and keep the temperature difference between indoor and outdoor unit within 5°C(41°F). |
| (19) | User is not allowed to repair the unit. Fault service may cause electric shock or fire accidents. Please contact Gree appointed service center for help. |
| (20) | Before installation, please check if the power supply is in accordance with the requirements specified on the nameplate. And also take care of the power safety. |
| (21) | Installation should be conducted by dealer or qualified personnel. Please do not attempt to install the unit by yourself. Improper handling may result in water leakage, electric shock or fire disaster etc. |
| (22) | Be sure to use the exclusive accessory and part to prevent the water leakage, electric shock and fire accidents. |
| (23) | Make sure the unit can be earthed properly and soundly after plugging into the socket so as to avoid electric shock. Please do not connect the ground wire to gas pipe, water pipe, lightning rod or telephone line. |
| (24) | Electrify the unit 8 hours before operation. Please switch on for 8 hours before operation. Do not cut off the power when 24 hours short-time halting (to protect the compressor). |
| (25) | If refrigerant leakage happens during installation, please ventilate immediately. Poisonous gas will emerge if the refrigerant gas meets fire. |
| (26) | Volatile liquid, such as diluent or gas will damage the unit appearance. Only use soft cloth with a little neutral detergent to clean the outer casing of unit. |
| (27) | If anything abnormal happens (such as burning smell), please power off the unit and cut off the main power supply, and then immediately contact Gree appointed service center. If abnormality keeps going, the unit might be damaged and lead to electric shock or fire. |

GREE will not assume responsibility of personal injury or equipment damage caused by improper installation and commission, unnecessary service and incapable of following the rules and instructions listed in this manual.

2 Product Introduction

Gree Multi VRF Modular System adopts inverter compressor technology. According to change the displacement of compressor, stepless capacity regulation within range of 10%-100% can be realized. Various product lineup is provided with capacity range from 72kBtu/h to 360kBtu/h, which can be widely used in working area and especially applicable to the place with variable load change. Gree air conditioner is absolutely your best choice.

2.1 Names of Main Parts

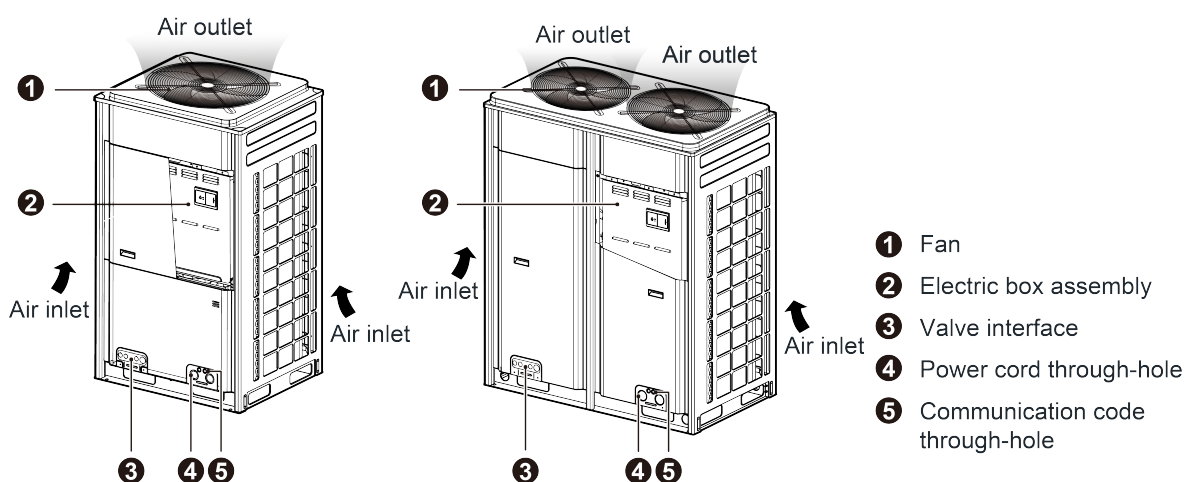

Fig.2.1

2.2 Combinations of Outdoor Units

Model (Single)	GMV-144WM/B-U(U)	GMV-168WM/B-U(U)	GMV-192WM/B-U(U)
Model (Combined)	GMV-72WM/B-U(U) + GMV-72WM/B-U(U)	GMV-72WM/B-U(U) + GMV-96WM/B-U(U)	GMV-96WM/B-U(U) + GMV-96WM/B-U(U)
Model (Single)	GMV-216WM/B-U(U)	GMV-240WM/B-U(U)	GMV-264WM/B-U(U)
Model (Combined)	GMV-96WM/B-U(U) + GMV-120WM/B-U(U)	GMV-120WM/B-U(U) + GMV-120WM/B-U(U)	GMV-72WM/B-U(U) + GMV-96WM/B-U(U) + GMV-96WM/B-U(U)
Model (Single)	GMV-288WM/B-U(U)	GMV-312WM/B-U(U)	GMV-336WM/B-U(U)
Model (Combined)	GMV-96WM/B-U(U) + GMV-96WM/B-U(U) + GMV-96WM/B-U(U)	GMV-96WM/B-U(U) + GMV-96WM/B-U(U) + GMV-120WM/B-U(U)	GMV-96WM/B-U(U) + GMV-120WM/B-U(U) + GMV-120WM/B-U(U)
Model (Single)	GMV-360WM/B-U(U)		
Model (Combined)	GMV-120WM/B-U(U) + GMV-120WM/B-U(U) + GMV-120WM/B-U(U)		

2.3 Combinations of Indoor and Outdoor Units

ODU Model	Max number of connectable IDU (unit)	ODU Model	Max number of connectable IDU (unit)
GMV-72WM/B-U(U)	13	GMV-240WM/B-U(U)	39
GMV-96WM/B-U(U)	16	GMV-264WM/B-U(U)	46
GMV-120WM/B-U(U)	19	GMV-288WM/B-U(U)	50
GMV-144WM/B-U(U)	23	GMV-312WM/B-U(U)	53
GMV-168WM/B-U(U)	29	GMV-336WM/B-U(U)	56
GMV-192WM/B-U(U)	33	GMV-360WM/B-U(U)	59
GMV-216WM/B-U(U)	36	—	—

The total capacity of indoor units should be within 50%~135% of that of outdoor units.

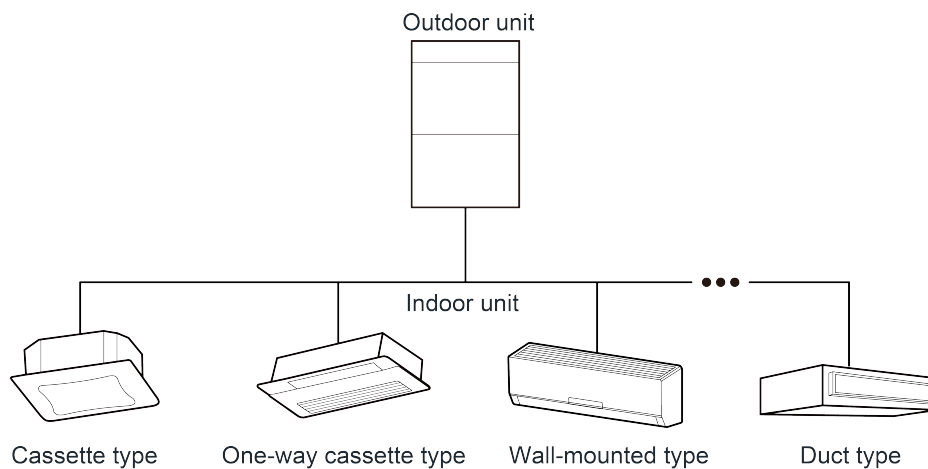

Fig.2.3

Fig.2.3 is the combination view of the ODU of Modular DC Inverter Multi VRF System and the IDU of Multi VRF System. IDU can be cassette type, one-way cassette type, wall-mounted type, duct type, etc. When any one IDU receives operation signal, ODU will start to work according to the capacity; when all IDUs stop, ODU will also stop.

2.4 The Range of Production Working Temperature

Cooling	Ambient temperature: -5°C(23°F)~52°C(125.6°F)
Heating	Ambient temperature: -20°C(-4°F)~24°C(75.2°F)

When the indoor units are all VRF fresh air processor, the unit operating range is as follows:

Cooling	Ambient temperature: 16°C(60.8°F)~45°C(113°F)
Heating	Ambient temperature: -7°C(19.4°F)~16°C(60.8°F)



NOTICE Out of the working Temperature Range may damage this product and will invalidate the warranty.

3 Preparation before Installation

NOTICE The picture is only used for reference and the actual product prevails. Unspecified measure unit is mm(inch).

3.1 Standard Parts

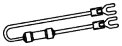
Please use the following standard parts supplied by Gree.

Parts for Outdoor Unit				
Number	Name	Picture	Quantity	Remarks
1	Owner's Manual		1	—
2	Wiring (match with resistance)		1	Must be connected to the last IDU of communication connection
3	Mark (Master)		2	Attach on the wired controller of master IDU or on the front panel

3.2 Installation Site

⚠ WARNING
(1) Install the unit at a place where is adequate to withstand the weight of the unit and make sure the unit would not shake or fall off.
(2) Never expose the unit under direct sunshine and rainfall. Install the unit at a place where is against dust, typhoon and earthquake.
(3) Try to keep the unit away from combustible, inflammable and corrosive gas or exhaust gas.
(4) Leave some space for heat exchanging and servicing so as to guarantee unit normal operation.
(5) Keep the indoor and outdoor units close to each other as much as possible so as to decrease the pipe length and bends.
(6) Never allow children to approach to the unit and take measures to prevent children touching the unit.

3.2.1 When the outdoor unit is totally surrounded by walls, please refer to following figures for space dimension.

3.2.1.1 Space dimension for single-module unit

Unit: mm(inch)

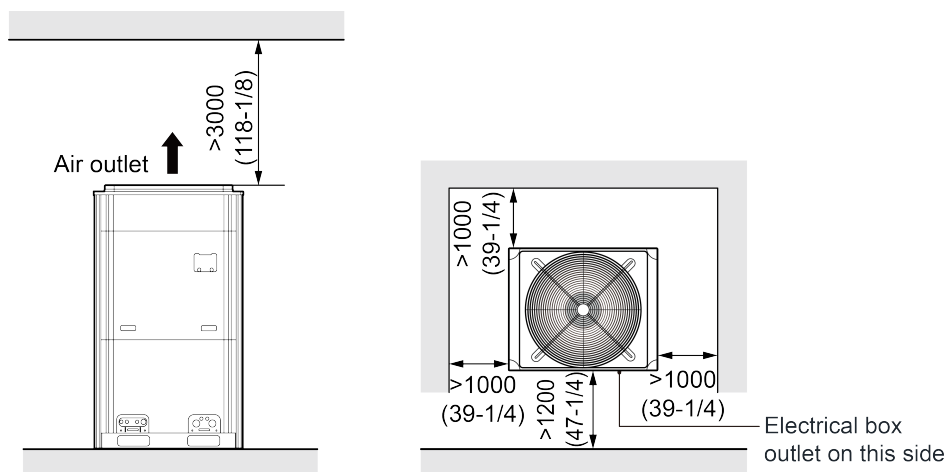

Fig.3.2.1

3.2.1.2 Space dimension for dual-module unit

Unit: mm(inch)

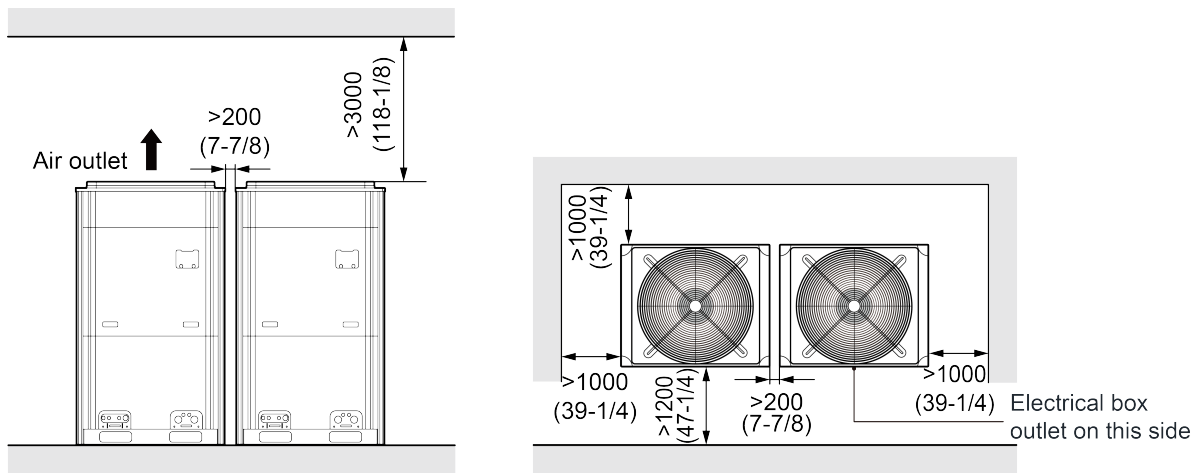

Fig.3.2.2

3.2.1.3 Space dimension for three-module unit

Unit: mm(inch)

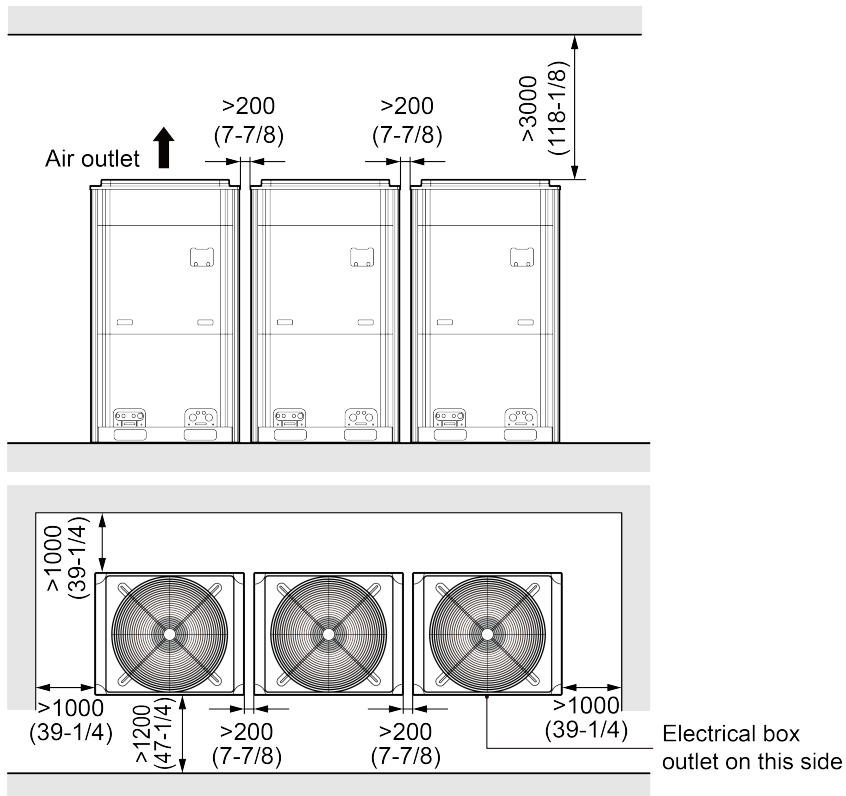

Fig.3.2.3

3.2.2 Space requirement for the top of outdoor unit

When there is wall (or similar obstruction) above the unit, keep the distance between the unit top and the wall at least 3000mm(118-1/8inch) or above. When the unit is located in a totally open space with no obstructions in four directions, keep the distance between the unit top and wall at least 1500mm(59inch) or above (See Fig.3.2.4). When space is limited within 1500mm(59inch) or the unit is not set in an open space, air outlet pipe is required to be installed in order to keep good ventilation (See Fig.3.2.5).

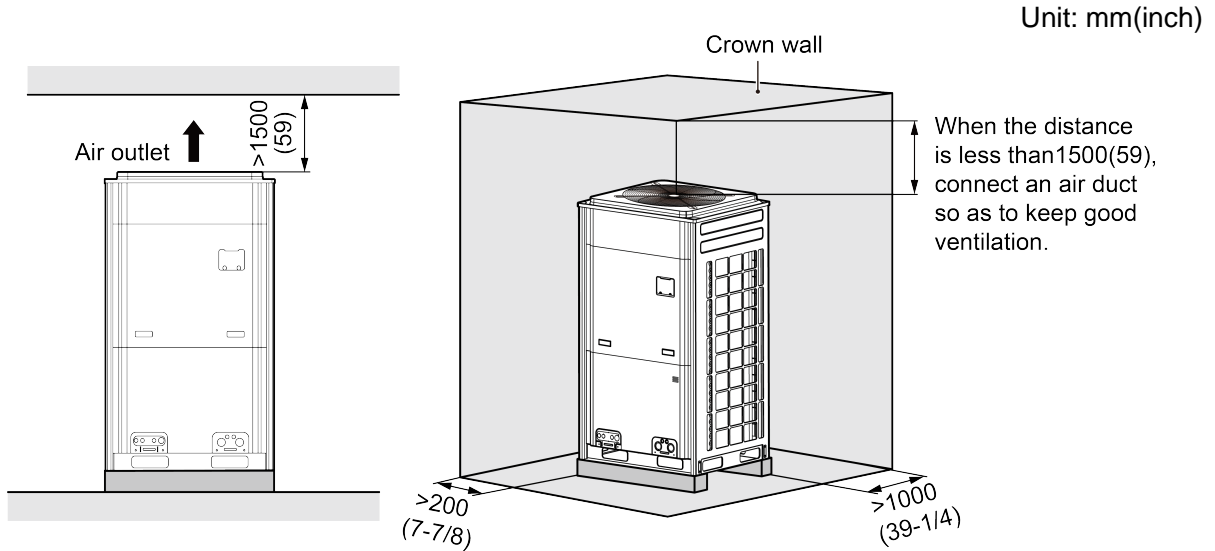

Fig.3.2.4

Fig.3.2.5

3.2.3 Space dimension for multiple-module unit

For keeping good ventilation, make sure there is no obstruction above the unit.

When the unit is located at a half-open space (front and left/right side is open), install the unit as per the same or opposite direction.

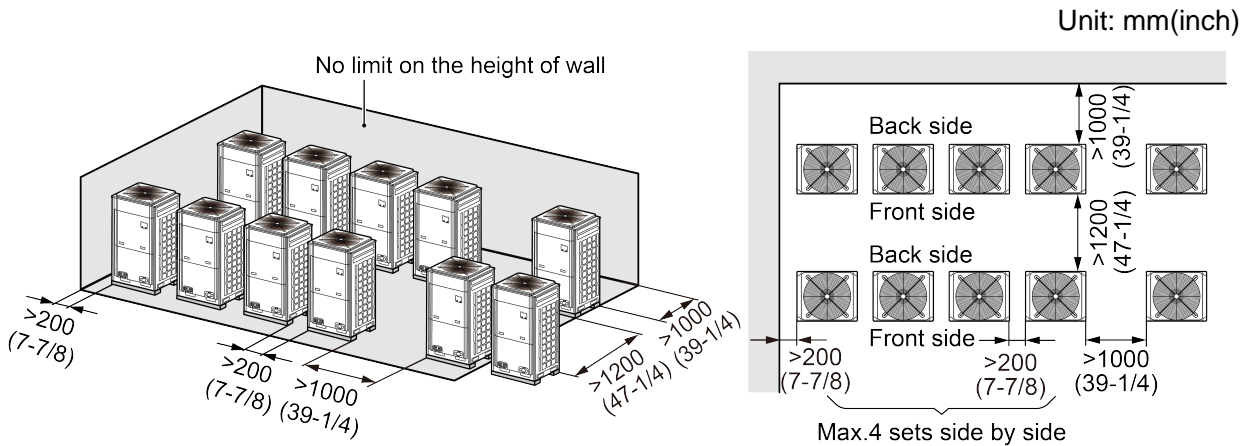

Fig.3.2.6

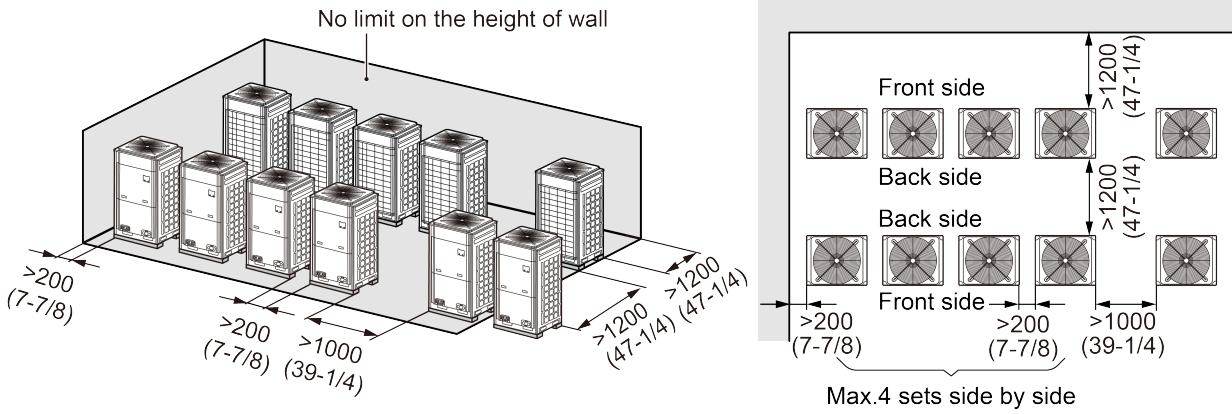

Fig.3.2.7

3.2.4 Considering the seasonal wind in outdoor unit installation

Anti-monsoon installation requirement for unit not connecting exhaust duct

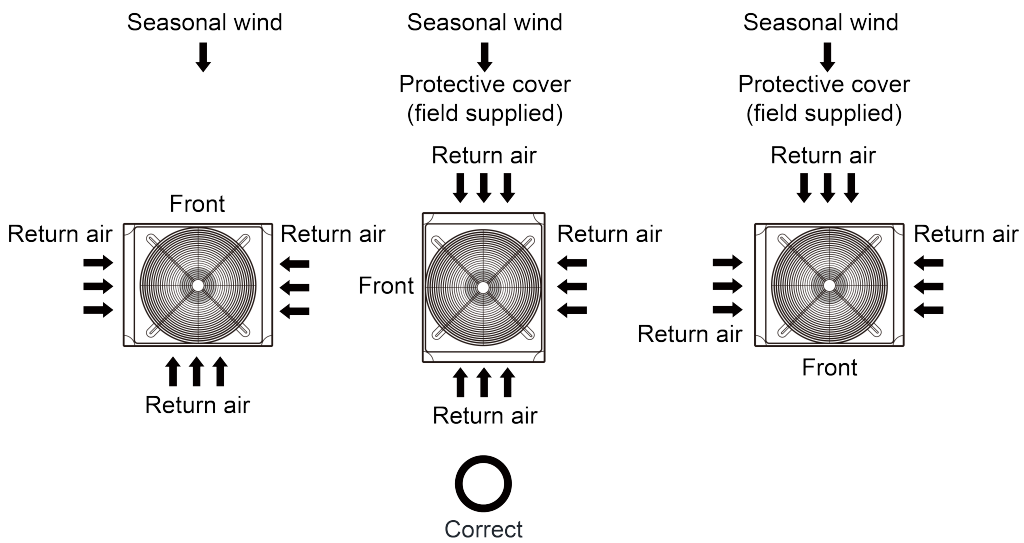

Fig.3.2.8

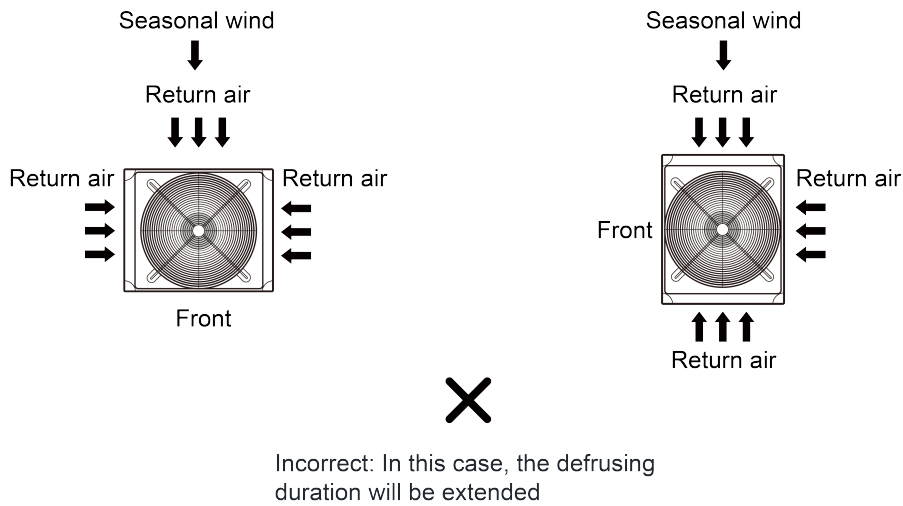

Fig.3.2.9

Anti-monsoon installation requirement for unit connecting exhaust duct

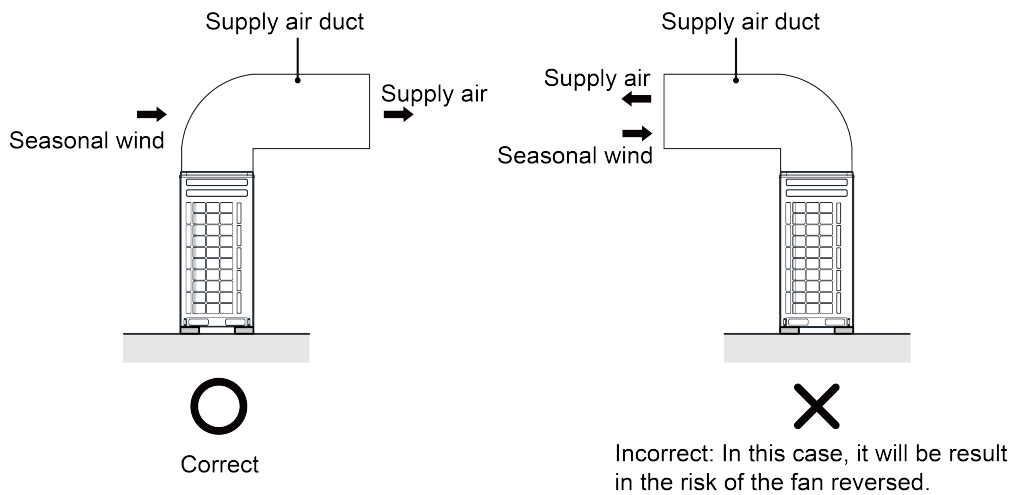

Fig.3.2.10

3.2.5 Considering snow in outdoor unit installation

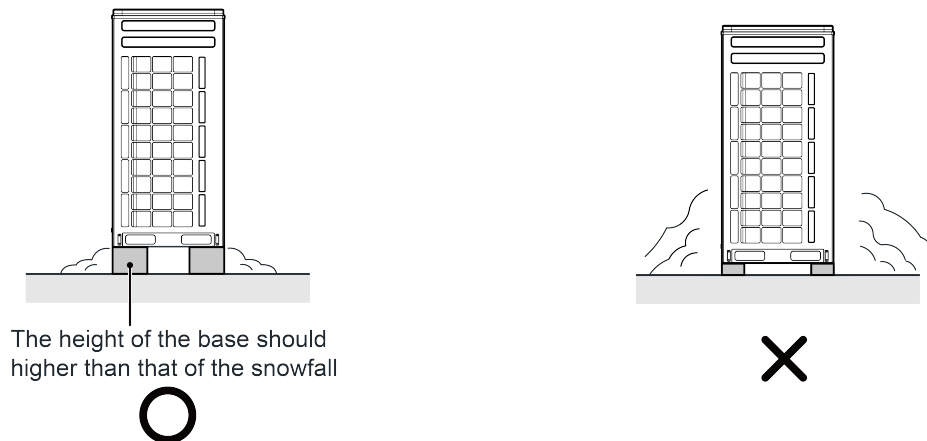

Fig.3.2.11

3.3 Piping Work Requirements

There should be no fall among outdoor modules. Refer to the table below for piping work requirements.

R410A Refrigerant System		
Outer Diameter mm(inch)	Wall Thickness mm(inch)	Type
Φ6.35(1/4)	≥0.8(1/32)	O
Φ9.52(3/8)	≥0.8(1/32)	O
Φ12.7(1/2)	≥0.8(1/32)	O
Φ15.9(5/8)	≥1.0(3/76)	O
Φ19.05(3/4)	≥1.0(3/76)	1/2H
Φ22.2(7/8)	≥1.2(1/21)	1/2H
Φ28.6(1-1/8)	≥1.2(1/21)	1/2H
Φ34.9(1-3/8)	≥1.3(2/39)	1/2H
Φ41.3(1-5/8)	≥1.5(1/17)	1/2H

4 Installation Instruction

4.1 ODU Foundation

The concrete foundation of the ODU must be strong enough. Ensure that the drainage is smooth and that the ground drainage or floor drainage is not affected.

Requirements on the concrete foundation are as follows:

- A. The concrete foundation must be flat and have enough rigidity and strength to undertake the unit's weight during running. The height of the foundation is 200 mm(7-7/8 inch) to 300 mm(11-13/16 inch), which is determined based on the size of the unit.
- B. Build a drainage ditch around the foundation to discharge the condensate water.
- C. If the air conditioner is installed on the roof, check the intensity of the building and take waterproof measures.
- D. If a u-steel foundation is adopted, the structure must be designed with sufficient rigidity and strength.

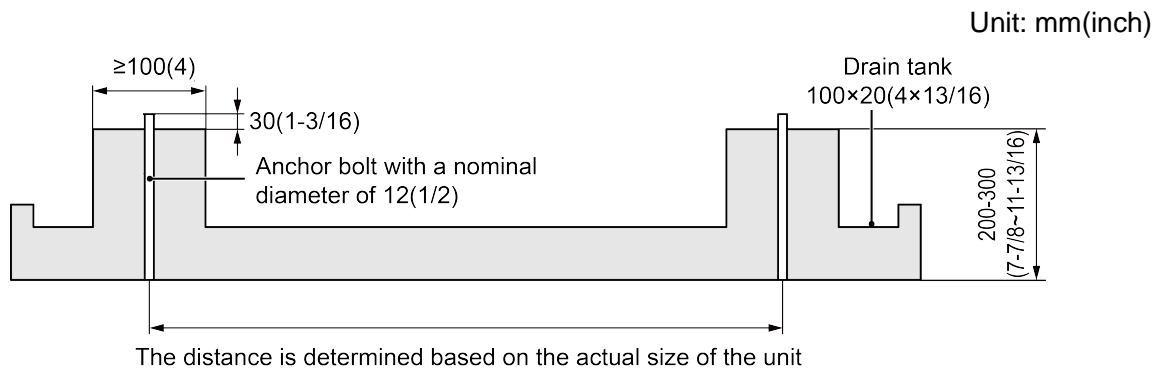

Fig.4.1

4.2 Physical Dimension of the Outdoor Unit and Mounting Hole

Outline and Physical Dimension of GMV-72WM/B-U(U).

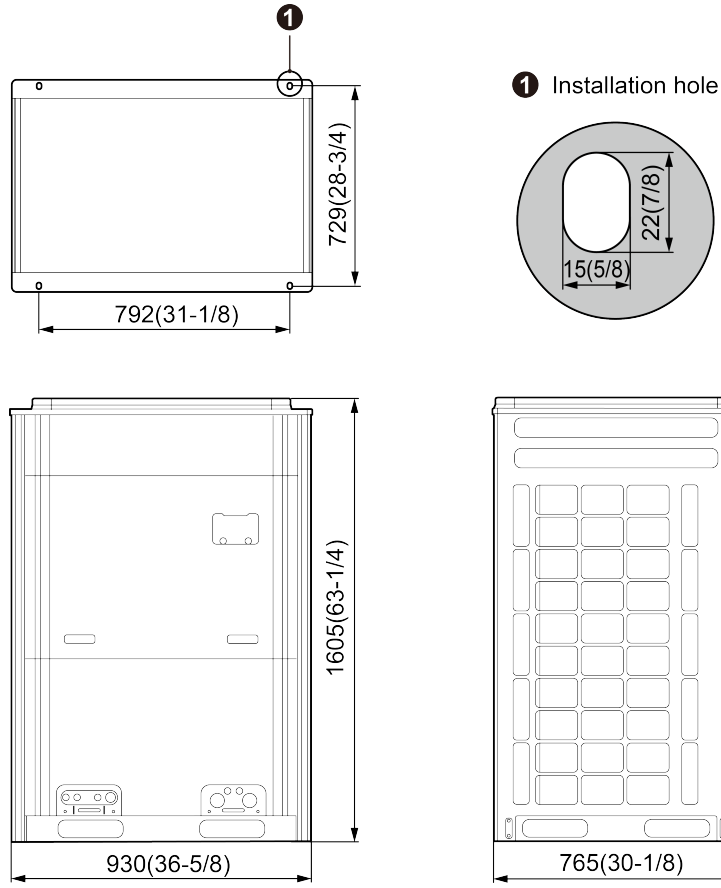

Fig.4.2.1

Outline and Physical Dimension of GMV-96WM/B-U(U) and GMV-120WM/B-U(U).

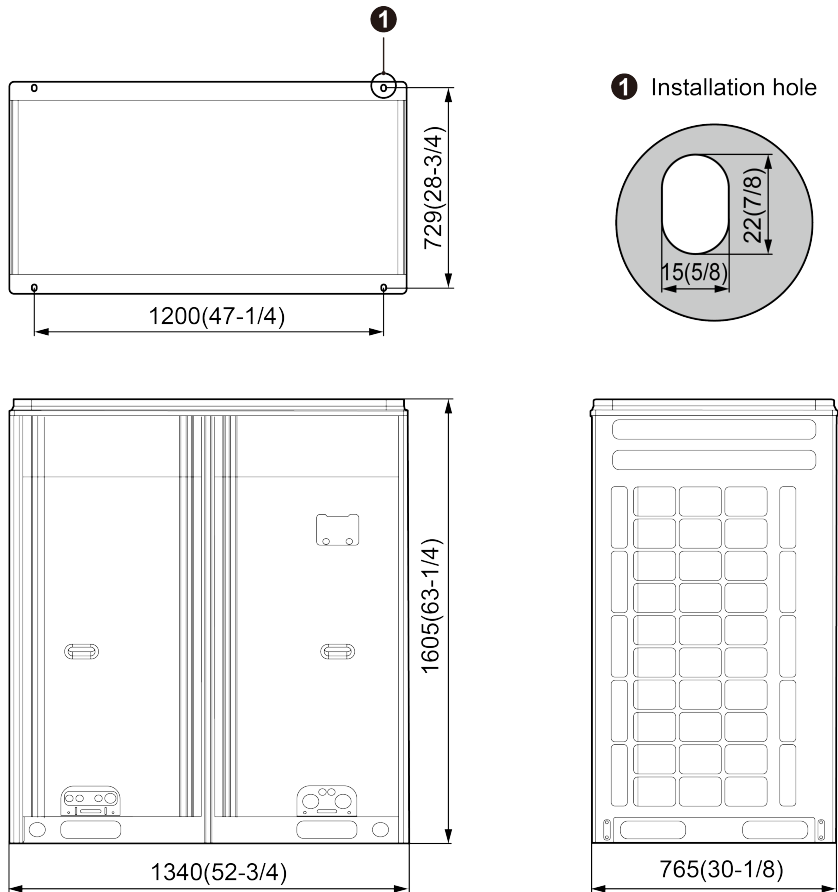

Fig.4.2.2

4.3 Connection Pipe

4.3.1 Schematic Diagram of Piping Connection

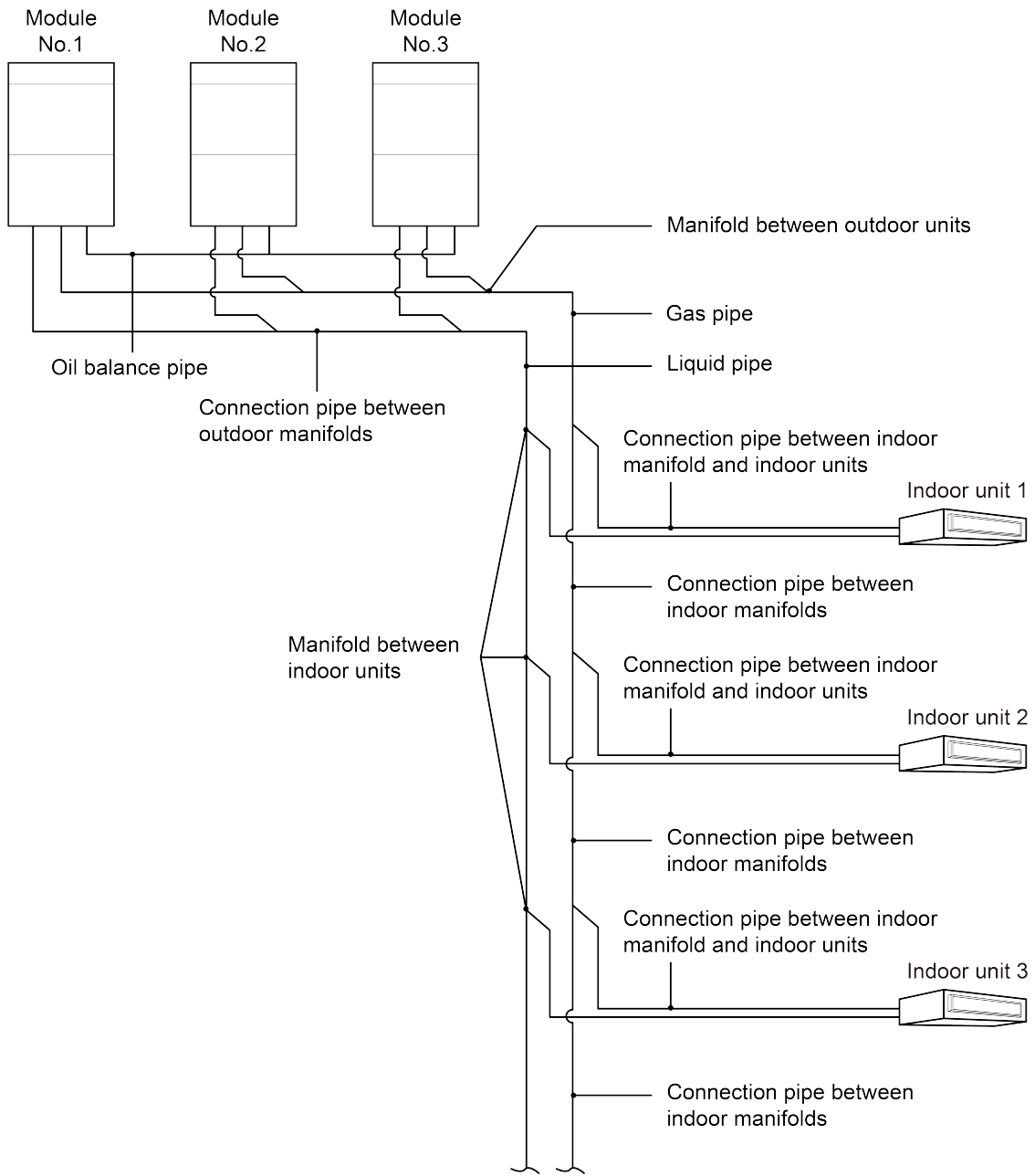

Fig.4.3.1

4.3.2 Schematic Diagram of Piping Sequence

GMV-72WM/B-U(U)

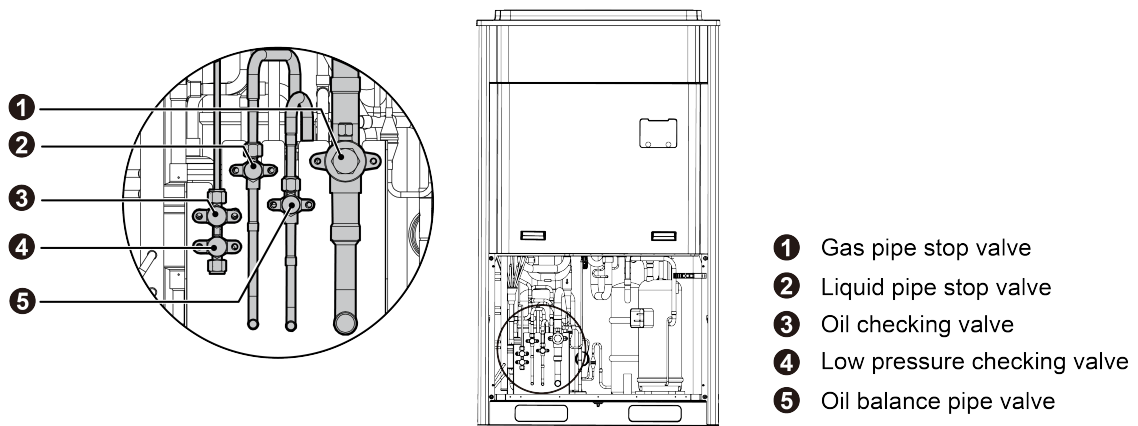

Fig.4.3.2

GMV-96WM/B-U(U) and GMV-120WM/B-U(U).

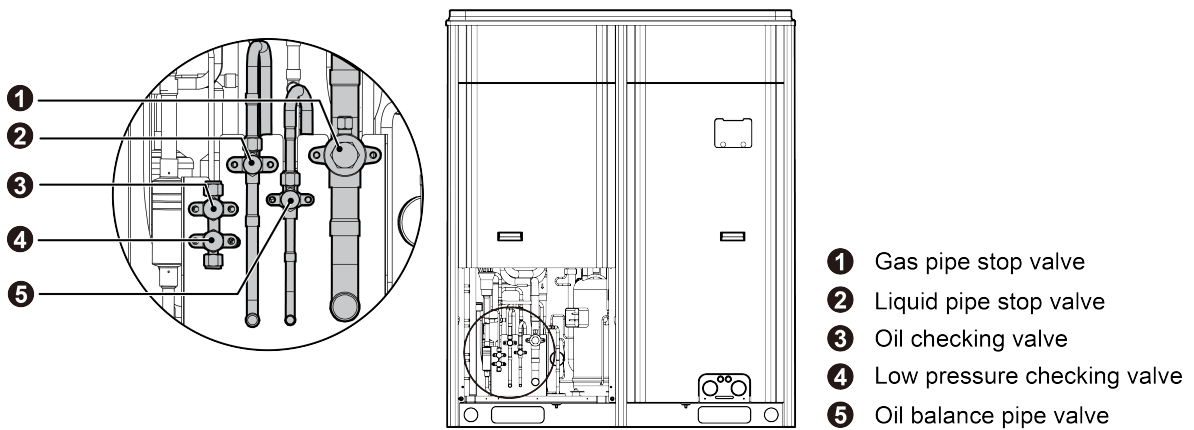

Fig.4.3.3

4.3.3 Allowable pipe length and drop height among indoor and outdoor units

Y type branch joint is adopted to connect indoor and outdoor units. Connecting method is shown in the figure below.

Remark: Equivalent length of one Y-type manifold is about 0.5m(1-3/4ft.).

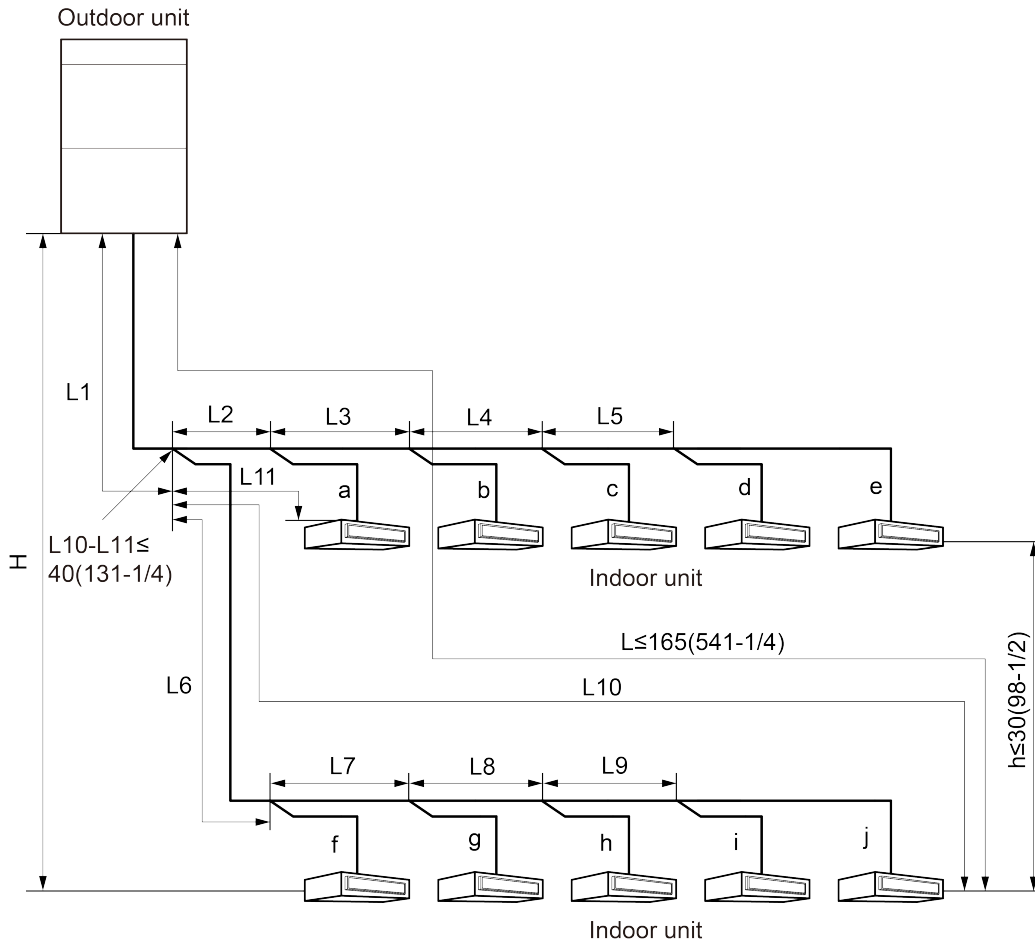

Fig.4.3.4

L10: Length from the first branch to the farthest IDU;
 L11: Length from the first branch to the nearest IDU;
 Equivalent length of branch of IDU is 0.5m(1-3/4inch).

R410A Refrigerant System		Allowable Value m(ft.)	Fitting Pipe
Total length (actual length) of fitting pipe		≤1000(3280-3/4)	L1+L2+L3+L4+...+L9+a+b+...+i+j
Length of farthest fitting pipe m(ft.)	Actual length	≤165(541-1/4)	L1+L6+L7+L8+L9+j
	Equivalent length	≤190(623-1/4)	
Difference between the pipe length from the first branch of IDU to the farthest IDU and the pipe length from the first branch of IDU to the nearest IDU		≤40(131-1/4)	L10-L11
Equivalent length from the first branch to the furthest piping (1)		≤40(131-1/4)	L6+L7+L8+L9+j
Height difference between outdoor unit and indoor unit	Outdoor unit at upper	≤90(295-1/4)	—
	Outdoor unit at lower	≤90(295-1/4)	—
Height difference between indoor units		≤30(98-1/2)	—
Maximum length of Main pipe (2)		<90(295-1/4)	L1
From IDU to its nearest branch (3)		≤40(131-1/4)	a,b,c,d,e,f,g,h,i,j

NOTICE

(1) Normally, the pipe length from the first branch of IDU to the farthest IDU is 40m(131-1/4ft.). Under the following conditions, the length can reach 90m(295-1/4ft.).

- 1) Actual length of pipe in total:
 $L1+L2x2+L3x2+L4x2+\dots+L9x2+a+b+\dots+i+j\leq 1000m(3280-3/4ft.)$
 - 2) Length between each IDU and its nearest branch a, b, c, d, e, f, g, h, i,
 $j\leq 40m(131-1/4ft.)$
 - 3) Difference between the pipe length from the first branch of IDU to the farthest IDU and the pipe length from the first branch of IDU to the nearest IDU:
 $L10-L11\leq 40m(131-1/4ft.)$
- (2) When the maximum length of the main pipe from ODU to the first branch of IDU is $\geq 90m(295-1/4ft.)$, then adjust the pipe size of the gas pipe and liquid pipe of main pipe according to the following table.

Outdoor Model	Gas pipe size mm(inch)	Liquid pipe size mm(inch)
GMV-72WM/B-U(U)	No need to enlarge pipe size	No need to enlarge pipe size
GMV-96WM/B-U(U)	No need to enlarge pipe size	$\Phi 12.7(1/2)$
GMV-120WM/B-U(U)	No need to enlarge pipe size	$\Phi 15.9(5/8)$
GMV-144WM/B-U(U)	$\Phi 34.9(1-3/8)$	$\Phi 15.9(5/8)$
GMV-168WM/B-U(U)	$\Phi 34.9(1-3/8)$	$\Phi 19.05(3/4)$
GMV-192WM/B-U(U)	$\Phi 34.9(1-3/8)$	$\Phi 19.05(3/4)$
GMV-216WM/B-U(U)	$\Phi 34.9(1-3/8)$	$\Phi 19.05(3/4)$
GMV-240WM/B-U(U)	No need to enlarge pipe size	$\Phi 19.05(3/4)$
GMV-264WM/B-U(U)	No need to enlarge pipe size	$\Phi 22.2(7/8)$
GMV-288WM/B-U(U)	No need to enlarge pipe size	$\Phi 22.2(7/8)$
GMV-312WM/B-U(U)	No need to enlarge pipe size	$\Phi 22.2(7/8)$
GMV-336WM/B-U(U)	No need to enlarge pipe size	$\Phi 22.2(7/8)$
GMV-360WM/B-U(U)	No need to enlarge pipe size	$\Phi 22.2(7/8)$

If the length between an IDU and its nearest branch is above $10m(32-7/8ft.)$, then increase the size of the liquid pipe of IDU (only for the pipe size that is $\leq 6.35mm(1/4inch)$).

4.3.4 Connection Pipe among Outdoor Modules

Unit: m(inch)

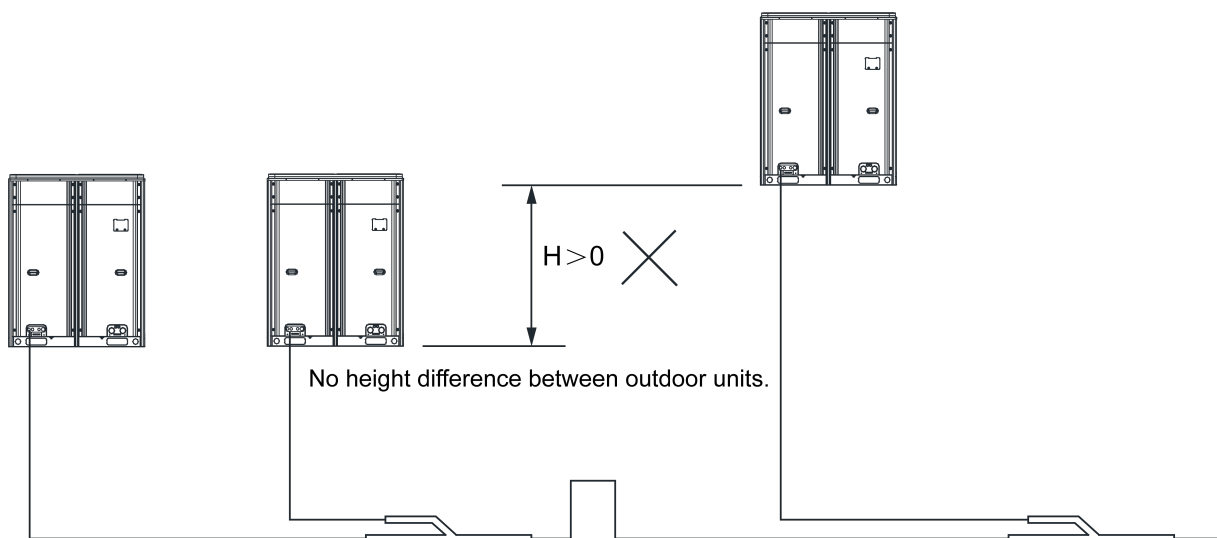

Fig.4.3.5

Unit: m(ft.)

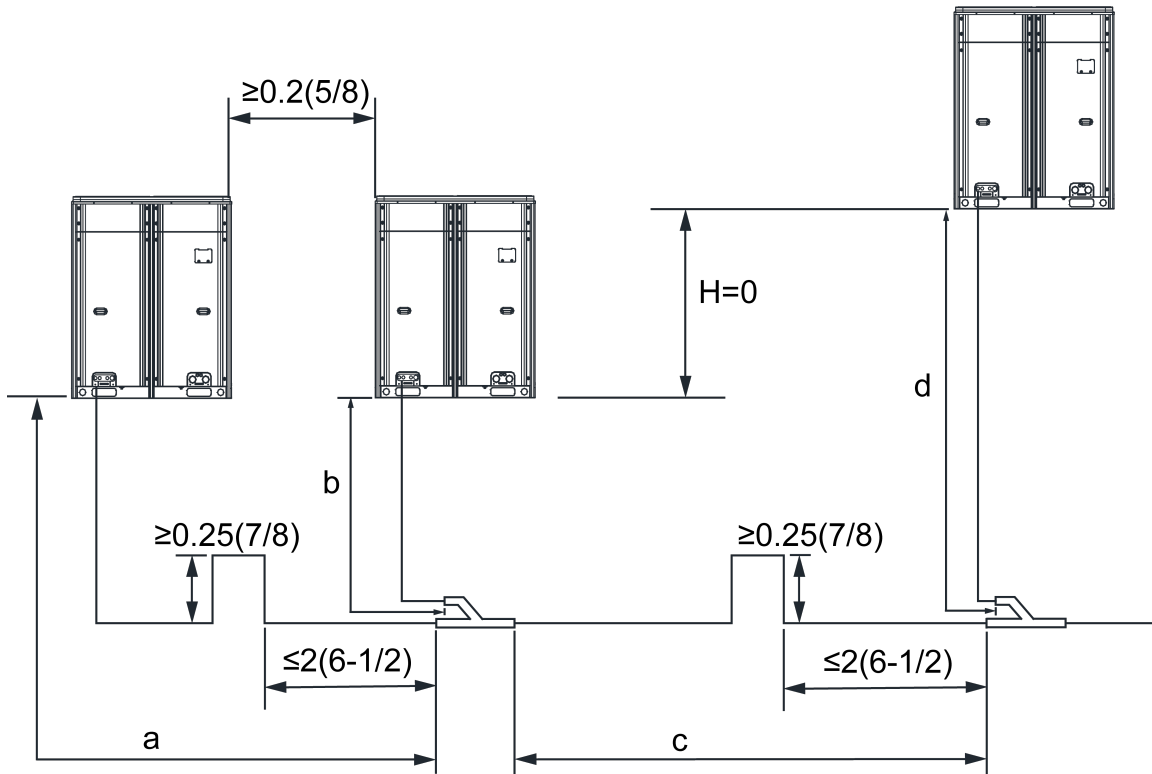

Fig.4.3.6

NOTICE When the distance between outdoor units exceeds 2m(6-1/2ft.), U-type oil trap should be added at low pressure gas pipe. $a+c \leq 10m(32-7/8ft.)$; $b+c \leq 10m(32-7/8ft.)$; $d \leq 10m(32-7/8ft.)$.

4.3.5 Fitting pipe between Outdoor Unit and the First Manifold

4.3.5.1 For single module system, pipe size (between outdoor unit and the first manifold) is determined by that of outdoor unit.

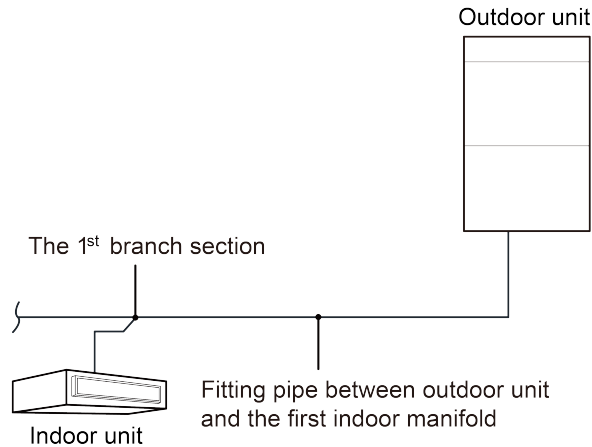

Fig.4.3.7

Pipe size of basic outdoor module is shown as follows:

Basic Module	Pipe between ODU and the first branch of IDU	
	Gas Pipe mm(inch)	Liquid Pipe mm(inch)
GMV-72WM/B-U(U)	$\Phi 19.05(3/4)$	$\Phi 9.52(3/8)$
GMV-96WM/B-U(U)	$\Phi 22.2(7/8)$	$\Phi 9.52(3/8)$
GMV-120WM/B-U(U)	$\Phi 28.6(1-1/8)$	$\Phi 12.7(1/2)$

4.3.5.2 For multi-module unit, select appropriate manifold connected to outdoor module as per the pipe size of basic module. Pipe size of basic outdoor module is shown as follows:

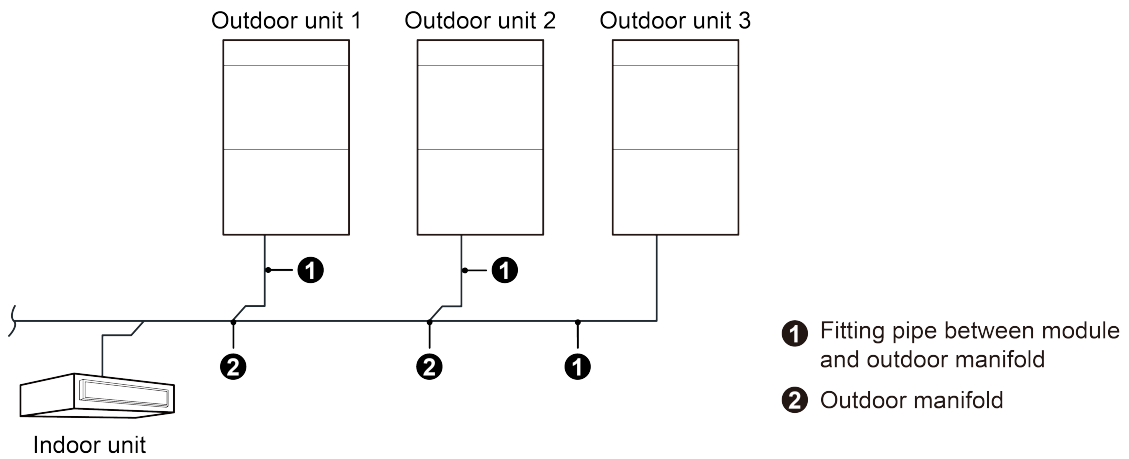

Fig.4.3.8

Basic Module	Pipe between module and branch of ODU	
	Gas Pipe mm(inch)	Liquid Pipe mm(inch)
GMV-72WM/B-U(U)	Φ19.05(3/4)	Φ9.52(3/8)
GMV-96WM/B-U(U)	Φ22.2(7/8)	Φ9.52(3/8)
GMV-120WM/B-U(U)	Φ28.6(1-1/8)	Φ12.7(1/2)

Select the branch of outdoor module

Select the branch of outdoor module	Model
	ML01/A

4.3.5.3 Fitting pipe between two manifolds from basic modules

Pipe size (between two manifolds from basic modules) is based on the total capacity of upstream modules.

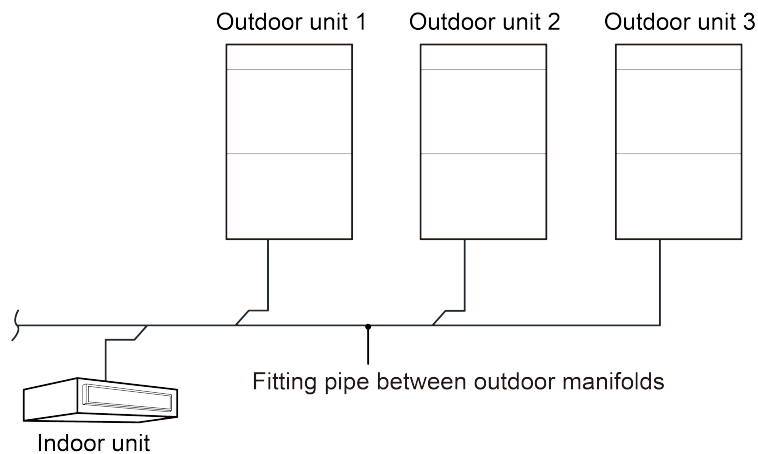

Fig.4.3.9

Total capacity of upstream modules Q(Btu/h)	Pipe size between manifolds	
	Gas pipe size mm(inch)	Liquid pipe size mm(inch)
144000	Φ28.6(1-1/8)	Φ12.7(1/2)
168000	Φ28.6(1-1/8)	Φ15.9(5/8)
192000	Φ28.6(1-1/8)	Φ15.9(5/8)
216000	Φ28.6(1-1/8)	Φ15.9(5/8)
240000	Φ34.9(1-3/8)	Φ15.9(5/8)

4.3.5.4 Fitting pipe between the first manifold from indoor unit and the end manifold from outdoor unit

Single module unit

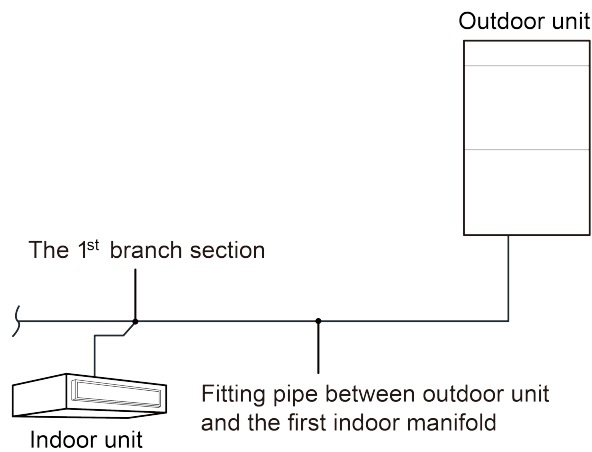

Fig.4.3.10

Basic Module	Pipe between ODU and the first branch of IDU	
	Gas Pipe mm(inch)	Liquid Pipe mm(inch)
GMV-72WM/B-U(U)	Φ19.05(3/4)	Φ9.52(3/8)
GMV-96WM/B-U(U)	Φ22.2(7/8)	Φ9.52(3/8)
GMV-120WM/B-U(U)	Φ28.6(1-1/8)	Φ12.7(1/2)

For multiple modules, the piping from ODU to the first branch of IDU is based on the total rated capacity of outdoor modules.

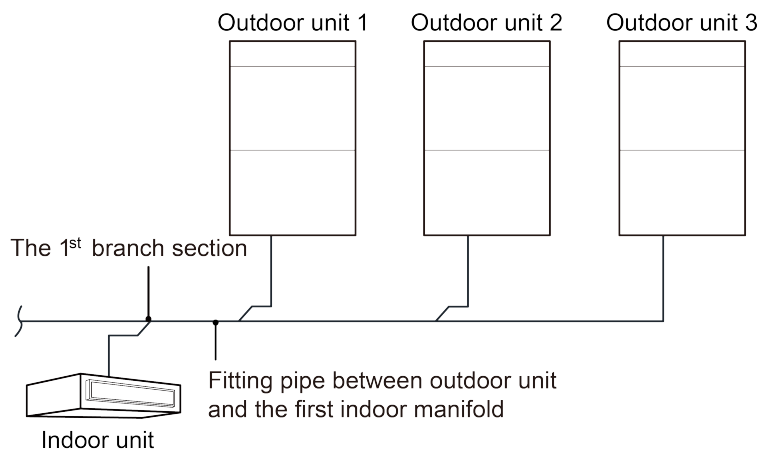

Fig.4.3.11

Total rated capacity of outdoor modules (multi-modular system)	Pipe between ODU and the first branch of IDU	
	Gas pipe size mm(inch)	Liquid pipe size mm(inch)
GMV-144WM/B-U(U)	Φ28.6(1-1/8)	Φ12.7(1/2)
GMV-168WM/B-U(U)	Φ28.6(1-1/8)	Φ15.9(5/8)
GMV-192WM/B-U(U)	Φ28.6(1-1/8)	Φ15.9(5/8)
GMV-216WM/B-U(U)	Φ28.6(1-1/8)	Φ15.9(5/8)
GMV-240WM/B-U(U)	Φ34.9(1-3/8)	Φ15.9(5/8)
GMV-264WM/B-U(U)	Φ34.9(1-3/8)	Φ19.05(3/4)
GMV-288WM/B-U(U)	Φ34.9(1-3/8)	Φ19.05(3/4)
GMV-312WM/B-U(U)	Φ34.9(1-3/8)	Φ19.05(3/4)
GMV-336WM/B-U(U)	Φ34.9(1-3/8)	Φ19.05(3/4)
GMV-360WM/B-U(U)	Φ41.3(1-5/8)	Φ19.05(3/4)

4.3.5.5 Manifold at indoor unit side

Manifold at indoor unit side can be selected as per total capacity of downstream indoor unit(s). Refer to the following table.

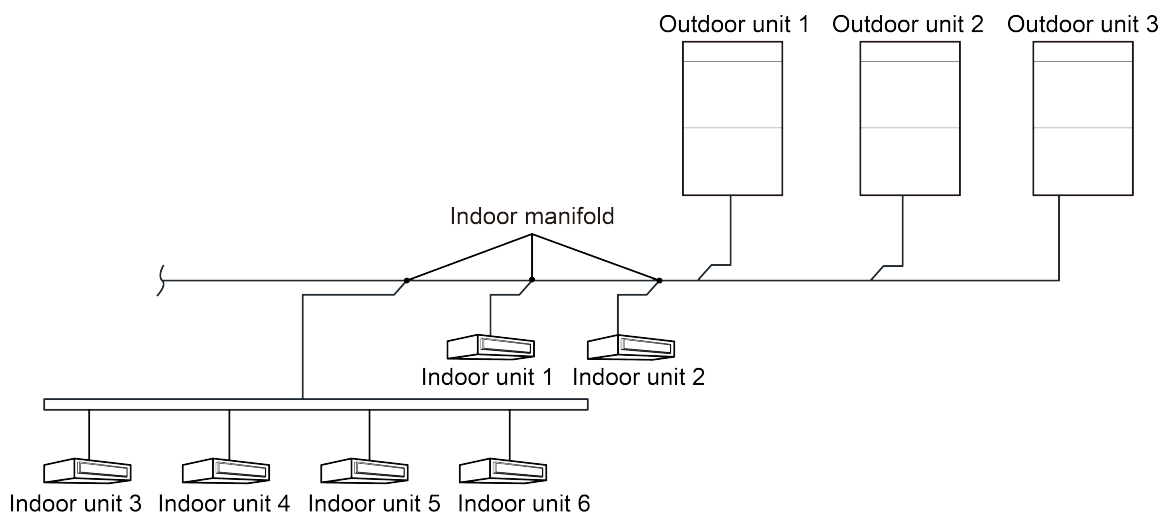

Fig.4.3.12

R410A Refrigerant System	Total capacity of downstream indoor unit(s) C (kBtu/h)	Model
Y-type Manifold	$C < 68$	FQ01A/A
	$68 \leq C \leq 102$	FQ01B/A
	$102 < C \leq 239$	FQ02/A
	$239 < C$	FQ03/A
T-type Manifold	$C \leq 136$	FQ14/H1
	$C \leq 232$	FQ18/H1
	$232 < C$	FQ18/H2

4.3.5.6 Fitting pipe between manifolds

Pipe size (between two manifolds at indoor unit side) is based on the total capacity of upstream indoor unit(s).

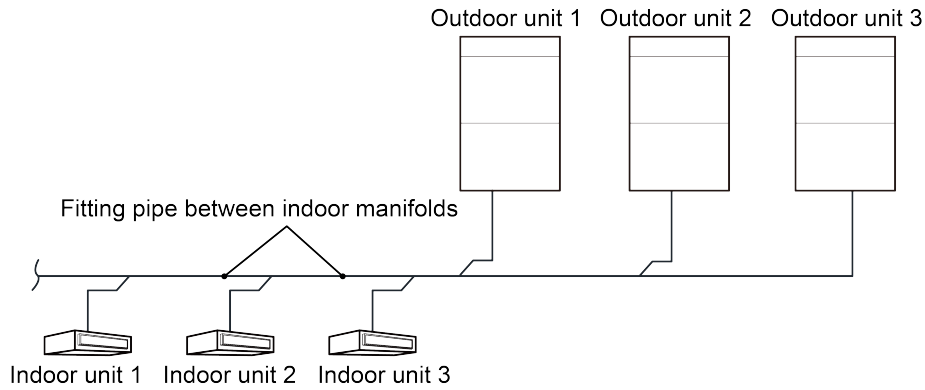

Fig.4.3.13

Total capacity of downstream indoor unit(s) C(Btu/h)	Dimension of the pipe of indoor branch	
	Gas Pipe mm(inch)	Liquid Pipe mm(inch)
$C \leq 17100$	$\Phi 12.7(1/2)$	$\Phi 6.35(1/4)$
$17100 < C \leq 48500$	$\Phi 15.9(5/8)$	$\Phi 9.52(3/8)$
$48500 < C \leq 72000$	$\Phi 19.05(3/4)$	$\Phi 9.52(3/8)$
$72000 < C \leq 96000$	$\Phi 22.2(7/8)$	$\Phi 9.52(3/8)$
$96000 < C \leq 144000$	$\Phi 28.6(1-1/8)$	$\Phi 12.7(1/2)$
$144000 < C \leq 216000$	$\Phi 28.6(1-1/8)$	$\Phi 15.9(5/8)$
$216000 < C \leq 240000$	$\Phi 34.9(1-3/8)$	$\Phi 15.9(5/8)$
$240000 < C \leq 336000$	$\Phi 34.9(1-3/8)$	$\Phi 19.05(3/4)$
$336000 < C$	$\Phi 41.3(1-5/8)$	$\Phi 19.05(3/4)$

4.3.5.7 Fitting pipe between indoor unit and manifold

Manifold should be matched with fitting pipe of indoor unit.

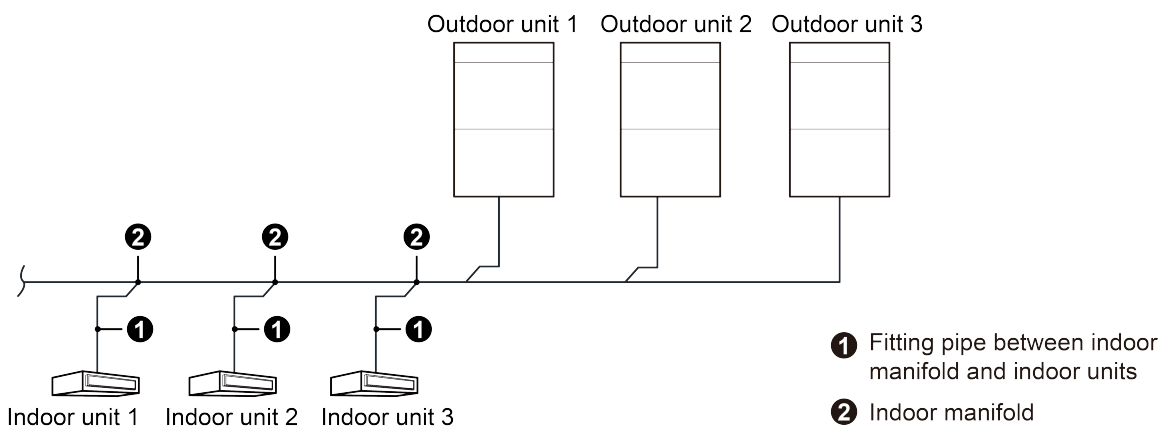

Fig.4.3.14

Rated capacity of indoor unit C(Btu/h)	Pipe between indoor branch and IDU	
	Gas Pipe mm(inch)	Liquid Pipe mm(inch)
$C \leq 9500$	$\Phi 9.52(3/8)$	$\Phi 6.35(1/4)$
$9500 < C \leq 17100$	$\Phi 12.7(1/2)$	$\Phi 6.35(1/4)$
$17100 < C \leq 48500$	$\Phi 15.9(5/8)$	$\Phi 9.52(3/8)$
$48500 < C \leq 72000$	$\Phi 19.05(3/4)$	$\Phi 9.52(3/8)$
$72000 < C$	$\Phi 22.2(7/8)$	$\Phi 9.52(3/8)$

4.4 Installation of the Connection Pipe

4.4.1 Precautions when installing the connection pipe

NOTICE Before welding the pipeline sealing cap, please make sure there's no refrigerant in pipeline. If welding it directly, it may cause unnecessary property damage or personal injury.

- (1) Before welding pipes and sealing caps, please release the residual pressure in the pipes. Direct welding may lead to property loss or personal injury.
- (2) Conform to the following principles during piping connection: connection pipeline should be as short as possible. The height difference between indoor and outdoor units should be as short as possible. Keep number of bends as little as possible. The radius of curvature should be as large as possible.
- (3) Weld the connection pipes between indoor and outdoor unit. Please strictly conform to the requirements for welding process. Rosin joints and pin holes are not allowable.
- (4) When laying the pipes, be careful not to deform them. The radius of bending parts should be more than 200mm(7-7/8inch). The pipes cannot be repeatedly bent or stretched, otherwise the material will get harden. Do not bend or stretch the pipe over three times at the same position.
- (5) Please use a torque spanner to connect union nut on the indoor unit. See Fig.4.4.1.

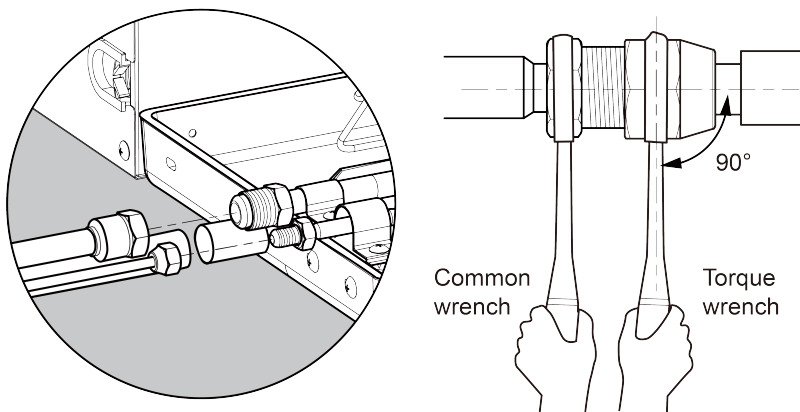

Fig.4.4.1

- 1) Align the expansion end of copper pipe with the center of threaded joint. Tighten the flare nuts with your hands.
- 2) Tighten the flare nuts with torque wrench until you hear "click" sound.
- 3) Use sponge to wrap the connecting pipe and joints without thermal insulation and tie it up with plastic tape.
- 4) A mounting support for the connection pipe is required.
- 5) The curvature degree of connection pipe should not be small, otherwise the pipe might crack. Installation personnel should use tube bender when bending the pipe.
- 6) Don't forcibly stretch the pipe joint, otherwise indoor capillary or other pipes might be damaged and lead to refrigerant leakage.

4.4.2 Manifold

(1) Y-type manifold, See the Fig.4.4.2 (a). T-type manifold, See the Fig.4.4.2(b).

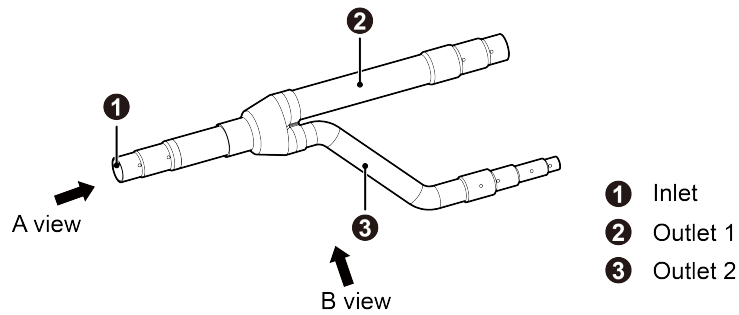

Fig. 4.4.2(a)

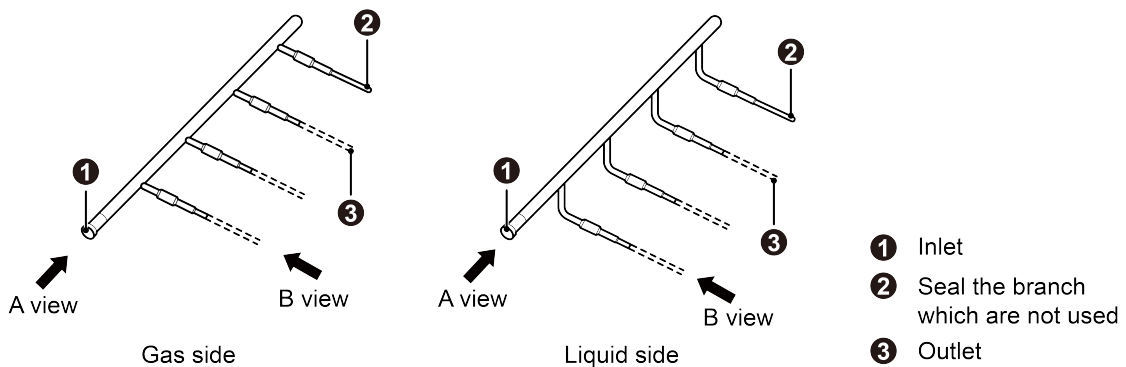

Fig.4.4.2(b)

(2) Manifold has several pipe sections with different pipe size, which facilitates to match with various copper pipe. Use pipe cutter to cut in the middle of the pipe section with different pipe size and deburr as well. See Fig.4.4.3.

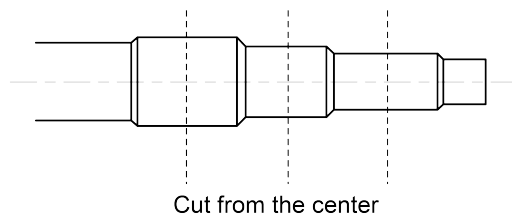

Fig.4.4.3

(3) Y-type manifold can be installed vertically or horizontally. Confirm the position and then weld the manifold pipe. See the Fig.4.4.4(a). T-type manifold must be installed horizontally with inclination, see the Fig. 4.4.4(b).

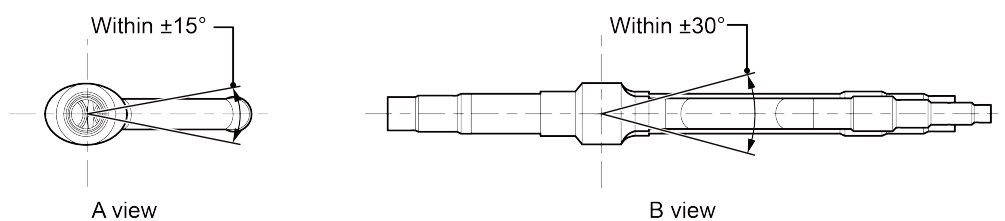

Fig.4.4.4(a)

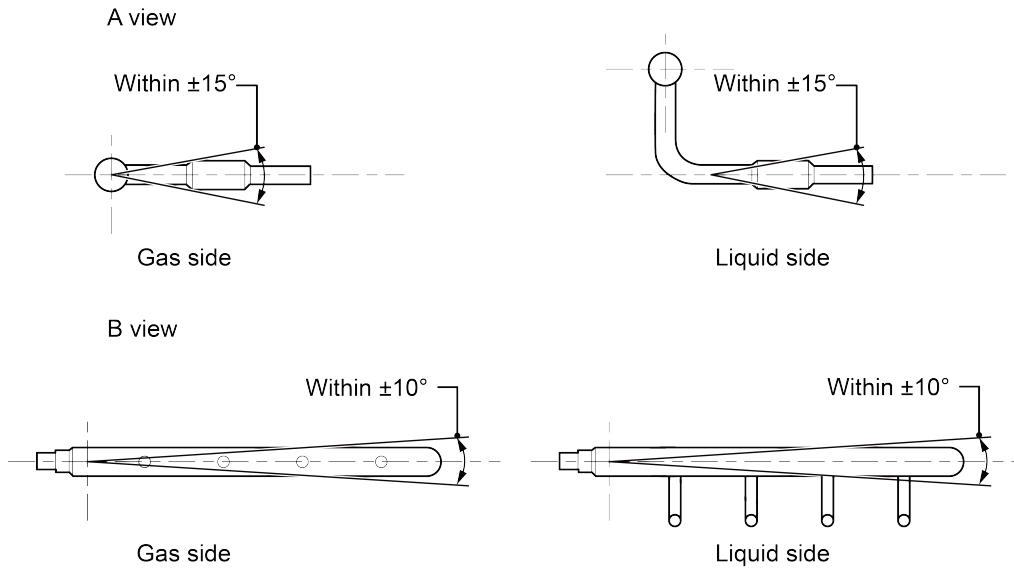

Fig.4.4.4(b)

- (4) Manifold is isolated by insulating material that can bear 120°C(248°F) or higher temperature. Manifold attached foam cannot be taken as insulating material.

4.4.3 Installation and thermal insulation for pipeline

- (1) For multi VRF system, every copper pipe should be labelled so as to avoid misconnection.
- (2) Manifolds can be laid in the following ways:

The length of a straight pipe between two manifolds cannot be less than 500 mm (19-11/16inch). The length of a straight pipe before the main pipe port of the manifold cannot be less than 500mm (19-11/16inch). The length of a straight pipe between the branch of the manifold and the IDU cannot be less than 500mm(19-11/16inch). See Fig.4.4.5.

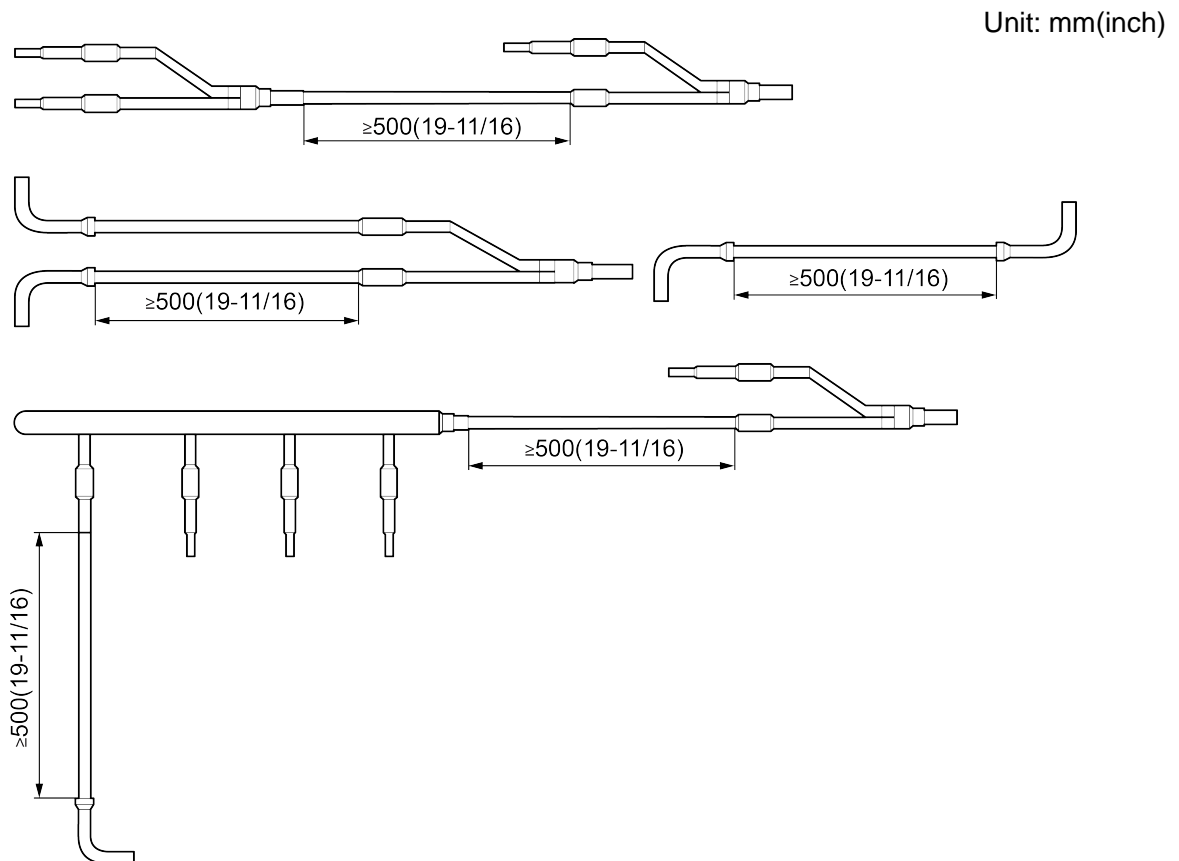

Fig.4.4.5

(3) There must be three fixing point for both horizontal and vertical installation of the Y-type manifold. See Fig.4.4.6.

Fixing point 1: 100mm(4inch) on the main inlet manifold from the welding point

Fixing point 2: 200mm(7-7/8inch) on the main branched pipe from the welding point

Fixing point 3: 250mm(9-5/6inch) on the branched pipe from the welding point

Unit: mm(inch)

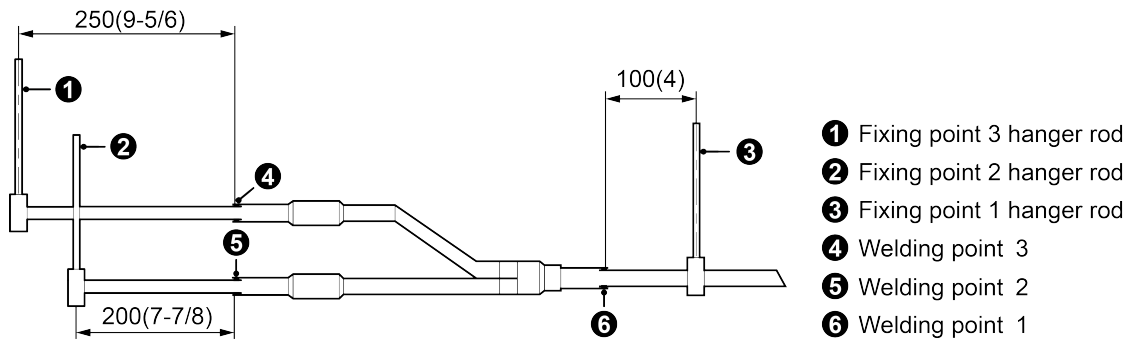

Fig.4.4.6

(4) Suspend the header to the ceiling, and be sure to install the T-type manifold so that the outlet pipes are horizontal at the lower side. See Fig.4.4.7.

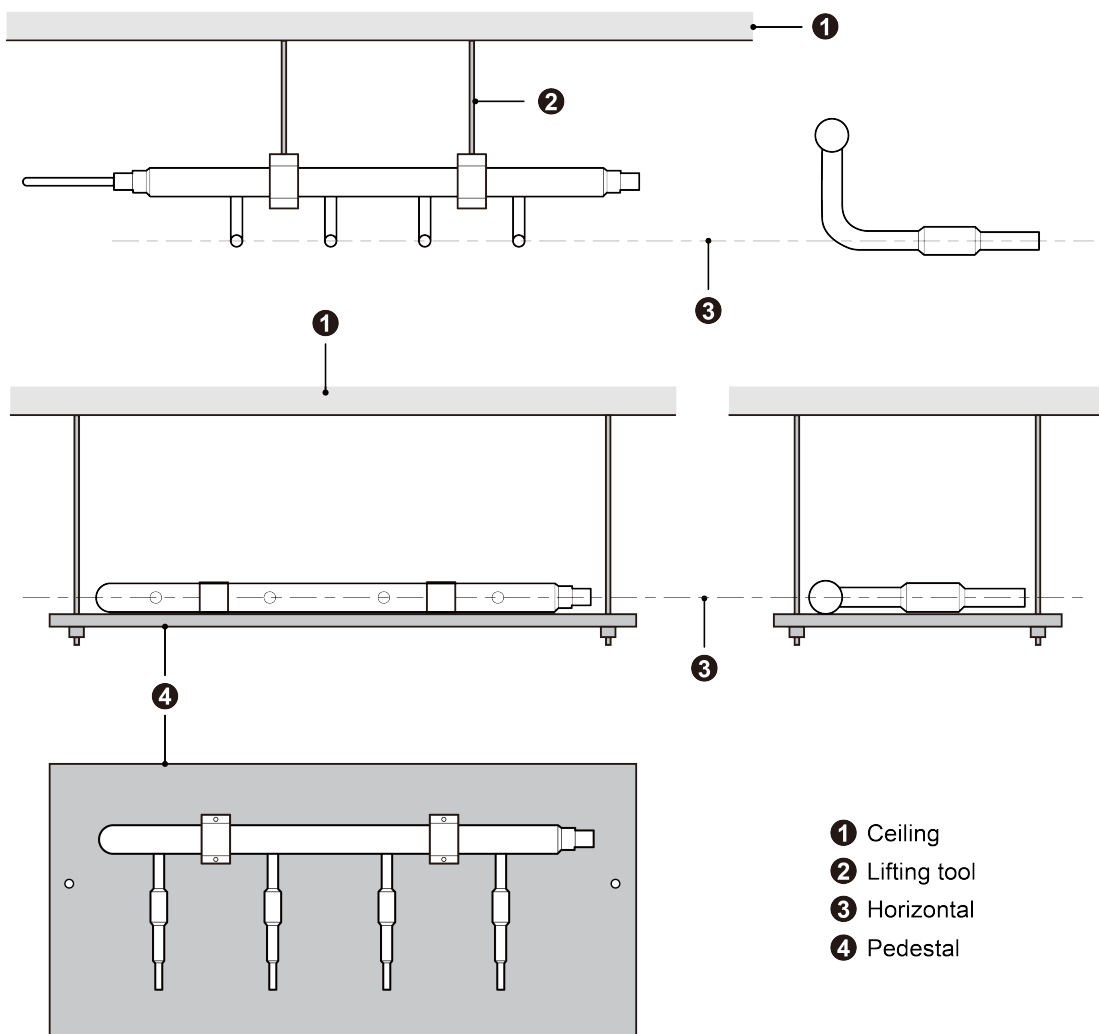

Fig.4.4.7

(5) Thermal insulation for pipeline

- 1) To avoid condensate or water leakage on connecting pipe, the gas pipe and liquid pipe must be wrapped with thermal insulating material and adhesive pipe for insulation from the air.
- 2) For heat pump unit, liquid pipe should bear 70°C(158°F) or above, and gas pipe should bear 120°C(248°F) or above. For cooling only unit, both liquid pipe and gas pipe should bear 70°C(158°F) or above. Example: Polyethylene foam can bear 120°C(248°F) above and foaming polyethylene can bear 100°C(212°F) above.
- 3) Joints at indoor and outdoor units should be wrapped with insulating material and leave no clearance between pipe and wall. See Fig.4.4.8.

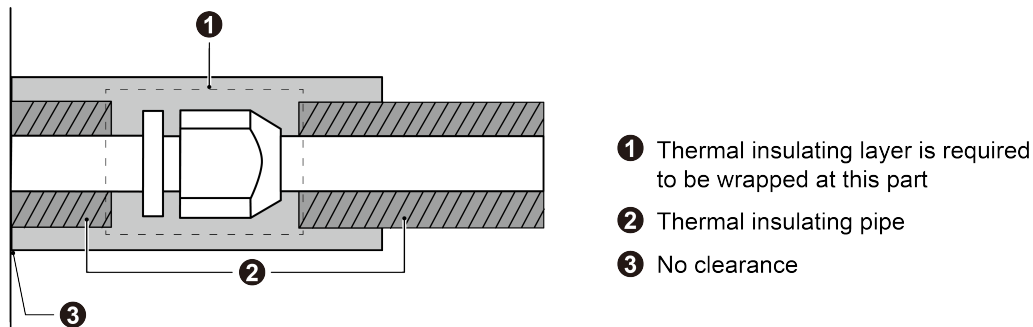

Fig.4.4.8

- 4) Manifold attached foam can not be taken as insulating material.
- 5) When wrapping the tape, the later circle should cover half of the former one. Don't wrap the tape so tightly, otherwise the insulation effect will be weakened.
- 6) After wrapping the pipe, adopt sealing material to completely fill the hole so as to prevent wind and rain from entering the room.

4.4.4 Support and protection for pipeline

- (1) Support should be made for hanging connection pipe. Distance between each support can not be over 1m(39-3/8inch).
- (2) Protection towards accidental damage should be made for outdoor pipeline. When the pipeline exceeds 1m(39-3/8inch), a pin. board should be added for protection.

4.5 Air Purging and Refrigerant Charge

4.5.1 Air purging

- (1) Confirm outdoor liquid and gas valves are closed. Air purging from the nozzle located on liquid and gas valves by vacuum pump. See Fig.4.5.1.
- (2) When there are more than 2 outdoor units, air purging from the nozzle located on the oil balance valve. Confirm outdoor oil balance valves are closed. See Fig.4.5.2.

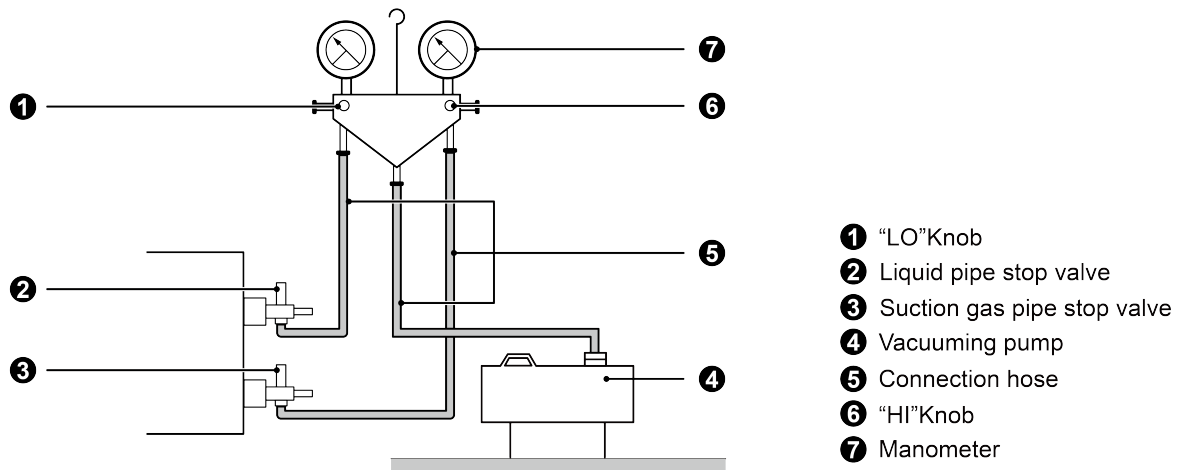

Fig.4.5.1

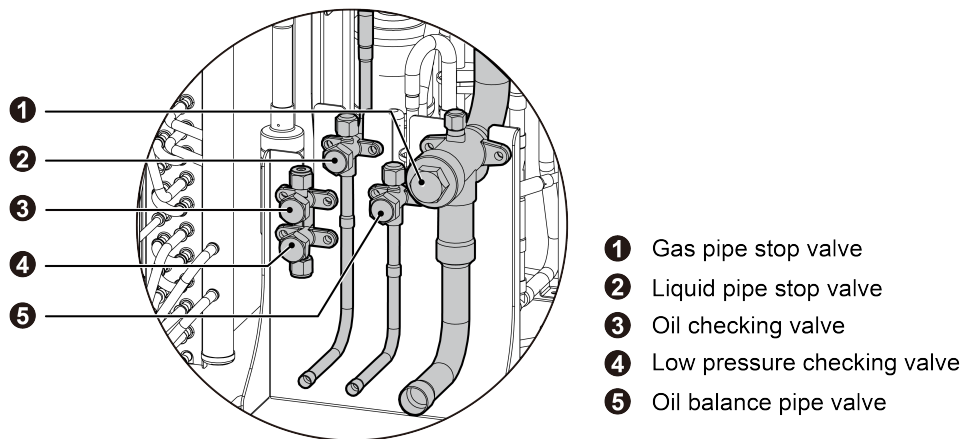

Fig.4.5.2

4.5.2 Additional refrigerant charging

Outdoor unit has been charged refrigerant before delivery.

Charge additional refrigerant for field-installed connecting pipe. If the pipeline is longer than 1m(39-3/8inch), please refer to the following table for charging amount of refrigerant (Liquid pipe prevails).

How much additional refrigerant should be charged.

Total refrigerant charging amount $R = \text{Pipeline charging amount } A + \sum \text{charging amount } B \text{ of every module.}$

(1) Pipeline charging amount

Added refrigerant quantity A for piping = $\sum \text{Liquid pipe length} \times \text{Added refrigerant quantity for each meter(inch) of liquid pipe.}$

	Diameter of liquid pipe							
	mm(inch)							
	28.6(1-1/8)	25.4(1)	22.2(7/8)	19.05(3/4)	15.9(5/8)	12.7(1/2)	9.52(3/8)	6.35(1/4)
kg/m	0.680	0.520	0.350	0.250	0.170	0.110	0.054	0.022
OZ/inch	0.61	0.47	0.31	0.22	0.15	0.10	0.05	0.02

(2) Σ Refrigerant charging amount B of every module.

Refrigerant charging amount B of every module kg(Pounds)		Rated Capacity(kBtu/h)		
IDU/ODU rated capacity collocation ratio C	Quantity of included IDUs(N)	72	96	120
50% \leq C \leq 90%	N<4	0	0	0
	N \geq 4	0.5(1.1)	0.5(1.1)	0.5(1.1)
90%<C \leq 105%	N<4	1(2.2)	1(2.2)	1.5(3.3)
	8>N \geq 4	2(4.4)	2(4.4)	3(6.6)
	N \geq 8	4(8.8)	3.5(7.7)	4(8.8)
105%<C \leq 135%	N<4	2(4.4)	2(4.4)	2.5(5.5)
	8>N \geq 4	4(8.8)	3.5(7.7)	4(8.8)
	N \geq 8	4.5(9.9)	4.5(9.9)	5(11.0)

NOTICE

- (1) IDU/ODU rated capacity collocation ratio C = Sum of rated cooling capacity of indoor unit / Sum of rated cooling capacity of outdoor unit.
- (2) If all of the indoor units are fresh air indoor units, the quantity of refrigerant added to each module is 0kg.
- (3) If outdoor air processor is connected with normal VRF indoor unit, adopt the perfusion method for normal indoor unit for perfusion.

For example 1:

The ODU is composed of 3 modules: 72kBtu/h, 120 kBtu/h and 120 kBtu/h. The IDUs are made up of 7sets of 48 kBtu/h.

IDU/ODU rated capacity collocation ratio C= $48 \times 7 / (72 + 120 + 120) = 108\%$. The quantity of included IDUs is more than 4 sets. Please refer to the above table.

Refrigerant charging amount B for 72kBtu/h module is 4.0kg(8.8pounds).

Refrigerant charging amount B for 120 kBtu/h module is 4.0kg(8.8pounds).

Refrigerant charging amount B for 120 kBtu/h module is 4.0kg(8.8pounds).

So, Σ Refrigerant charging amount B of every module = $4.0 + 4.0 + 4.0 = 12\text{kg}$ (8.8+8.8+8.8 =26.4pounds).

Suppose the Pipeline charging amount A = Σ Liquid pipe length \times refrigerant charging amount of every 1m (or 1inch) liquid pipe = 25kg (55.1 pounds)

Total refrigerant charging amount R = $25 + 12 = 37\text{kg}$ (55.1+26.4=81.5pounds).

For example 2:

Outdoor unit is a 72kBtu/h module and the indoor unit is a 72kBtu/h fresh air unit. The quantity (B) of refrigerant added to this module is 0kg (0pounds).

So, ΣB (Quantity of refrigerant added to each module) = 0kg (0pounds).

Suppose that A (Quantity of refrigerant added to connection pipe) = Σ Length of liquid pipe \times Quantity of refrigerant added to liquid pipe per meter) = 5kg (11pounds).

R (Quantity of added refrigerant in total) = $5 + 0 = 5\text{kg}$ (11+0=11pounds).

Modular combination of outdoor unit subjects to combinations that is currently available.

After confirming that there is no leakage from the system, when the compressor is not in operation, charge additional R410A with specified amount to the unit through the filling opening of the

liquid pipe valve of the outdoor unit. If required additional refrigerant cannot be quickly filled for increase of pressure in the pipe, set the unit at cooling startup and then fill the refrigerant from gas valve of outdoor unit. If ambient temperature is low, the unit can't be set to cooling mode but heating mode.

4.5.3 Precautions on Refrigerant Leakage

- (1) Personnel related to air conditioning engineering design and installation operators must abide by the safety requirement for preventing refrigerant leakage specified in local laws and regulations.
- (2) The units adopt the R410A refrigerant, which is nonflammable and nontoxic. However, the space for refrigerant leakage must be sufficient to ensure that the refrigerant concentration does not exceed that specified in the safety requirement; otherwise, people involved can be stifled by the refrigerant. For example the maximum allowed concentration level of refrigerant to a humanly space for R410A according to the appropriate European Standard is limited to 0.44 kg/m^3 .

The maximum amount of refrigerant (kg) in the system = The volume of the room (m^3) \times The maximum allowed concentration level of refrigerant (kg/m^3)

Total amount of refrigerant (kg) in the system = Total additional charging amount (kg) + Amount of refrigerant (kg) which is charged before leaving the factory (for the system consisting of multiple modules in parallel, the accumulative charge quantity of modules before leaving the factory is used)

Total amount of refrigerant (kg) in the system \leq The maximum amount of refrigerant (kg) in the system

- (3) When the total amount of refrigerant in the system is more than the maximum amount of refrigerant, the cooling system should be designed again. In this case, the cooling system can also be separated into several cooling systems with small capacity, or add corresponding ventilation measures or alarming display.

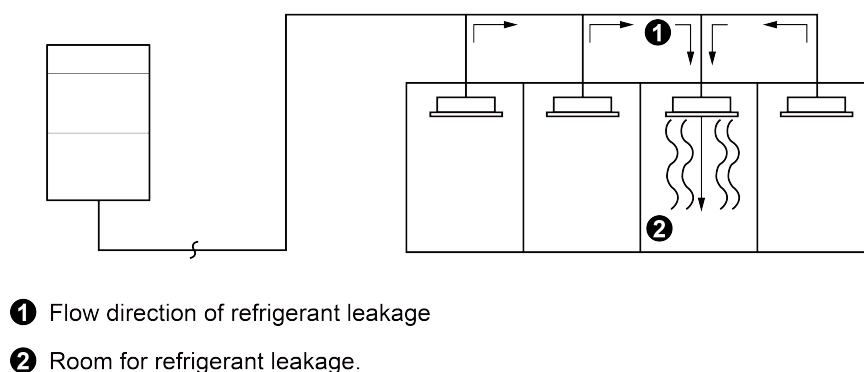

Fig.4.5.3

Since the concentration of refrigerant is greater than that of air, pay attention to the spaces where the refrigerant may residue, for example, the basement.

4.6 Electric Wiring

4.6.1 Wiring precautions

⚠ WARNING
(1) Wiring should conform to national rules. All the parts, materials, electric work should be in accordance with local codes.
(2) Rated voltage and exclusive power supply should be used.
(3) Power cord should be fixed soundly and reliable. Never forcibly pull the power cord.
(4) Wire size of power cord should be large enough. The damaged power cord and connecting wire should be replaced by exclusive cable.
(5) All the electrical work should be performed by professional personnel as per local law, regulation and this manual.
(6) Connect the unit to the special earthing device and make sure the unit is earthed soundly.
(7) Air switch and circuit breaker is required to be set. Air switch should have both magnetic trip and thermal trip functions so as to protect the unit when short-circuit and overload happens. D-type breaker is advised to be used.
(8) Wiring diagram attached on the unit is prevailed.

4.6.2 Wiring of power cord

Every unit should have corresponding short-circuit and overload protection. And also a main switch is required to control power supply or disconnection. See Fig.4.6.1.

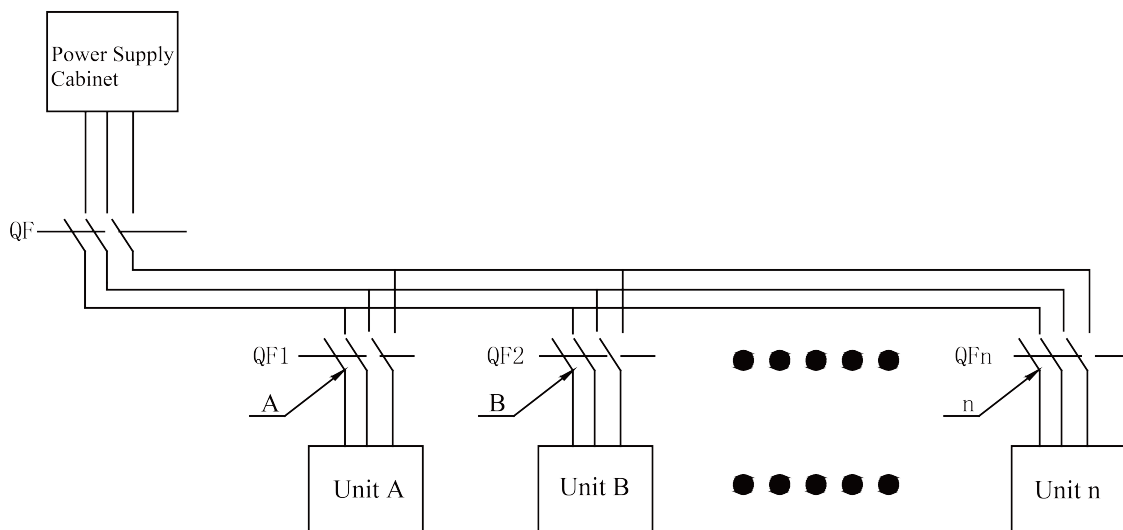

Fig.4.6.1

Refer to the following table for outdoor unit power cord specifications and circuit breakers.

Outdoor units	Power Supply	Fuse Capacity	Minimum Circuit Ampacity	Maximum Overcurrent Protection
	V/ Ph /Hz	A	A	A
GMV-72WM/B-U(U)	460V 3~ 60Hz	20	15	20
GMV-96WM/B-U(U)	460V 3~ 60Hz	25	18	25
GMV-120WM/B-U(U)	460V 3~ 60Hz	30	25	30
GMV-144WM/B-U(U)	460V 3~ 60Hz	20+20	15+15	20+20
GMV-168WM/B-U(U)	460V 3~ 60Hz	20+25	15+18	20+25
GMV-192WM/B-U(U)	460V 3~ 60Hz	25+25	18+18	25+25
GMV-216WM/B-U(U)	460V 3~ 60Hz	25+30	18+25	25+30
GMV-240WM/B-U(U)	460V 3~ 60Hz	30+30	25+25	30+30
GMV-264WM/B-U(U)	460V 3~ 60Hz	20+25+25	15+18+18	20+25+25

Outdoor units	Power Supply	Fuse Capacity	Minimum Circuit Ampacity	Maximum Overcurrent Protection
	V/ Ph /Hz	A	A	A
GMV-288WM/B-U(U)	460V 3~ 60Hz	25+25+25	18+18+18	25+25+25
GMV-312WM/B-U(U)	460V 3~ 60Hz	25+25+30	18+18+25	25+25+30
GMV-336WM/B-U(U)	460V 3~ 60Hz	25+30+30	18+25+25	25+30+30
GMV-360WM/B-U(U)	460V 3~ 60Hz	30+30+30	25+25+25	30+30+30

⚠ WARNING

- (1) Specification of circuit breaker and power cord is selected on the basis of unit's maximum power (max. current).
- (2) Specification of power cord is based on the working condition where ambient temperature is 40°C(104°F) and multi-core cable with copper conductor(working temperature is 90°C(194°F), e.g. power cable with YJV cross-linked copper, insulated G and PVC sheath) is lying on the surface of slot. If working condition is different, please adjust the specification according to national standard.
- (3) Copper-core cable must be used.
- (4) The above sectional area is suitable for a maximum distance of 15m(49-1/5ft.). If it's over 15m(49-1/5ft.), sectional area must be expanded to prevent overload current from burning the wire or causing fire hazard.
- (5) Specification of circuit breaker is based on the working condition where the ambient temperature of circuit breaker is 40°C(104°F). If working condition is different, please adjust the specification according to national standard.
- (6) The air switch should include magnetic trip function and thermal trip function so that system can be protected from short circuit and overload.
- (7) An all-pole disconnection switch having a contact separation of at least 3mm(1/8inch) in all poles should be connected in fixed wiring.

4.6.3 Connection of power cord

⚠ WARNING

- (1) Before obtaining access to terminals, all supply circuits must be disconnected.
- (2) If units are type I electrical appliances, they must be reliably grounded.
- (3) Ground resistance must be in accord with requirements of local standard.
- (4) The green-yellow wire within units are ground wire. Do not use it for other purposes. Nor should it be cut off or secured by tapping screws. Otherwise, it may cause electric shock.
- (5) Power supply at user side must have reliable ground terminal. Do not connect ground wire to the following places:
 - 1) Water pipe.
 - 2) Gas pipe.
 - 3) Drainage pipe.
 - 4) Other places that are considered by professionals as unreliable.
- (6) Power cord and communication wire should be separated, with a distance of more than 20cm(7-7/8inch). Otherwise, system's communication may not work well.

Steps of power cord connection:

- (1) Knock off the cross-through opening that's used for leading the external power cord, with the cross-through rubber ring on the opening. Then lead the cable through the opening. Connect L1, L2, L3 of power cord and ground wire separately to the positions on wiring board (for power supply) that are marked with L1, L2, L3 and the ground screw nearby.
- (2) Fasten the power cord with cable tie.
- (3) Lay the power cable and communication cable for the ODU according to the marker of external connection circuit diagram.

4.7 System Communication

4.7.1 Communication system include:

- (1) Communication among outdoor basic modules.
- (2) Communication between ODU and IDU.
- (3) Communication among IDUs.
- (4) Communication between IDU and wired controller.
- (5) Connection between IDU and light board receiver.
- (6) Communication between different refrigeration systems.
- (7) Graphics of general communication connection.

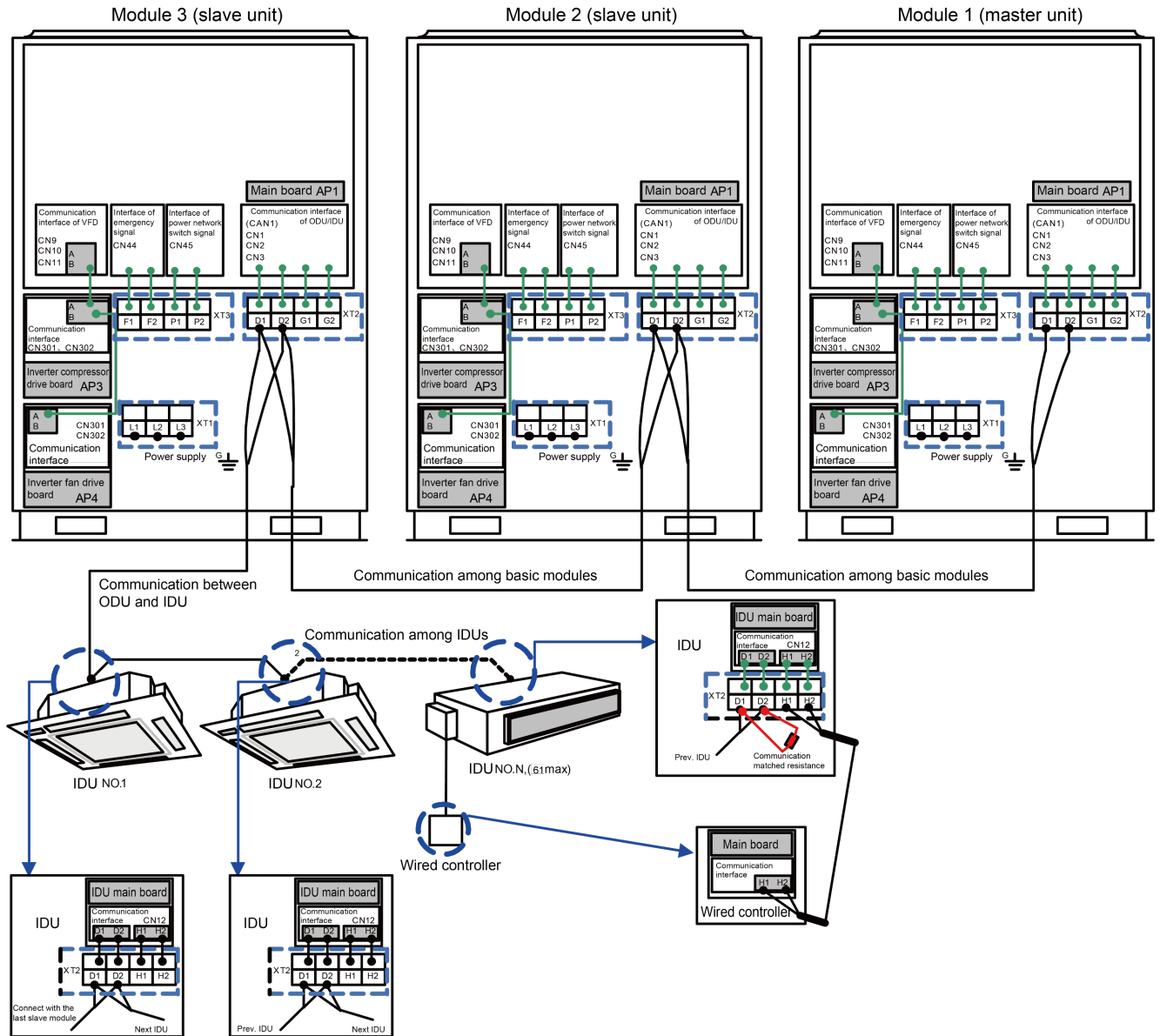

Fig.4.7.1

4.7.2 Communication mode of GMV DC Inverter Units

CAN bus mode is taken for communication between IDU and ODU and communication among IDUs.

4.7.3 Selection and connection mode of GMV5 communication material

4.7.3.1 Select communication material

NOTICE If air conditioners are installed at places where there's strong electromagnetic interference, the communication wire of IDU and wired controller must use shielded wire and the communication wire between IDU and IDU/ODU must use shielded twisted pair.

(1) Select communication wire between IDU and wired controller

Material type	Total length of communication line between IDU unit and wired controller L m(inch)	Wire size	Remarks
Light/Ordinary polyvinyl chloride sheathed cord.	$L \leq 250(820-1/4)$	2xAWG18~ 2xAWG16	<ol style="list-style-type: none"> Total length of communication line can't exceed 250m(820-1/4inch). The cord shall be Circular cord (the cores shall be twisted together). If unit is installed in places with intense magnetic field or strong interference, it is necessary to use shielded wire.

Graphic of connection between IDU and wired controller

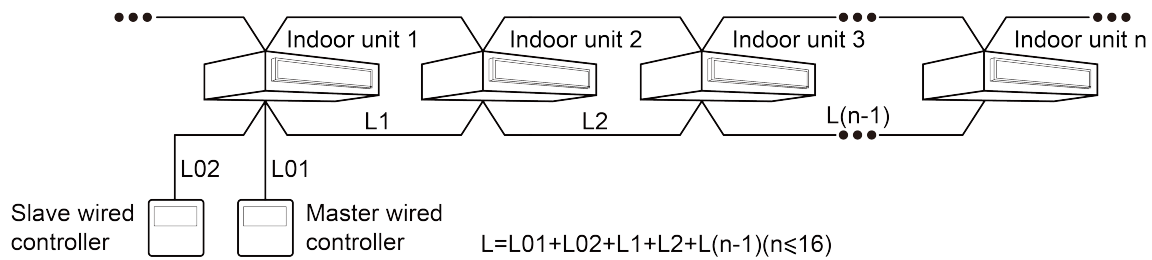

Fig.4.7.2

(2) Select communication wire between ODU and IDU

Material Type	Total Length L(m(inch)) of Communication Cable between IDU Unit and IDU (ODU) Unit	Wire size	Remarks
Light/Ordinary polyvinyl chloride sheathed cord.	$L \leq 1000(3280-7/8)$	$\geq 2 \times \text{AWG}18$	<ol style="list-style-type: none"> If the wire diameter is enlarged to 2 xAWG16, the total communication length can reach 1500m(4921-1/4inch). The cord shall be Circular cord (the cores shall be twisted together). If unit is installed in places with intense magnetic field or strong interference, it is necessary to use shielded wire.

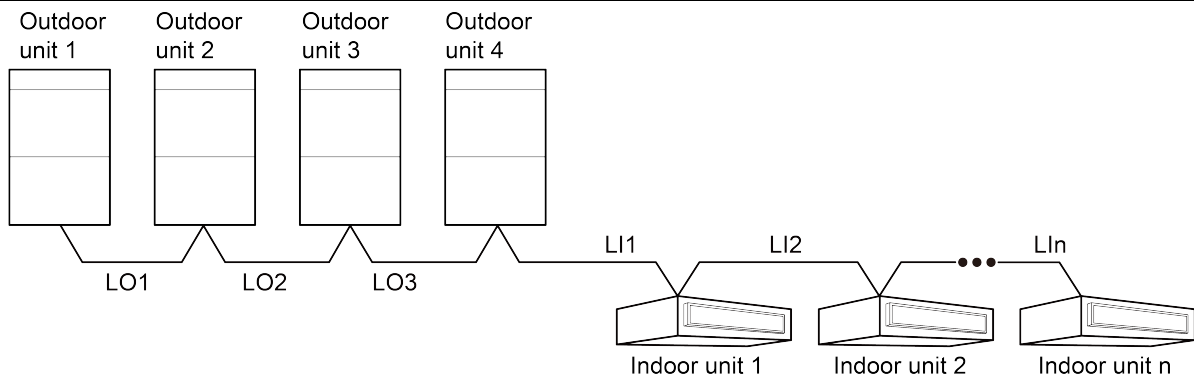

Fig.4.7.3

NOTICE All of the selected communication wire must be consistent with local laws and regulations.

4.7.3.2 Connection mode of communication

(1) All communication wires of GMV5 must be connected in series rather than in star.

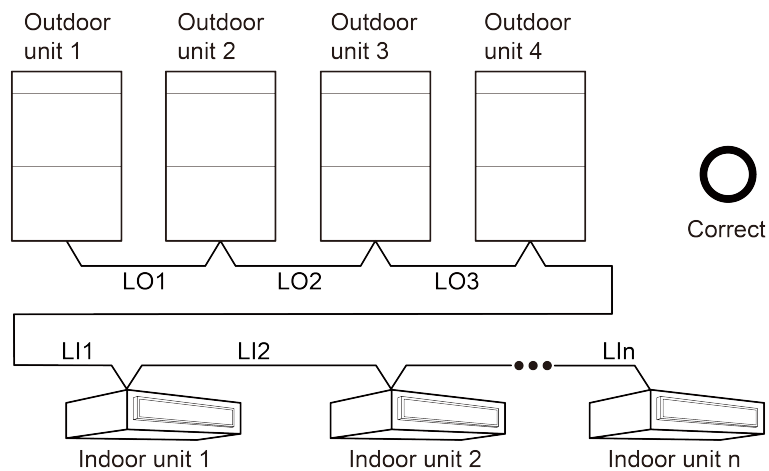

Fig.4.7.4

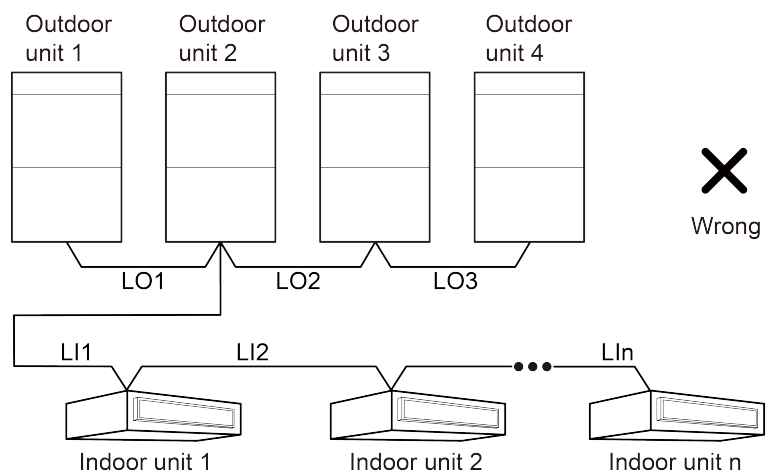

Fig.4.7.5

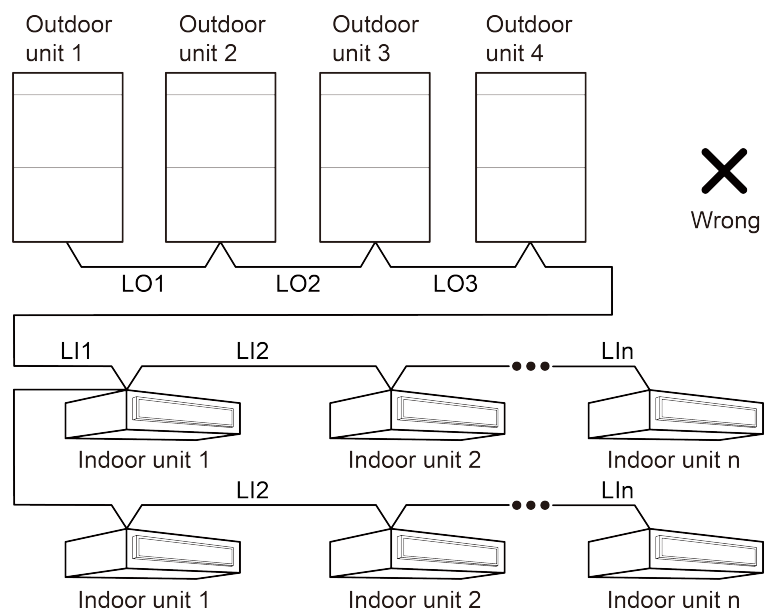

Fig.4.7.6

(2) All communication wires of GMV5 are connected by screws.

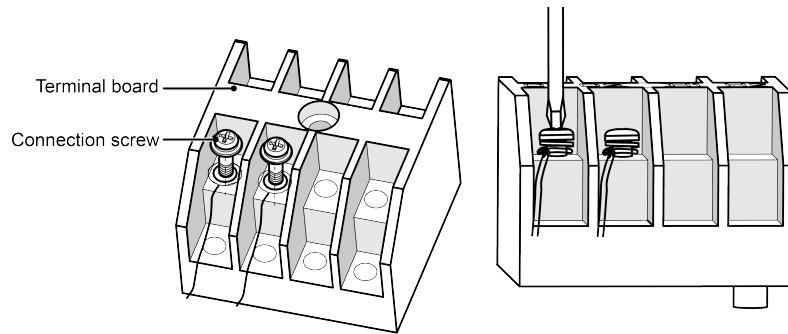

Fig.4.6.7

(3) If a single communication wire is not long enough and needs to be connected, the connected joint must be welded or pressure-welded. Do not simply twist the wires together.

4.7.4 Communication address

Auto addressing technology is adopted for GMV5 IDU and ODU. No need to set address codes manually. Only the addresses of master unit and central control are needed to be set (address of central control is only needed when there are multiple refrigeration systems).

NOTICE When installing remote monitor or central controller, displacement on indoor units' project codes must be made. Otherwise, there will be collision malfunction of the project codes. For detail operation methods, please refer to the GMV5 Installation and Maintenance Manual.

4.8 Connection Method and Steps for System Communication

4.8.1 Communication connection between IDU and ODU

NOTICE The centralized controller can be installed when it is necessary.

Connect IDU and ODU via terminal D1/D2 of communication wiring board. Below are the connection graphics of single unit and modular units:

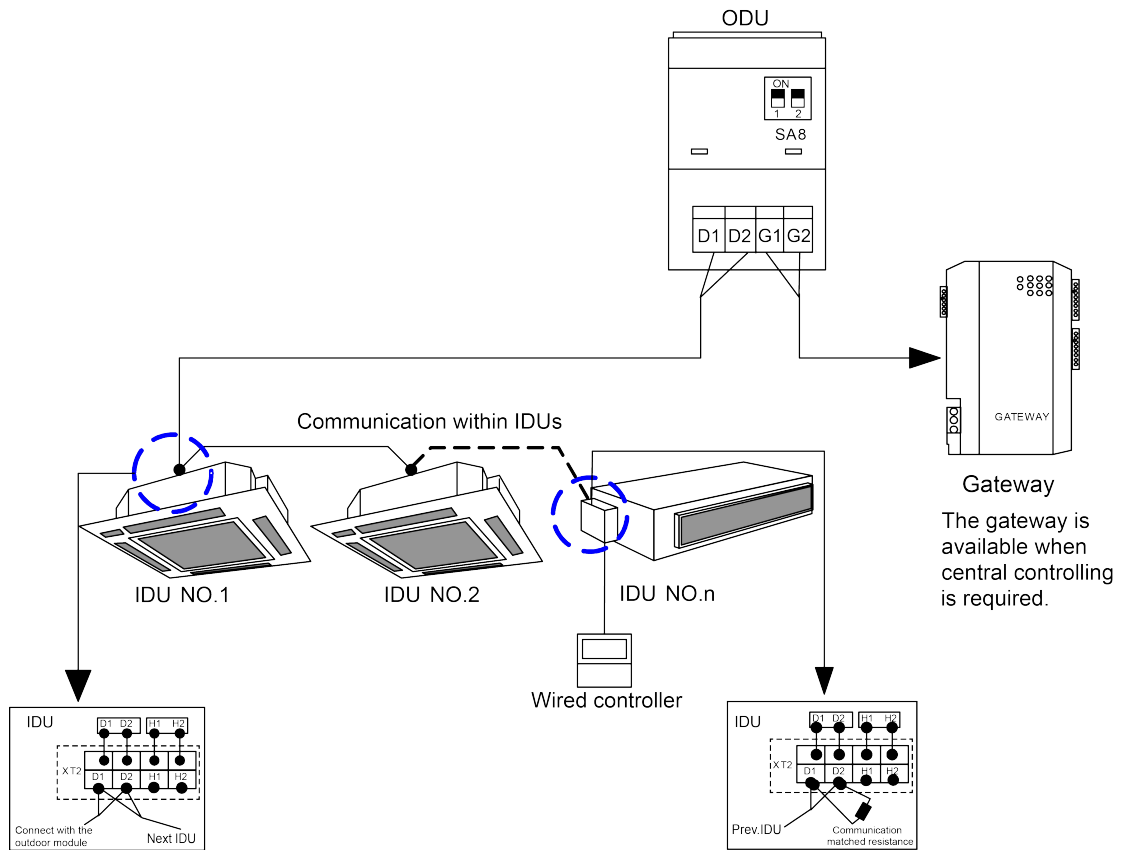

Fig.4.8.1 Connection of single unit

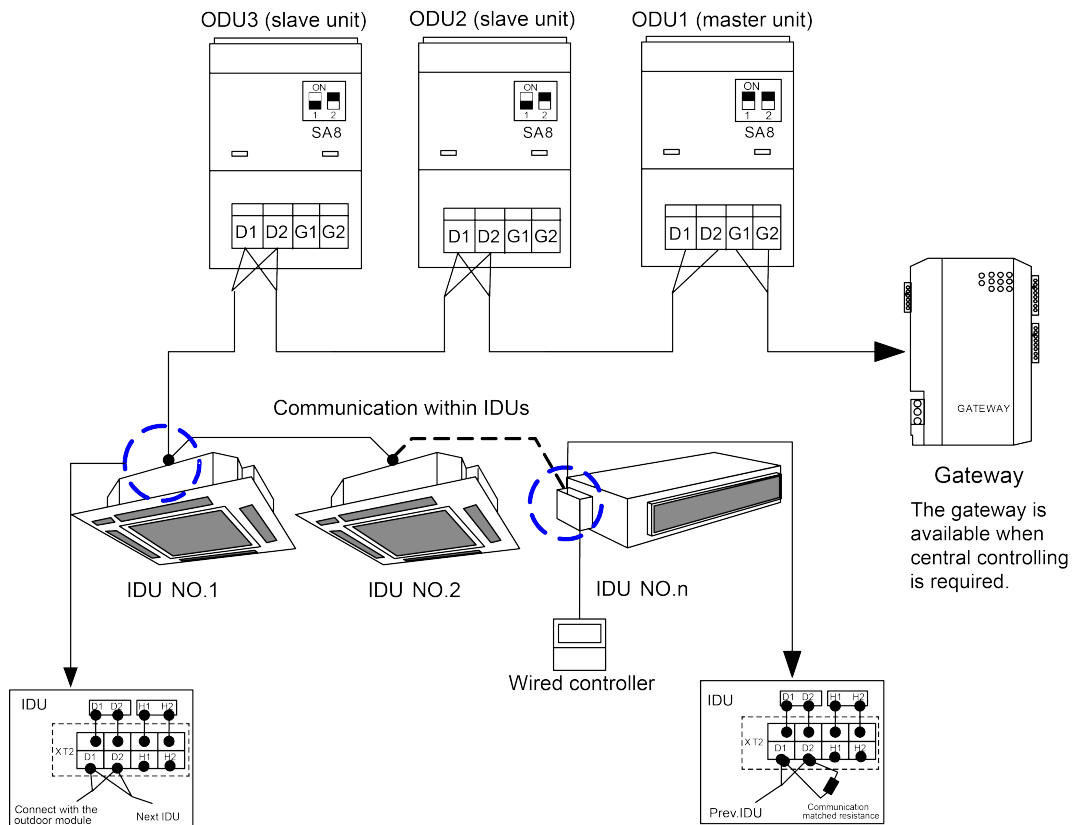

Fig.4.8.2 Connection of modular unit

NOTICE

- (1) For modular outdoor units, if there are multiple outdoor modules, then the master unit must be the first outdoor module on the communication wire and should not connect with IDU (master unit is set by SA8 of the outdoor main board).
- (2) For modular outdoor units, if there are multiple outdoor modules, then indoor units must be connected with the last slave module of ODU (slave module is set by SA8 of the outdoor main board).
- (3) Communication wire and power cord must be separated.
- (4) Communication wire must be of proper length. Extension is not allowed.
- (5) IDUs must be connected in series. The last IDU must be connected with the communication matched resistance (supplied in the list of ODU spare parts).

4.8.2 Communication connection between IDU and wired controller

There are 4 kinds of connection between IDU and wired controller, as shown below:

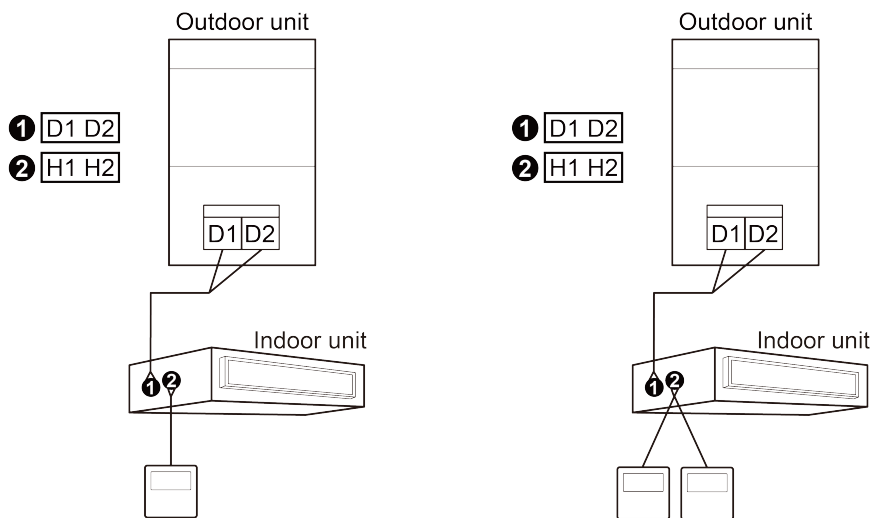

Fig.4.8.3 One wired controller controls one IDU Fig.4.8.4 Two wired controllers controls one IDU

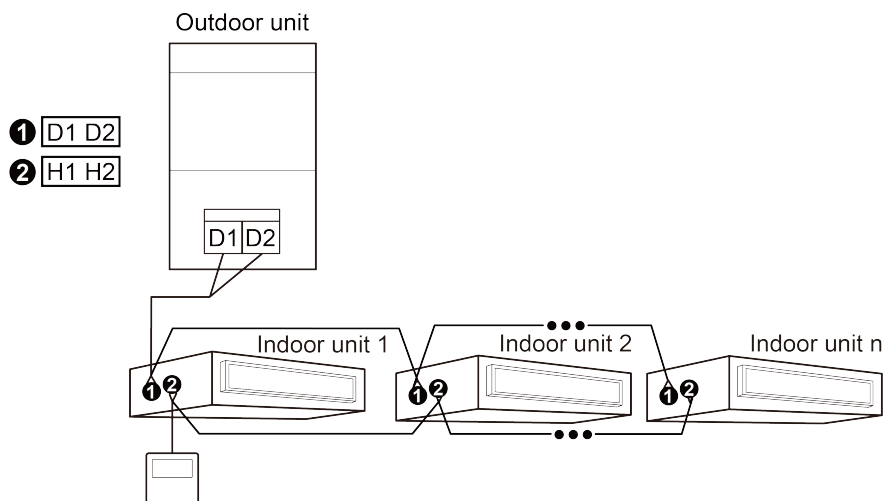

Fig.4.8.5 One wired controller controls multiple IDUs

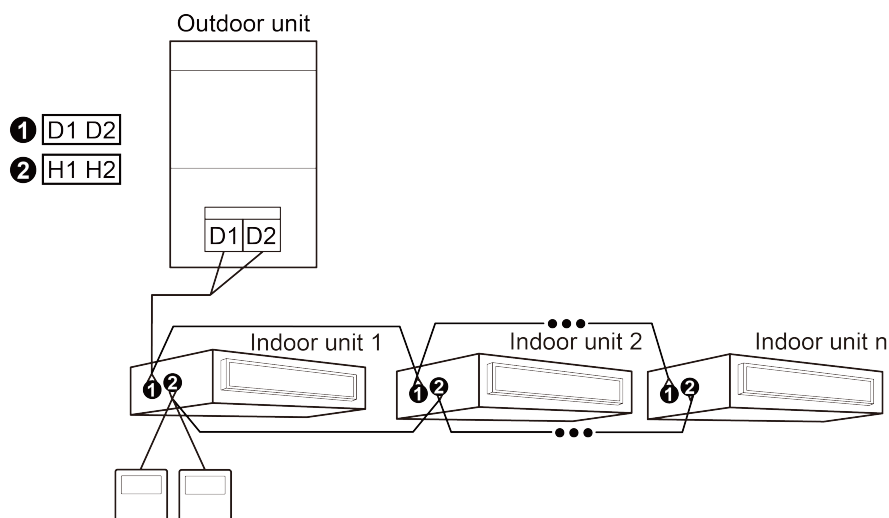

Fig.4.8.6 Two wired controllers control multiple IDUs

When two wired controllers control multiple IDUs, the wired controller can be connected to any one IDU, provided that the connected IDU is of the same series. Meanwhile, one and only one of the wired controllers must be set as a slave controller. At most 16 IDUs can be controlled by wired controllers and the connected IDUs shall be within a same IDU network.

No matter when unit is turned on or off, slave controller can be set.

How to set a slave controller: hold “function” button on the designated controller for 5s, and temperature zone displays C00. Continue holding “function” button for 5s and setting screen of controller parameter will come out. Default temperature zone displays P00.

Press ▲ button or ▼ button to select parameter code P13. Press “mode” button to switch to setup of parameter values. Then the parameter value will blink. Press ▲ button or ▼ button to select code 02. And then press “confirm/cancel” to finish setting.

Press “confirm/cancel” to return to the previous display until you exit from the setup of parameter values.

Below are user’s parameter settings:

Parameter code	Parameter name	Parameter scope	Default value	Remark
P13	Set up address for wired controller	01: master wired controller 02: slave wired controller	01	When 2 wired controllers control one or more IDUs, they shall have different addresses. Slave wired controller (02) can’t set up units’ parameters except its own address.

4.8.3 Communication connection of central controlling units

NOTICE The centralized controller can be installed when it is necessary.

Port connection G1 and G2 on the communication wiring board of master unit among each multi VRF system (see below)

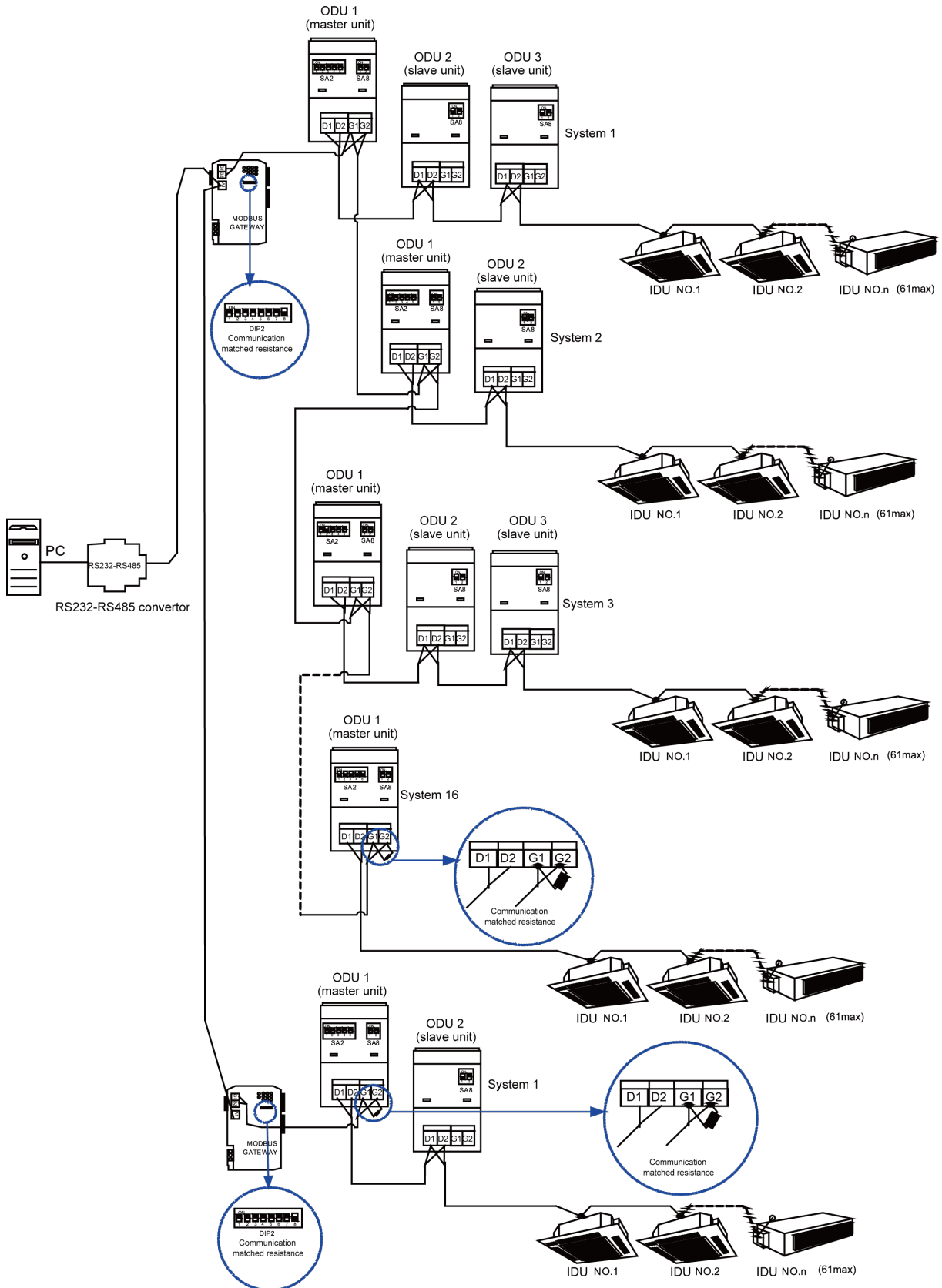
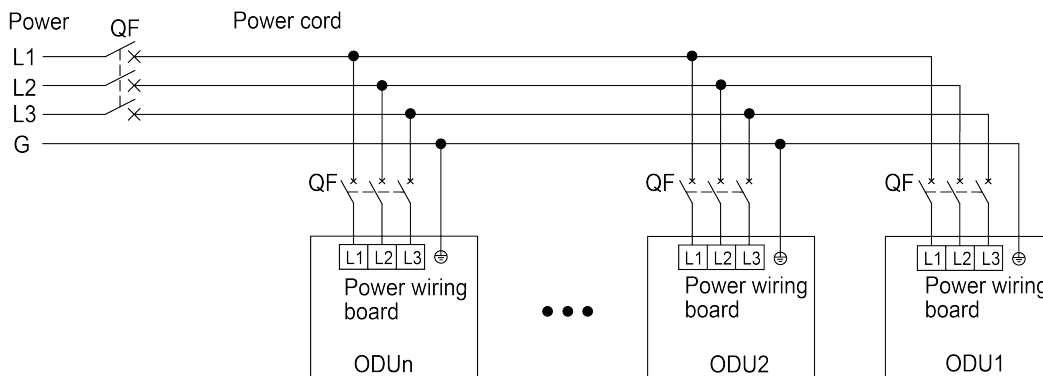

Fig.4.8.7

4.9 External Electrical Wiring Diagram

⚠WARNING
(1) Every unit should be equipped with a circuit breaker for short-circuit and overload protection. In general, circuit breaker is at OFF status.
(2) During operation, all indoor units and outdoor units belonging to the same system must be kept energized status. Otherwise, the unit can't operate normally.
(3) Power supply for the unit should comply with ratings at the nameplate.

4.9.1 External wiring diagram.



NOTICE

The maximum outdoor unit quantity "n" is decided by the combination from of outdoor unit. Please refer to the actual requirement of unit for the earthing position.

Fig.4.9.1

5 Check Items after Installation and Trial Run

5.1 Check Items after Installation

Check Items	Conditions Might Happen	Check
Has the unit been fixed firmly?	The unit may drop, shake or emit noise.	
Have you done the gas leakage test?	It may cause insufficient cooling/heating capacity.	
Is the unit get proper thermal insulation?	It may cause condensation and dripping.	
Does the unit drain well?	It may cause condensation and dripping.	
Is the voltage in accordance with the rated voltage specified on the nameplate?	It may cause malfunction or damage the part.	
Is the electric wiring and piping connection installed correctly and securely?	It may cause malfunction or damage the part.	
Has the unit been earthed securely?	It may cause electrical leakage.	
Is the power cord specified?	It may cause malfunction or damage the part.	
Has the inlet and outlet been blocked?	It may cause insufficient cooling/heating capacity.	
Has the pipe length and refrigerant charging amount been recorded?	The refrigerant charging amount is not accurate.	
Is the address code of outdoor modules correct?	The unit cannot run normally. Communication malfunction might happen.	
Is the address code of indoor units and wired controller correct?	The unit cannot run normally. Communication malfunction might happen.	
Has the communication line been connected correct?	The unit cannot run normally. Communication malfunction might happen.	
Is the piping connection and valve status right?	The unit cannot run normally.	
Whether phase sequence of external power cord is correct or not?	Operation failure occurs or unit is damaged.	
Whether the engineering piping work and wiring holes are sealed?	Maybe there are mice biting the wires, which is the cause of malfunction.	

5.2 Trial Run

NOTICE During debugging, one and only one module must be set as a master module.

During debugging, one and only one IDU must be set as a master IDU.

When no special requirement is needed, no need to set other functions. Unit can operate according to ex-factory settings. When special requirement is needed, please read the Service Manual or Debugging and Maintenance Manual.

5.2.1 Preparation before trial run

- (1) The power supply should be turned on only after finishing all the installation.
- (2) All the control wires and cables are connected correctly and safely. Completely open the gas and liquid valves.
- (3) All the objects like metal filing, thrum and clip should be cleared after installation.
- (4) Check if the unit appearance and piping system is damaged or not due to transportation.
- (5) Check if the terminals of electrical element is loose and the phase sequence is correct or not.
- (6) Check the valve: for single-module unit, fully open the gas and liquid valve and close oil balance valve; for dual/three module unit, fully open the gas, liquid valve and oil balance valve.

5.2.2 Trial run

5.2.2.1 Notices

- (1) Before test operation, make sure unit is power on and compressor has been preheated for more than 8 hours. Touch the unit to check whether it's normally preheated. Start test operation after unit is normally preheated, otherwise compressor might be damaged. Debugging must be performed by professional technicians or under the guide of professional technicians.

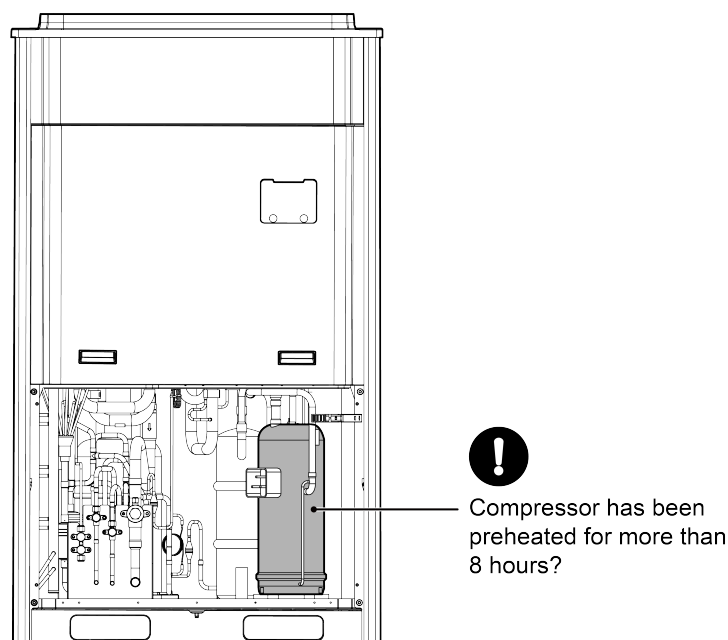

Fig.5.2.1

- (2) When debugging starts, system will operate according to the ambient temperature.
 - 1) When outdoor temperature is above 20° C(68°F), debugging shall be in cooling mode.
 - 2) When outdoor temperature is below 20° C(68°F), debugging shall be in heating mode.
- (3) Before debugging, confirm again whether the cut-off valve of each basic module is fully turned on.
- (4) During debugging, front panel of the outdoor unit must be fully closed; otherwise, debugging accuracy will be affected (see below).

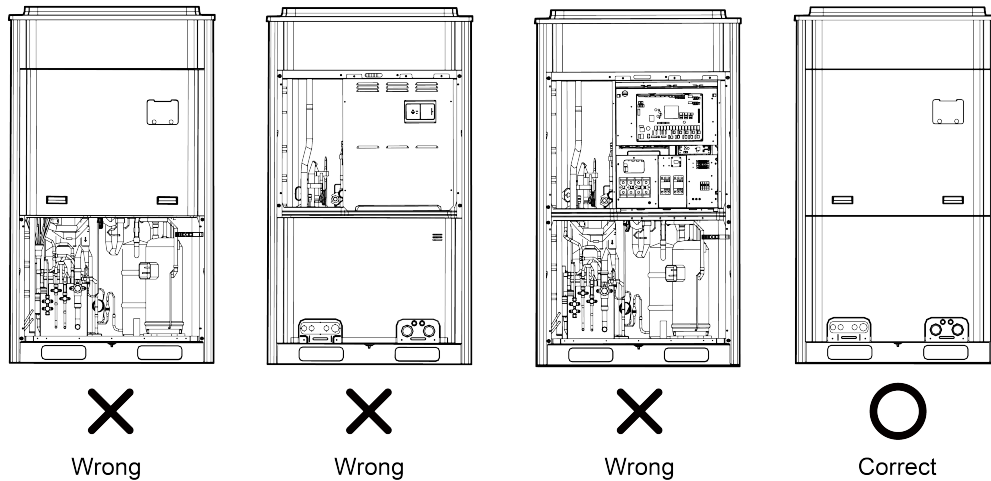

Fig.5.2.2

- (5) Before debugging, make sure the needed amount of refrigerant has been added to the pipe or at least 70% of the needed refrigerant has been added.
- (6) Description of each stage of debugging progress:

Description of each stage of debugging progress							
—	Debugging code		Progress code		Status code		Meaning
Progress	LED1		LED2		LED3		
	Code	Display status	code	Display status	Code	Display status	
01_Set up master unit	db	Light	01	Light	A0	Light	System is not debugged.
	db	Light	01	Light	CC	Light	System doesn't have master unit. Reset master unit.
	db	Light	01	Light	CF	Light	More than 2 master units are set. Reset master unit.
	db	Light	01	Light	OC	Light	Master unit is successfully set. Start next progress.
02_Allocate addresses	db	Light	02	Light	Ad	Blink	System is allocating addresses.
	db	Light	02	Light	L7	Blink	Master IDU is not set. Please set master IDU. If it's not set in 1min, system will set the master IDU randomly.
	db	Light	02	Light	OC	Light	Allocation is finished. Start next progress.
03_Confirm the quantity of modules	db	Light	03	Light	01~04	Blink	LED3 displays the quantity of modules. Confirm the number manually.
	db	Light	03	Light	OC	Light	System has confirmed the quantity of modules. Start next progress.
04_Confirm the quantity of IDUs	db	Light	04	Light	01~80	Blink	LED3 displays the quantity of IDUs. Confirm the number manually.
	db	Light	04	Light	OC	Light	System has confirmed the quantity of IDUs. Start next progress.

Description of each stage of debugging progress							
—	Debugging code		Progress code		Status code		Meaning
Progress	LED1		LED2		LED3		
	Code	Display status	code	Display status	Code	Display status	
05_Detect internal communication	db	Light	05	Light	C2	Light	System detects "driven communication error between master unit and inverter compressor".
	db	Light	05	Light	C3	Light	System detects "driven communication error between master unit and inverter fan".
	db	Light	05	Light	CH	Light	IDU/ODU "high proportion of rated capacity".
	db	Light	05	Light	CL	Light	IDU/ODU "low proportion of rated capacity".
	db	Light	05	Light	OC	Light	Detection is finished. Start next progress.
06_Detect outdoor components	db	Light	06	Light	Error code	Light	System detects error in outdoor components.
	db	Light	06	Light	OC	Light	No error in outdoor components. Start next progress.
07_Detect indoor components	db	Light	07	Light	XXXX/Error code	Light	System detects error in indoor components. XXXX is the project no. of the faulted IDU. 3s later, relevant error code is displayed. For example, IDU no. 100 has d5 error, then LED3 displays like this: 01 (2s later) 00 (2s later) d5, and repeat again.
	db	Light	07	Light	OC	Light	No error in indoor components. Start next progress.
08_Confirm preheated compressor	db	Light	08	Light	U0	Light	Preheat time for compressor is less than 8h.
	db	Light	08	Light	OC	Light	Preheat time for compressor is 8h. Start next progress.
09_Refrigerant judgments before startup	db	Light	09	Light	U4	Light	System refrigerant is not enough. System downtime equilibrium pressure is lower than 0.3MPa(4-2/5psig).
	db	Light	09	Light	OC	Light	System refrigerant is normal. Start next progress.
10_Status judgments of outdoor valves before startup	db	Light	10	Light	ON	Light	Outdoor valves are being turned on.
	db	Light	10	Light	U6	Light	Outdoor valves are not fully turned on.
	db	Light	10	Light	OC	Light	Outdoor valves are turned on normally.
11_Calculate refrigerant quantity manually	db	Light	11	Light	AE	Light	Calculate the refrigerant quantity manually and confirm the perfusion status of refrigerant (the quantity of refrigerant added into the system must be recorded accurately).
12_Confirm debugging startup	db	Light	12	Light	AP	Blink	Ready for units to start debugging.
	db	Light	12	Light	AE	Light	Manual calculation of refrigerant quantity is set up.
13_	—	—	—	—	—	—	No meaning.
14_	—	—	—	—	—	—	No meaning.
15_Cooling debugging	db	Light	15	Light	AC	Light	Debugging is enabled in cooling mode (debugging mode, auto-selected by system).
	db	Light	15	Light	Error code	Light	Error occurs during debugging in cooling mode.
	db	Light	15	Light	J0	Light	Error of other modules occurs during debugging in cooling mode.

Description of each stage of debugging progress							
—	Debugging code		Progress code		Status code		Meaning
Progress	LED1		LED2		LED3		
	Code	Display status	code	Display status	Code	Display status	
15_Cooling debugging	db	Light	15	Light	U9	Light	Outdoor pipeline and valves are not normal.
	db	Light	15	Light	XXXX/U8	Light	System detects error in indoor pipeline. XXXX is the project no. of the faulted IDU. 3s later, error code U8 is displayed. For example, IDU no. 100 has U8 error, then LED3 displays like this: 01 (2s later) 00 (2s later) U8, and repeat again.
16_Heating debugging	db	Light	16	Light	AH	Light	Debugging is enabled in heating mode (debugging mode, auto-selected by system).
	db	Light	16	Light	Error code	Light	Error occurs during debugging in heating mode.
	db	Light	16	Light	J0	Light	Error of other modules occurs during debugging in heating mode.
	db	Light	16	Light	U9	Light	Outdoor pipeline and valves are not normal.
	db	Light	16	Light	XXXX/U8	Light	System detects error in indoor pipeline. XXXX is the project no. of the faulted IDU. 3s later, error code U8 is displayed. For example, IDU no. 100 has U8 error, then LED3 displays like this: 01 (2s later) 00 (2s later) U8, and repeat again.
17_Debugging finished	01~04	Light	OF	Light	OF	Light	Debugging is finished. System is on standby condition. LED1 displays module address. LED2 and LED3 display "OF".

5.2.2.2 Debugging operation mode

GMV5 multi VRF system has two debugging modes: one is direct operation on main board of outdoor units while the other is PC operation via special software. In PC software debugging, indoor/outdoor parameters can be displayed and historical data can be recorded and inquired. (Operation details can be found in relevant instruction manuals)

(1) Debugging through operation on main board of outdoor units

In this debugging mode, following debugging functions are included on the main board:

Step 1: front panel of the outdoor units must be fully closed. Open the debugging window of each basic module;

Step 2: disconnect power for outdoor units. According to design requirements of external static pressure, set up corresponding static pressure mode for the units. Setting methods can be seen in Outdoor Fan Static Pressure Setup SA6_ESP_S;

Step 3: disconnect power for outdoor units and set one module as a master unit. Setting methods can be seen in Master Unit Setup SA8_MASTER_S;

Step 4: Connect power for all indoor units. Make sure all IDUs are power on. Then all outdoor modules will display "Debugging not enabled";

Step 5: Find the module with "01" module address to be the master module. Hold SW7 button on the master module for at least 5s to enable debugging;

Step 6: Wait. Unit will then start progress 01 and 02; in progress 01, if master unit is not correctly set, progress 01 will show the following errors:

Progress	Debugging Code		Progress Code		Status Code		Meaning
	LED1		LED2		LED3		
	Code	Display status	Code	Display status	Code	Display status	
01_01 Set up master unit:	db	Light	01	Light	CC	Light	System doesn't have master unit. Reset master unit.
	db	Light	01	Light	CF	Light	More than 2 master units are set. Reset master unit.
	db	Light	01	Light	OC	Light	Master unit is successfully set. Start next progress.

According to the above errors, reset the master unit as instructed in Master Unit Setup SA8_MASTER_S. After reset is finished, start debugging again.

In progress 02, if master IDU is not detected, then progress 02 will show the following errors:

LED1		LED2		LED3	
Function code	Display mode	Current progress	Display mode	Current status	Display mode
db	Light	02	Light	L7	Blink

At this time, all buttons are ineffective. Set master IDU in 1min via debugging software. If master IDU is not set in 1min, system will set up a master IDU randomly. After that, system will start next progress.

Step 7: in progress 03, the quantity of modules needs to be confirmed manually. Main board of each module will display:

Progress	Debugging code		Progress code		Status code	
	LED1		LED2		LED3	
	Code	Display status	Code	Display status	Code	Display status
03_Quantity of modules	db	Light	03	Light	Quantity of modules	Blink

If the quantity displayed is the same with actual quantity, then press SW7 confirmation button on the master unit to confirm it. Unit will start next progress:

Progress	Debugging code		Progress code		Status code	
	LED1		LED2		LED3	
	Code	Display status	Code	Display status	Code	Display status
03_Confirm the quantity of modules	db	Light	03	Light	OC	Light

If the quantity displayed is different from actual quantity, then disconnect power and check whether communication wire among each module is correctly connected. After the check, start debugging again.

Step 8: in progress 04, the quantity of IDUs needs to be confirmed manually. Main board of each module will display:

Progress	Debugging code		Progress code		Status code	
	LED1		LED2		LED3	
	Code	Display status	Code	Display status	Code	Display status
04_Confirm the quantity of IDUs	db	Light	04	Light	Quantity of connected IDUs	Blink

If the quantity displayed is the same with actual quantity, then press SW7 confirmation button on the master unit to confirm it. Unit will start next progress:

—	Debugging code		Progress code		Status code	
Progress	LED1		LED2		LED3	
	Code	Display status	Code	Display status	Code	Display status
04_Confirm the quantity of IDUs	db	Light	04	Light	OC	Light

Step 9: progress 05 is “Detect internal communication”

If no error is detected, system will display as below and then start next progress.

—	Debugging code		Progress code		Status code		Meaning
Progress	LED1		LED2		LED3		
	Code	Display status	code	Display status	Code	Display status	
05_Detect internal communication	db	Light	05	Light	OC	Light	Detection is finished. Start next progress.

If error is detected, system will stay at current progress. Error has to be solved manually. Below are relevant errors:

—	Debugging code		Progress code		Status code		Meaning
Progress	LED1		LED2		LED3		
	Code	Display status	code	Display status	Code	Display status	
05_Detect internal communication	db	Light	05	Light	C2	Light	System detects “driven communication error between master unit and inverter compressor”.
	db	Light	05	Light	C3	Light	System detects “driven communication error between master unit and inverter fan”.
	db	Light	05	Light	CH	Light	IDU/ODU “high proportion of rated capacity”.
	db	Light	05	Light	CL	Light	IDU/ODU “low proportion of rated capacity”.

Elimination methods of above errors can be found in Troubleshooting.

Step 10: progress 06 is “Detect outdoor components”

If no error is detected, system will display as below and then start next progress.

—	Debugging code		Progress code		Status code		Meaning
Progress	LED1		LED2		LED3		
	Code	Display status	code	Display status	Code	Display status	
06_Detect outdoor components	db	Light	06	Light	OC	Light	No error is detected in outdoor components. Start next progress.

If error is detected, system will stay at current progress. Error has to be solved manually. Below is relevant error:

—	Debugging code		Progress code		Status code		Meaning
Progress	LED1		LED2		LED3		
	Code	Display status	code	Display status	Code	Display status	
06_Detect outdoor components	db	Light	06	Light	Error code	Light	System detects error in outdoor components.

Elimination methods of above error can be found in Troubleshooting.

Step11: progress 07 is “Detect indoor components”

If no error is detected, system will display as below and then start next progress.

—	Debugging code		Progress code		Status code		Meaning
Progress	LED1		LED2		LED3		
	Code	Display status	code	Display status	Code	Display status	
07_Detect indoor components	db	Light	07	Light	OC	Light	No error is detected in indoor components. Start next progress.

If error is detected, system will stay at current progress. Error has to be solved manually. Below is relevant error:

—	Debugging code		Progress code		Status code		Meaning
Progress	LED1		LED2		LED3		
	Code	Display status	code	Display status	Code	Display status	
07_Detect indoor components	db	Light	07	Light	XXXXor Error code	Light	System detects error in indoor components.

XXXX is the project no. of the faulted IDU. 3s later, relevant error code is displayed. For example, IDU no. 100 has d5 error, then LED3 displays like this: 01 (2s later) 00 (2s later) d5, and repeat again.

Elimination methods of above error can be found in Troubleshooting.

Step 12: progress 08 is “Confirm preheated compressor”

If more than 8h of preheat time is detected, system will display as below and start next progress.

—	Debugging code		Progress code		Status code		Meaning
Progress	LED1		LED2		LED3		
	Code	Display status	code	Display status	Code	Display status	
08_Confirm preheated compressor	db	Light	08	Light	OC	Light	Preheat time for compressor is 8h. Start next progress.

If less than 8h of preheat time is detected, system will give error alarm and display as below. Then press SW7 confirmation button to skip the wait time and start next progress. But this will cause force start of the compressor, which may damage the compressor.

—	Debugging code		Progress code		Status code		Meaning
Progress	LED1		LED2		LED3		
	Code	Display status	code	Display status	Code	Display status	
08_Confirm preheated compressor	db	Light	08	Light	UO	Light	Preheat time for compressor is less than 8h.

Step 13: progress 09 is “Refrigerant judgments before startup”

If the refrigerant quantity inside the system meets the requirement of operation startup, system will display as below and start next progress.

—	Debugging code		Progress code		Status code		Meaning
Progress	LED1		LED2		LED3		
	Code	Display status	code	Display status	Code	Display status	
09_Refrigerant judgments before startup	db	Light	09	Light	OC	Light	System refrigerant is normal. Start next progress.

If there’s no or not enough refrigerant in the system to meet the requirement of operation startup, system will display U4 “refrigerant shortage protection” and fails to start next progress. Then check if there’s any leakage or add refrigerant inside until error eliminated.

—	Debugging code		Progress code		Status code		Meaning
Progress	LED1		LED2		LED3		
	Code	Display status	code	Display status	Code	Display status	
09_Refrigerant judgments before startup	db	Light	09	Light	O4	Light	System refrigerant is not enough. System downtime equilibrium pressure is lower than 0.3MPa(4-2/5psig).

Step 14: progress 10 is “Status judgments of outdoor valves before startup”

If master unit displays below, status judgments are enabled.

—	Debugging code		Progress code		Status code		Meaning
Progress	LED1		LED2		LED3		
	Code	Display status	code	Display status	Code	Display status	
10_Status judgments of outdoor valves before startup	db	Light	10	Light	ON	Light	Outdoor valves are being turned on.

If unit detects that valve status is not normal, it will display as below:

—	Debugging code		Progress code		Status code		Meaning
Progress	LED1		LED2		LED3		
	Code	Display status	code	Display status	Code	Display status	
10_Status judgments of outdoor valves before startup	db	Light	10	Light	U6	Light	Outdoor valves are not fully turned on.

Then check the big and small valves whether they are fully turned on. After the check, press SW6 return button to restart the judgments.

If unit detects that valve status is normal, it will display as below and start next progress.

—	Debugging code		Progress code		Status code		Meaning
Progress	LED1		LED2		LED3		
	Code	Display status	code	Display status	Code	Display status	
10_Status judgments of outdoor valves before startup	db	Light	10	Light	OC	Light	Outdoor valves are turned on normally.

Step 15: progress 11 is “Calculate refrigerant quantity manually”

No need to operate. System will start next progress.

Step 16: progress 12 is “Confirm debugging startup”

In order to make sure all preparation work is done before startup, this step is designed for user to confirm the startup again. Operate as below:

If master unit displays as below, system is waiting for confirmation signal.

—	Debugging code		Progress code		Status code		Meaning
Progress	LED1		LED2		LED3		
	Code	Display status	code	Display status	Code	Display status	
12_Status judgments of outdoor valves before startup	db	Light	12	Light	AP	Blink	Ready for units to start debugging.

If it's confirmed, press SW7 confirmation button. Unit will display as below and start next progress.

—	Debugging code		Progress code		Status code		Meaning
Progress	LED1		LED2		LED3		
	Code	Display status	code	Display status	Code	Display status	
12_Status judgments of outdoor valves before startup	db	Light	12	Light	AE	Light	Manual calculation of refrigerant quantity is set up.

Step 17: after unit is confirmed to start debugging, system select cooling/heating mode according to ambient temperature.

A If cooling mode is selected, relevant display is as below:

GMV DC Inverter VRF

—	Debugging code		Progress code		Status code		Meaning
Progress	LED1		LED2		LED3		
	Code	Display status	code	Display status	Code	Display status	
15_Cooling debugging	db	Light	15	Light	AC	Light	Debugging is enabled in cooling mode (debugging mode, auto-selected by system).
	db	Light	15	Light	Error code	Light	Error occurs during debugging in cooling mode.
	db	Light	15	Light	J0	Light	Error of other modules occurs during debugging in cooling mode.
	db	Light	15	Light	U9	Light	Outdoor pipeline and valves are not normal.
	db	Light	15	Light	XXXX/U8	Light	System detects error in indoor pipeline. XXXX is the project no. of the faulted IDU. 3s later, error code U8 is displayed. For example, IDU no. 100 has U8 error, then LED3 displays like this: 01 (2s later) 00 (2s later) U8, and repeat again.

B If heating mode is selected, relevant display is as below:

—	Debugging code		Progress code		Status code		Meaning
Progress	LED1		LED2		LED3		
	Code	Display status	code	Display status	Code	Display status	
16_Heating debugging	db	Light	16	Light	AE	Light	Debugging is enabled in heating mode (debugging mode, auto-selected by system).
	db	Light	16	Light	Error code	Light	Error occurs during debugging in heating mode.
	db	Light	16	Light	J0	Light	Error of other modules occurs during debugging in heating mode.
	db	Light	16	Light	U9	Light	Outdoor pipeline and valves are not normal.
	db	Light	16	Light	XXXX/U8	Light	System detects error in indoor pipeline. XXXX is the project no. of the faulted IDU. 3s later, error code U8 is displayed. For example, IDU no. 100 has U8 error, then LED3 displays like this: 01 (2s later) 00 (2s later) U8, and repeat again.

Step 18: if there's no error during operation for about 40min, system will automatically confirm that debugging is finished and then stop. System resumes standby condition and displays as below:

—	Debugging code		Progress code		Status code		Meaning
Progress	LED1		LED2		LED3		
	Code	Display status	code	Display status	Code	Display status	
17_Debugging finished	01-04	Light	OF	Light	OF	Light	Debugging is finished. System is on standby condition. LED1 displays module address. LED2 and LED3 display "OF".

Step 19: after debugging is finished, some functions can be set up according to project's actual needs. For specific details, please refer to System Functions Setup. If no special requirements, skip this step.

Step 20: deliver the product to user and inform user about usage precautions.

5.2.3 Appendix: judgment reference of normal operational parameters

Reference of Debug Parameters of GMV5 DC Inverter Multi VRF System					
No.	Debug item	Parameter name	Unit	Reference	
1	System parameters	ODU	Outdoor ambient temp	°C(°F)	—
2			Discharge tube temp of inverter compressor 1	°C(°F)	<ul style="list-style-type: none"> When system compressor starts up, temp of discharge tube or casing top in cooling mode is within 70~95°C (158~203°F), and at least 10°C(50°F) higher than system high pressure saturation temp; temp in heating mode is within 65~80°C(149~176°F), and at least 10°C(50°F) higher than system high pressure saturation temp. When inverter compressor starts but inverter compressor 2 stops, the discharge tube temperature of inverter compressor 2 is almost the same with ambient temp.
3			Casing top temp. of inverter compressor 1	°C(°F)	
4			Discharge tube temp of inverter compressor 2	°C(°F)	
5			Casing top temp of inverter compressor 2	°C(°F)	
6			Defrost temp 1	°C(°F)	
7			System high pressure	°C(°F)	<ul style="list-style-type: none"> System's normal high pressure value is within 20~55°C(68~131°F) According to the change in ambient temp. and system operational capacity, system's high pressure value is 10~40°C(50~104°F) higher than ambient temp. The higher ambient temp is, the smaller temp. difference is. When ambient temp. is 25~35°C(77~95°F), system's high pressure value in cooling mode is 44~53°C (111.2~127.4°F). When ambient temp. is -5~10°C(23~50°F), system's high pressure value in heating mode is 40~52°C(104~125.6°F).
8			System low pressure	°C(°F)	<ul style="list-style-type: none"> When ambient temp. is 25~35°C(77~95°F), system's low pressure value in cooling mode is 0~8°C(32~46.4°F). When ambient temp. is -5~10°C(23~50°F), system's low pressure value in heating mode is -15~5°C(5~41°F).
9			Opening angle of heating EXV	PLS	<ul style="list-style-type: none"> In cooling mode, heating electronic expansion valve remains 480PLS. In heating mode, the opening angle of adjustable electronic expansion valve varies within 120~480PLS.
10			Operating freq. of inverter compressor*	Hz	Varies from 20Hz to 100Hz
11			IPM temp of inverter compressor	°C(°F)	When ambient temp. is lower than 35°C(95°F), IPM temp. is below 85°C(185°F). Highest temp. won't be above 95°C(203°F).
12			Inverter compressor driven bus voltage	V	Normal bus voltage is 1.414 times of power voltage. For example, if 3-phase power voltage is 460V, then the bus voltage after rectification is: 460V×1.414=650V. It's normal if actual voltage varies 15V from the calculated voltage.
13			Operating freq of fan motor	Hz	Adjusts in 0~65Hz according to system pressure.

Reference of Debug Parameters of GMV5 DC Inverter Multi VRF System					
No.	Debug item	Parameter name	Unit	Reference	
14	System parameters	IDU	Ambient temp of IDU	°C(°F)	—
15			Inlet tube temp of indoor heat exchanger	°C(°F)	<ul style="list-style-type: none"> • According to different ambient temp, for a same IDU under cooling mode, inlet tube temp will be 1~7°C(33.8~44.6°F) lower than outlet tube temp. • For a same IDU under heating mode, inlet tube temp will be 10~20°C(50~68°F) lower than outlet tube temp.
16			Outlet tube temp of indoor heat exchanger	°C(°F)	
17			Opening angle of indoor EXV	PLS	Adjusts opening angle automatically in 200~2000PLS or 70~480PLS.
18	Communication parameter	Communication data	—	Quantity of IDU and ODU detected by software is the same with actual quantity. No communication error.	
19	Drainage system	—	—	IDU can drain water out completely and smoothly. Condensate pipe has no backward slope of water. Water of ODU can be drained completely through drainage pipe. No water drop from unit base.	
20	Others	—	°C(°F)	Compressor and indoor/outdoor fan motor has no strange noise. Unit operates normally.	

*Different compressor operating frequency ranges are different.

6 Common Malfunction and Troubleshooting

Check the following items before contacting for repair.

Phenomenon	Reason	Measure
The unit doesn't run.	Without power supply	Connect to power supply
	Voltage is too low	Check if the voltage is within rating range
	Broken fuse or breaker trips off	Replace fuse or connect breaker
	Insufficient energy of remote controller	Replace new battery
	Remote controller is out of control scope	Control scope is within 8m
Unit runs but stop immediately	Air intake or outlet of indoor or outdoor unit is blocked	Remove obstruction
Abnormal cooling or heating	Air intake or outlet of indoor or outdoor unit is blocked	Remove obstruction
	Improper temperature setting	Adjust setting at wireless remote controller or wired controller
	Fan speed is set too low	Adjust setting at wireless remote controller or wired controller
	Wind direction is not correct	Adjust setting at wireless remote controller or wired controller
	Door or windows are opened	Close the door or windows
	Direct sunshine	Draw curtain or louver
	Too many people in the room	—
	Too many heat resources in the room	Reduce heat resources
Filter is blocked for dirt	Clean the filter	

NOTICE

- (1) When installing remote monitor or central controller, displacement on indoor units' project codes must be made. Otherwise, there will be collision malfunction of the project codes. For detail operation methods, please refer to the GMV5 Installation and Maintenance Manual.
- (2) If problem cannot be solved after checking the above items, please contact Gree service center and show phenomena and models.

Following circumstance are not malfunction.

"Malfunction"		Reason
Unit doesn't run	When unit is started immediately after it is just turned off	Overload protection switch makes it run after 3 minutes delay
	When power is turned on	Standby operating for about 1 minute
Mist comes from the unit	Under cooling	Indoor high humidity air is cooled rapidly
Noise is emitted	Slight cracking sound is heard when just turned on	It is noise when electronic expansion valve initialization
	There is consecutive sound when cooling	That's sound for gas refrigerant flowing in unit
	There is sound when unit starts or stops	That's sound for gas refrigerant stops to flow
	There is slight and consecutive sound when unit is running or after running	That's sound for operation of drainage system
The unit blows out duct	Cracking sound is heard when unit is operating and after operating	That's sound caused by expansion of panel and other parts due to temperature change
	When unit runs after no operation for a long period	Dust in indoor unit is blew out
The unit emits odor	Operating	The room odor absorbed by the unit is blew out again
Indoor unit still runs after switch off	After every indoor unit receive "stop" signal, fan will keep running	Indoor fan motor will keep running 20-70s so as to take good use of excess cooling and heating and prepare for next operation
Mode conflict	COOL or HEAT mode cannot be operated	When the indoor operating mode conflicts with that of outdoor unit, indoor fault indicator will flash and conflict will be shown on the wired controller after 5 minutes. Indoor unit stops to run and meanwhile change outdoor operating mode as the same as that of indoor unit, then the unit will go back to normal. COOL mode doesn't conflict with DRY mode. FAN mode doesn't conflict with any mode.

7 Error Indication

Inquiry method of malfunction display: combine division number and content number to check the corresponding malfunction.

Indoor:

Error Code	Content	Error Code	Content
L0	Malfunction of IDU	d2	Malfunction of lower water temperature sensor of water tank
L1	Protection of indoor fan	d3	Malfunction of ambient temperature sensor
L2	Auxiliary heating protection	d4	Malfunction of entry-tube temperature sensor
L3	Water-full protection	d6	Malfunction of exit-tube temperature sensor
L4	Abnormal power supply for wired controller	d7	Malfunction of humidity sensor
L5	Freeze prevention protection	d8	Malfunction of water temperature sensor
L7	No main IDU	d9	Malfunction of jumper cap
L8	Power supply is insufficient	dA	Web address of IDU is abnormal
L9	For single control over multiple units, number of IDU is inconsistent	dH	PCB of wired controller is abnormal
LA	For single control over multiple units, IDU series is inconsistent	dC	Setting capacity of DIP switch code is abnormal
LH	Alarm due to bad air quality	dL	Malfunction of air outlet temperature sensor
LC	IDU is not matching with outdoor unit	dE	Malfunction of indoor CO ₂ sensor
LL	Malfunction of water flow switch	dF	Malfunction of upper water temperature sensor of water tank
LE	Rotation speed of EC DC water pump is abnormal	dJ	Malfunction of backwater temperature sensor
LF	Malfunction of shunt valve setting	dP	Malfunction of inlet tube temperature sensor of generator
LJ	Setting of functional DIP switch code is wrong	dU	Malfunction of drainage pipe temperature sensor of generator
LP	Zero-crossing malfunction of PG motor	db	Debugging status
LU	Indoor unit's branch is not inconsistent for one-to-more unit of heat recovery system	dd	Malfunction of solar power temperature sensor
d1	Indoor PCB is poor	dn	Malfunction of swing parts

Outdoor:

Error Code	Content	Error Code	Content
E0	Malfunction of ODU	FH	Current sensor of compressor 1 is abnormal
E1	High-pressure protection	FC	Current sensor of compressor 2 is abnormal
E2	Discharge low-temperature protection	FL	Current sensor of compressor 3 is abnormal
E3	Low-pressure protection	FE	Current sensor of compressor 4 is abnormal
E4	High discharge temperature protection of compressor	FF	Current sensor of compressor 5 is abnormal
J0	Protection for other modules	FJ	Current sensor of compressor 6 is abnormal
J1	Over-current protection of compressor 1	FP	Malfunction of DC motor
J2	Over-current protection of compressor 2	FU	Malfunction of casing top temperature sensor of compressor 1
J3	Over-current protection of compressor 3	Fb	Malfunction of casing top temperature sensor of compressor 2
J4	Over-current protection of compressor 4	Fd	Malfunction of exit tube temperature sensor of mode exchanger
J5	Over-current protection of compressor 5	Fn	Malfunction of inlet tube temperature sensor of mode exchanger
J6	Over-current protection for compressor 6	b1	Malfunction of outdoor ambient temperature sensor
J7	Gas-mixing protection of 4-way valve	b2	Malfunction of defrosting temperature sensor 1
J8	High pressure ratio protection of system	b3	Malfunction of defrosting temperature sensor 2
J9	Low pressure ratio protection of system	b4	Malfunction of liquid temperature sensor of sub-cooler
JA	Protection because of abnormal pressure	b5	Malfunction of gas temperature sensor of sub-cooler
JC	Water flow switch protection	b6	Malfunction of inlet tube temperature sensor of vapor liquid separator
JL	Protection because high pressure is too low	b7	Malfunction of exit tube temperature sensor of vapor liquid separator
JE	Oil-return pipe is blocked	b8	Malfunction of outdoor humidity sensor
JF	Oil-return pipe is leaking	b9	Malfunction of gas temperature sensor of heat exchanger
P0	malfunction of driving board of compressor	bA	Malfunction of oil-return temperature sensor 1
P1	Driving board of compressor operates abnormally	bH	Clock of system is abnormal
P2	Voltage protection of driving board power of compressor	bE	Malfunction of inlet tube temperature sensor of condenser
P3	Reset protection of driving module of compressor	bF	Malfunction of outlet tube temperature sensor of condenser
P4	Drive PFC protection of compressor	bJ	High-pressure sensor and low-pressure sensor are connected reversely
P5	Over-current protection of inverter compressor	bP	Malfunction of temperature sensor of oil-return 2
P6	Drive IPM module protection of compressor	bU	Malfunction of temperature sensor of oil return 3
P7	Malfunction of drive temperature sensor of compressor	bb	Malfunction of temperature sensor of oil return 4

GMV DC Inverter VRF

Error Code	Content	Error Code	Content
P8	Drive IPM high temperature protection of compressor	H0	Malfunction of driving board of fan
P9	Desynchronizing protection of inverter compressor	H1	Driving board of fan operates abnormally
PA	Malfunction of drive storage chip of compressor	H2	Voltage protection of driving board power of fan
PH	High-voltage protection of compressor's drive DC bus bar	H3	Reset protection of driving module of fan
PC	Malfunction of current detection circuit drive of compressor	H4	Drive PFC protection of fan
PL	Low voltage protection for DC bus bar of drive of compressor	H5	Over-current protection of inverter fan
PE	Phase-lacking of inverter compressor	H6	Drive IPM module protection of fan
PF	Malfunction of charging loop of driven of compressor	H7	Malfunction of drive temperature sensor of fan
PJ	Failure startup of inverter compressor	H8	Drive IPM high temperature protection of fan
PP	AC current protection of inverter compressor	H9	Desynchronizing protection of inverter fan
PU	AC input voltage of drive of inverter compressor	HA	Malfunction of drive storage chip of inverter outdoor fan
F0	Main board of ODU is poor	HH	High-voltage protection of fan's drive DC bus bar
F1	Malfunction of high-pressure sensor	HC	Malfunction of current detection circuit of fan drive
F3	Malfunction of low-pressure sensor	HL	Low voltage protection of bus bar of fan drive
F5	Malfunction of discharge temperature sensor of compressor 1	HE	Phase-lacking of inverter fan
F6	Malfunction of exit-tube temperature sensor	HF	Malfunction of charging loop of fan drive
F7	Malfunction of humidity sensor	HJ	Failure startup of inverter fan
F8	Malfunction of water temperature sensor	HP	AC current protection of inverter fan
F9	Malfunction of jumper cap	HU	AC input voltage of drive of inverter fan
FA	Web address of IDU is abnormal	—	—

Debugging:

Error Code	Content	Error Code	Content
U0	Preheat time of compressor is insufficient	C6	Alarm because ODU quantity is inconsistent
U2	Wrong setting of ODU's capacity code/jumper cap	C7	Abnormal communication of converter
U3	Power supply phase sequence protection	C8	Emergency status of compressor
U4	Refrigerant-lacking protection	C9	Emergency status of fan
U5	Wrong address for driving board of compressor	CA	Emergency status of module
U6	Alarm because valve is abnormal	CH	Rated capacity is too high
U8	Malfunction of pipeline for IDU	CC	No main unit
U9	Malfunction of pipeline for ODU	CL	The matching ratio of rated capacity for IDU and ODU is too low
UC	Setting of main IDU is succeeded	CE	Communication malfunction between mode exchanger and IDU
UL	Emergency operation DIP switch code of compressor is wrong	CF	Malfunction of multiple main control units

Error Code	Content	Error Code	Content
UE	Charging of refrigerant is invalid	CJ	Address DIP switch code of system is shocking
UF	Identification malfunction of IDU of mode exchanger	CP	Malfunction of multiple wired controller
C0	Communication malfunction between IDU, ODU and IDU's wired controller	CU	Communication malfunction between IDU and the receiving lamp
C1	Communication malfunction between main control and DC-DC controller	Cb	Overflow distribution of IP address
C2	Communication malfunction between main control and inverter compressor driver	Cd	Communication malfunction between mode exchanger and ODU
C3	Communication malfunction between main control and inverter fan driver	Cn	Malfunction of network for IDU and ODU of mode exchanger
C4	Malfunction of lack of IDU	Cy	Communication malfunction of mode exchanger
C5	Alarm because project code of IDU is inconsistent	—	—

Status:

Error Code	Content	Error Code	Content
A0	Unit waiting for debugging	Ay	Shielding status
A2	Refrigerant recovery operation of after-sales	n0	SE operation setting of system
A3	Defrosting	n3	Compulsory defrosting
A4	Oil-return	n4	Limit setting for max. capacity/output capacity
A6	Heat pump function setting	n5	Compulsory excursion of engineering code of IDU
A7	Quiet mode setting	n6	Inquiry of malfunction
A8	Vacuum pump mode	n7	Inquiry of parameters
AH	Heating	n8	Inquiry of project code of IDU
AC	Cooling	n9	Check quantity of IDU on line
AL	Charge refrigerant automatically	nA	Heat pump unit
AE	Charge refrigerant manually	nH	Heating only unit
AF	Fan	nC	Cooling only unit
AJ	Cleaning reminding of filter	nE	Negative code
AP	Debugging confirmation when starting up the unit	nF	Fan model
AU	Long-distance emergency stop	nJ	High temperature prevention when heating
Ab	Emergency stop of operation	nU	Eliminate the long-distance shielding command of IDU
Ad	Limit operation	nb	Bar code inquiry
An	Child lock status	nn	Length modification of connection pipe of ODU

8 Maintenance and Care

Regular check, Maintenance and care should be performed every six months by professional personnel, which will prolong the unit life span. Disconnect the power supply before cleaning and maintenance.

8.1 Outdoor Heat Exchanger

Outdoor heat exchanger is required to be cleaned once every six months. Use vacuum cleaner with nylon brush to clean up dust and sundries on the surface of heat exchanger. Blow away dust by compressed air if it is available. Never use water to wash the heat exchanger.

8.2 Drain Pipe

Regularly check if the drain pipe is clogged in order to drain condensate smoothly.

8.3 Notice before Seasonal Use

- (1) Check if the inlet/outlet of the indoor/outdoor unit is clogged.
- (2) Check if the ground wire is earthed reliably.
- (3) Check if battery of remote wireless controller has been replaced.
- (4) Check if the filter screen has been set soundly.
- (5) After long period of shutdown, open the main power switch 8 hours before operating the unit so as to preheat the compressor crankcase.
- (6) Check if the outdoor unit is installed firmly. If there is something abnormal, please contact the GREE appointed service center.

8.4 Maintenance after Seasonal Use

- (1) Cut off main power supply of the unit.
- (2) Clean filter screen and indoor and outdoor units.
- (3) Clean the dust and sundries on the indoor and outdoor units.
- (4) In the event of rusting, use the anti-rust paint to stop spreading of rust.

8.5 Parts Replacement

Purchase parts from Gree appointed service center or dealer if necessary.

NOTICE During airtight and leakage test, never mix oxygen, ethyne and other dangerous gas into refrigeration circuit. In case of hazard, it's better to use nitrogen or refrigerant to accomplish such test.

9 After-sales Service

In case the air-conditioning unit you bought has any quality problem or you have any inquiry, please contact the local after-sales service agency designated by Gree.

Warranty should meet the following requirements:

- (1) First run of the unit should be operated by professional personnel from Gree appointed service center.
- (2) Only Gree manufactured accessories can be used on the machine.
- (3) All the instructions listed in this manual should be followed.
- (4) Warranty will be automatically invalid if fails to obey any item mentioned above.

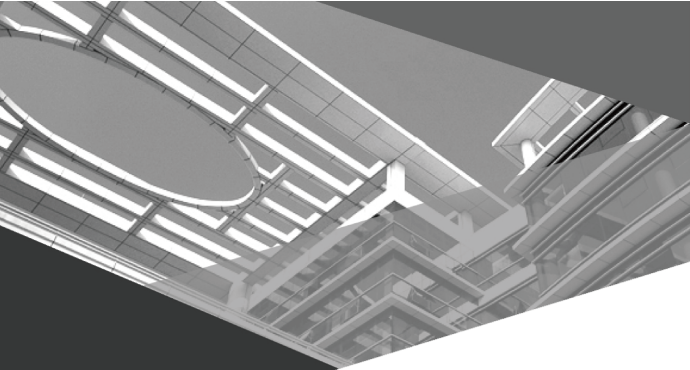

GREE ELECTRIC APPLIANCES, INC. OF ZHUHAI

Add: West Jinji Rd, Qianshan, Zhuhai,Guangdong, China, 519070

Tel: (+86-756) 8522218

Fax: (+86-756) 8669426

E-mail: global@cn.gree.com www.gree.com



600005000652