

A decorative graphic element consisting of a dark gray triangle pointing downwards, partially overlapping a lighter gray triangle pointing upwards.

Owner's Manual

Original Instructions

Receiver JS13

Thank you for choosing this product. Please read this Owner's Manual carefully before operation and retain it for future reference.

If you have lost the Owner's Manual, please contact the local agent or visit www.gree.com or send an email to global@cn.gree.com for the electronic version.

GREE ELECTRIC APPLIANCES, INC. OF ZHUHAI

A large, abstract graphic in the bottom right corner of the page. It features a dark gray triangle pointing downwards, overlapping a lighter gray triangle pointing upwards. Below these triangles is a detailed, grayscale image of a complex mechanical or electrical assembly, possibly a compressor or motor, with various pipes, wires, and components visible.

To Users

Thank you for selecting Gree's product. Please read this instruction manual carefully before installing and using the product, so as to master and correctly use the product. In order to guide you to correctly install and use our product and achieve expected operating effect, we hereby instruct as below:

- (1) This appliance is not intended for use by persons (including children) with reduced physical, sensory or mental capabilities, or lack of experience and knowledge, unless they have been given supervision or instruction concerning use of the appliance by a person responsible for their safety. Children should be supervised to ensure that they do not play with the appliance.
- (2) This instruction manual is a universal manual, some functions are only applicable to particular product. All the illustrations and information in the instruction manual are only for reference, and control interface should be subject to actual operation.
- (3) In order to make the product better, we will continuously conduct improvement and innovation. We have the right to make necessary revision to the product from time to time due to the reason of sales or production, and reserve the right to revise the contents without further notice.
- (4) For personal injury or property loss and damage caused by improper operation such as improper installation and debugging, unnecessary maintenance, violation of related national laws and rules and industrial standard, and violation of this instruction manual, etc., we will bear no liability.
- (5) The final right to interpret for this instruction manual belongs to Gree Electric Appliances, Inc. of Zhuhai.

Contents

1 Safety Notices (Please be sure to abide)	1
2 Notices for Application	2
3 Installation Instructions of Receiver	3
3.1 Dimension and Assembly of Receiver.....	3
3.2 Installation Method	9
4 Introduction to Display	11
4.1 Appearance of Receiver.....	11
4.2 Functions	11
5 Display of Error Codes	12
5.1 Table of Error Codes for Outdoor Unit.....	13
5.2 Table of Error Codes for Indoor Unit	16
5.3 Table of Debugging Codes.....	18
5.4 Table of Status Codes	20

1 Safety Notices (Please be sure to abide)



WARNING: If not abide strictly, it may cause severe damage to the unit or the people.



NOTE: If not abide strictly, it may cause slight or medium damage to the unit or the people.



This sign indicates that the operation must be prohibited. Improper operation may cause severe damage or death to people.



This sign indicates that the items must be observed. Improper operation may cause damage to people or property.



WARNING!

This product can't be installed at corrosive, inflammable or explosive environment or the place with special requirements, such as kitchen. Otherwise, it will affect the normal operation or shorten the service life of the unit, or even cause fire hazard or serious injury. As for such places, please use special products with anti-corrosive or anti-explosion feature.

2 Notices for Application

- ☆ The power supply mode of each indoor unit must be unified power supply.
- ☆ Never install the Receiver in a humid place or a place with direct sunlight.
- ☆ Prevent knocking, throwing, frequent disassembly and assembly of the Receiver.
- ☆ Do not operate the wired controller with wet hands.
- ☆ This product is applicable for multi VRF central air conditioners.
- ☆ Pay attention to the following when matching with multiple VRF units:
 - ① When the priority of system mode is master-slave mode, one indoor unit must be set as master-mode indoor unit (master indoor unit) in a system network, and the other indoor units are slave indoor units.
 - ② When the priority of system mode is master-slave mode, the system mode is subject to the operation mode of the master indoor unit. The master indoor unit can be set to any mode (including automatic mode), and the slave indoor unit cannot be set to the mode that conflicts with the system mode. When the master indoor unit changes mode and cause a conflict between the operation mode of the slave indoor unit and the system operation mode, the operation mode of the slave indoor unit will automatically changes to the system operation mode.
 - ③ The system mode priority is cooling priority, heating priority, first opening priority, second opening priority. The indoor unit can be set to any mode (excluding automatic mode). When the indoor unit operation mode is in

conflict with the system operation mode, the indoor unit will automatically switch to system mode.

- ④ The priority of the system mode defaults to the master-slave mode, and only a specific unit has the priority of other system modes.

3 Installation Instructions of Receiver

3.1 Dimension and Assembly of Receiver

Unit: mm

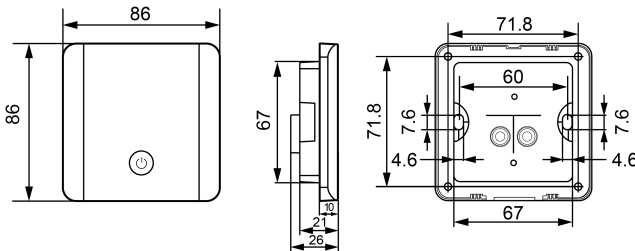

Figure 3-1 Dimension of Receiver

3.1.1 Selection Requirement for Communication Wire

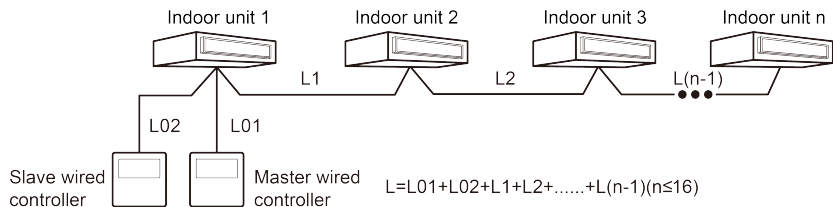

Figure 3-2 Length of Communication Wire

Wire material type	Total length of communication wire between indoor unit and wired controller L (m)	Wire size (mm ²)	Material standard	Remarks
Light/Ordinary polyvinyl chloride sheathed twisted pair cord	$L \leq 250$	2×0.75~2×1.25	GB/T 5023.5-2008	Total length of communication wire can't exceed 250m.
Shielded light/Ordinary polyvinyl chloride sheathed twisted pair cord	$L \leq 250$	2×0.75~2×1.25	GB/T 5023.5-2008	If unit is installed in places with intense magnetic field or strong interference, it is necessary to use shielded wire

NOTES:

- ① If unit is installed in places with intense magnetic field or strong interference, the communication wire of the receiver must be shielded twisted wire.

- ② The communication wire of the receiver must be selected according to this manual. Prohibit selecting the communication wire which doesn't comply with the requirement of this manual.

3.1.2 Installation Requirements

- (1) Never install the receiver in a wet and damp place.
- (2) Never install the receiver in a place with direct sunlight.
- (3) Never install the receiver in a place near high temperature objects or a place where the unit might be splashed by water.
- (4) Never install the receiver in the position where facing the window, so as to avoid interference of neighbor's remote controller with the same model and cause malfunction.
- (5) When installing the receiver, do not block the signal receiving window area to avoid affecting the receiving of remote control signals.

3.1.3 Wiring Requirements

There are four kinds of wiring methods between the receiver and indoor unit network:

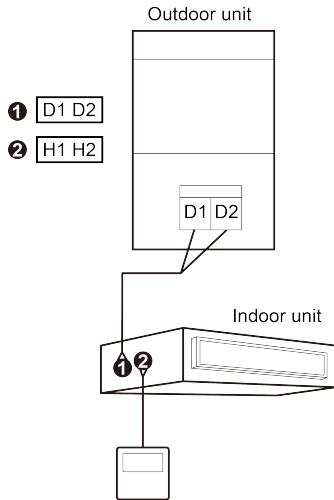

Figure 3-3 One Receiver Controls One Indoor unit

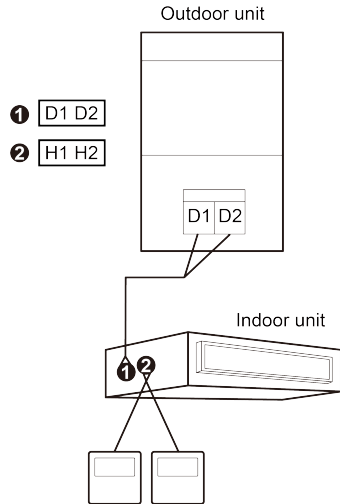

Figure 3-4 One Receiver and One Wired Controllers Control One Indoor unit

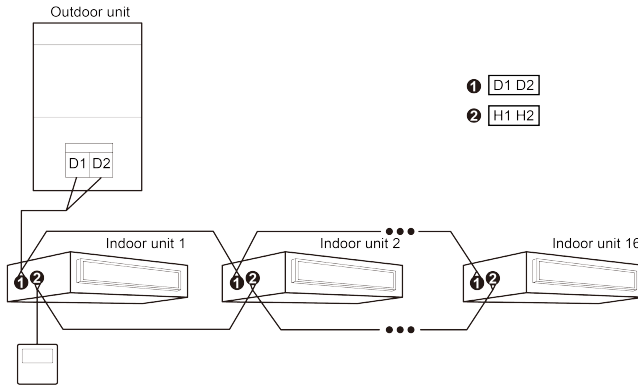

Figure 3-5 One Receiver Controls Several Multi VRF IDUs Simultaneously

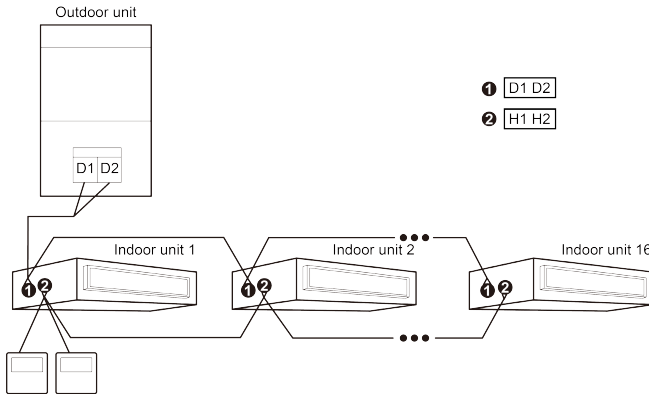

Figure 3-6 One Receiver and One Wired Controller Control Several Multi VRF IDUs Simultaneously

Wiring instructions:

- (1) When the receiver is connected with multi VRF unit, the wiring methods as shown in Figure 3-3, Figure 3-4, Figure 3-5 and Figure 3-6 can be adopted, but please pay attention to the follow:
 - ① When one receiver or one receiver and one wired controller control several indoor units simultaneously, the receiver can connect any one indoor unit, but the connected indoor unit shall be of the same indoor unit series and the connected indoor unit shall be in the same multi VRF system. When it is applied together with the wired controller, please set the indoor unit quantity of group control in the wired controller.
 - ② When the receiver controls several indoor units simultaneously, the settings of all indoor units controlled by it shall be identical.
- (2) In the wiring methods as shown in Figure 3-4, Figure 3-6, there can't be two receivers simultaneously and only one wired controller and one receiver are allowable. The wired controller can be set as master or slave wired controller and the receiver address will switch automatically (no need to set receiver address manually) according to the wired controller address (that is master/slave wired controller). The total quantity of receiver and wired controller can't exceed two.
- (3) The receiver interface is non-polar, but it can't be connected with heavy current.

3.2 Installation Method

- (1) When the indoor unit is installed well, select an installation position for the remote signal receiver according to the size of the connection wire and the installation position of the unit, leaving a groove and buried wire slot to install the remote signal receiver and bury the connection wires;
- (2) Drill holes on the installation wall according to the installation dimension in the middle of the receiver dimension drawing, and then insert expanded plastic into each hole;
- (3) Bury the connection wire and fix the connection wire with the screw at the back of the receiver body;
- (4) If Junction box is reserved, please fix the receiver body in the Junction box with screw M4×25. If Junction box is not reserved, please fix the receiver body directly on the installation position with tapping screw ST3.5×25 PA and then assemble the cover;
- (5) Connect the connection wire to the corresponding position of the unit where connecting the wired controller to complete the installation.

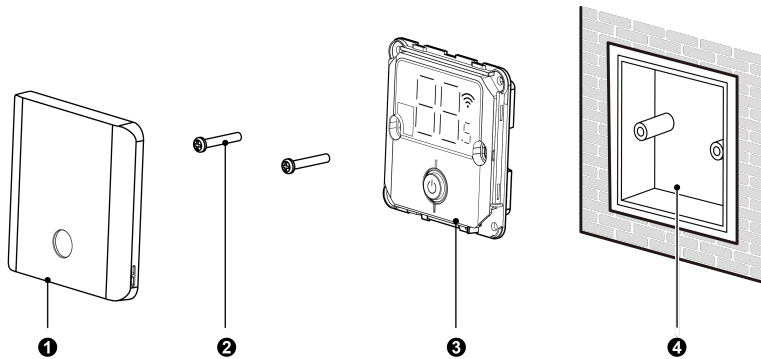

Figure 3-7 Components of Receiver (reserve Junction box for installation)

Table 3.2.1 Introduction of Components (reserve Junction box for installation)

No.	①	②	③	④
Name	Cover	Screw M4×25	Receiver body	Junction box installed inside the wall(Prepared by user)

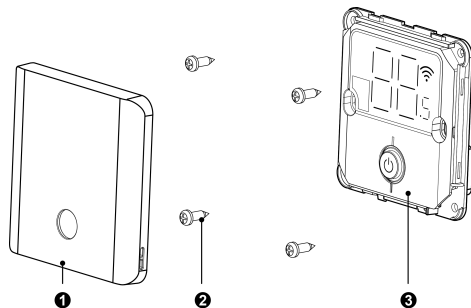

Figure 3-8 Components of Receiver (without Junction box for installation)

Table 3.2.2 Introduction of Components (without Junction box for installation)

No.	①	②	③
Name	Cover	Tapping screw ST3.5×25 PA	Receiver body

4 Introduction to Display

4.1 Appearance of Receiver

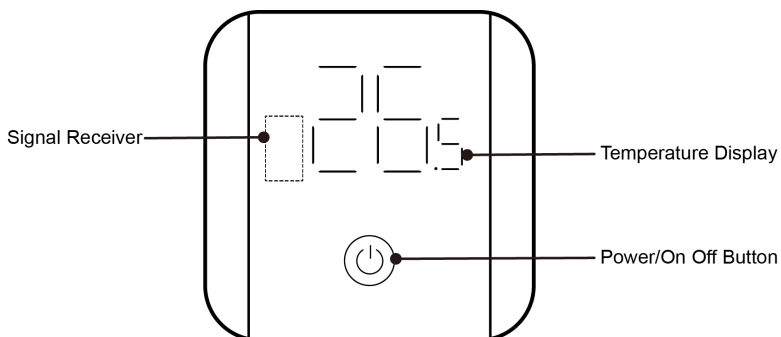

Figure 4-1 Appearance of Receiver

4.2 Functions

- (1) Press “On Off” button to turn on or turn off the unit: when the unit is on, set temperature is displayed; when the unit is off, set temperature is not displayed and the power indicator is displayed.
- (2) Under normal operation, the temperature display area defaults to display set temperature, or set humidity, corresponding error code and debugging code.

When using the remote control to set and display the indoor or outdoor temperature, the temperature display area will display indoor or outdoor temperature for 3s and then switch to display the corresponding set temperature value.

- (3) Under normal operation, when the remote control switches the light on or off, the remote signal receiver will switch between display and black screen. When the lights are off, they all go out. At this time, when the remote control signal is received, it will display normally for 3s and then go out. The light is defaulted to be on after energization.
- (4) Temperature value is displayed in Celsius or Fahrenheit and its unit °C or °F is not displayed.
- (5) When the centralized controller has set partial shielding or full shielding function, if using a remote control to control the receiver, the receiver's buzzer will give out an invalid operation sound (the buzzer quickly responds twice). When the centralized controller has set energy-saving function, if the temperature set by the remote control exceeds the upper limit or lower limit temperature, the buzzer will give out an invalid operation sound (the buzzer responds twice quickly).

5 Display of Error Codes

When error occurs in the system, temperature display window will display error code. When multiple errors occur simultaneously, it will circularly display error codes.

When error occurs, please turn off the unit and ask professional personnel to maintain it.

The following figure refers to the communication error of multi VRF units.

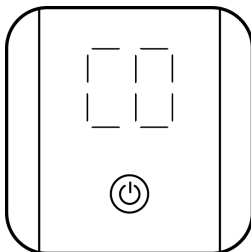

Figure 5-1 Communication Error of Multi VRF Units

5.1 Table of Error Codes for Outdoor Unit

Error Code	Content	Error Code	Content
E0	Outdoor Unit Error	J9	System Pressure Under-Ratio Protection
E1	High Pressure Protection	JA	Protection of Abnormal Pressure
E2	Discharge Low Temperature Protection	JC	Protection of Water Flow Switch
E3	Low Pressure Protection	JL	Protection of Low High-pressure
E4	Excess Discharge Temperature Protection of Compressor	JE	Oil Return Pipe is Blocked
Ed	Low Temperature Protection of Driver Module	JF	Oil Return Pipe is Leaking

Error Code	Content	Error Code	Content
F0	Bad Performance of the Outdoor Mainboard	JJ	Low Water-in Temperature Protection
F1	High Pressure Sensor Error	b1	Outdoor Ambient Temperature Sensor Error
F2	Inlet Tube Temperature Sensor Error of Plate Type Heat Exchanger	b2	Defrosting Temperature Sensor 1 Error
F3	Low Pressure Sensor Error	b3	Defrosting Temperature Sensor 2 Error
F4	Outlet Tube Temperature Sensor Error of Plate Type Heat Exchanger	b4	Subcooler Liquid-out Temperature Sensor Error
F5	Compressor 1 Discharge Temperature Sensor Error	b5	Subcooler Gas-out Temperature Sensor Error
F6	Compressor 2 Discharge Temperature Sensor Error	b6	Gas-liquid Separator Inlet Temperature Sensor Error
F7	Compressor 3 Discharge Temperature Sensor Error	b7	Gas-liquid Separator Outlet Temperature Sensor Error
F8	Compressor 4 Discharge Temperature Sensor Error	b8	Outdoor Humidity Sensor Error
F9	Compressor 5 Discharge Temperature Sensor Error	b9	Heat Exchanger Gas-out Temperature Sensor Error
FA	Compressor 6 Discharge Temperature Sensor Error	bA	Oil-return Temperature Sensor Error
FC	Compressor 2 Current Sensor Error	bH	System Clock Malfunction
FL	Compressor 3 Current Sensor Error	bE	Malfunction of Entry Tube Temperature Sensor of Condenser

Receiver JS13

Error Code	Content	Error Code	Content
FE	Compressor 4 Current Sensor Error	bF	Malfunction of Exit Tube Temperature Sensor of Condenser
FF	Compressor 5 Current Sensor Error	bJ	High and Low Pressure Sensors are Connected Inversely
FJ	Compressor 6 Current Sensor Error	bP	Oil-return 2 Temperature Sensor Error
FP	Malfunction of DC motor	bU	Oil-return 3 Temperature Sensor Error
FU	Compressor 1 Top Temperature Sensor Error	bb	Oil-return 4 Temperature Sensor Error
Fb	Compressor 2 Top Temperature Sensor Error	bd	Air-in Temperature Sensor Error of Subcooler
Fd	Mode Exchanger Outlet Pipe Temperature Sensor Error	bn	Liquid-in Temperature Sensor Error of Subcooler
Fn	Mode Exchanger Inlet Pipe Temperature Sensor Error	by	Water-out Temperature Sensor Error
Fy	Water-in Temperature Sensor Error	P0	Compressor Drive Board Error
J1	Compressor 1 Over-current Protection	P1	Compressor Drive Board Malfunction
J2	Compressor 2 Over-current Protection	P2	Protection of Compressor Drive Board Power Supply
J3	Compressor 3 Over-current Protection	P3	Protection of Compressor Drive Board Module Reset
J4	Compressor 4 Over-current Protection	H0	Error of Fan Drive Board
J5	Compressor 5 Over-current Protection	H1	Malfunction of Fan Drive Board

Error Code	Content	Error Code	Content
J6	Compressor 6 Over-current Protection	H2	Protection of Fan Drive Board Power Supply
J7	4-way Valve Blow-by Protection	GH	PV DC/DC Protection
J8	System Pressure Over-Ratio Protection	FH	Compressor 1 current sensor error

5.2 Table of Error Codes for Indoor Unit

Error Code	Content	Error Code	Content
L0	Indoor Unit Error	dL	Outlet Air Temperature Sensor Error
L1	Indoor Fan Protection	dE	Indoor Unit CO ₂ Sensor Error
L2	E-heater Protection	db	Special Code: Field Debugging Code
L3	Water Full Protection	dn	Swing Assembly Error
L4	Wired Controller Power Supply Error	dy	Water Temperature Sensor Error
L5	Anti-Frosting Protection	y1	Inlet Pipe Temperature Sensor 2 Error
L6	Mode Conflict	y2	Outlet Pipe Temperature Sensor 2 Error
L7	No Master Indoor Unit Error	y3	Middle Tube Temperature Sensor 2 Error
L8	Power Insufficiency Protection	y7	Fresh Air Inflow Temperature Sensor Error

Receiver JS13

Error Code	Content	Error Code	Content
L9	Quantity Of Group Control Indoor Units Setting Error	y8	Indoor Air Box Sensor Error
LA	Indoor Units Incompatibility Error	y9	Outdoor Air Box Sensor Error
LH	Low Air Quantity Warning	yA	IFD Error
LC	Outdoor-Indoor Incompatibility Error	yH	Fresh Air-out Sensor Error
LF	Shunt Valve Setting Error	yC	Air-return Inlet Sensor Error
LJ	Wrong Setting of Function DIP Switch	yL	Air-return Outlet Temperature Sensor Error
LP	Zero-crossing Malfunction of PG Motor	yE	High Liquid Level Switch Error
LU	Inconsistent Branch of Group-controlled Indoor Units in Heat Recovery System	yF	Low Liquid Level Switch Error
Lb	Inconsistency of Group-controlled Indoor Units in Reheat Dehumidification System	o0	Motor Drive Error
Ld	Indoor Fan 2 Error	o1	Low Voltage of IDU Bus Bar
Ln	Lift Panel Return Air Frame Reset Exception	o2	High Voltage of IDU Bus Bar
d1	Indoor Unit PC-Board Error	o3	IDU IPM Module Protection
d3	Ambient Temperature Sensor Error	o4	IDU Startup Failure
d4	Inlet Pipe Temperature Sensor Error	o5	IDU Overcurrent Protection
d5	Malfunction of Middle Tube Temperature Sensor	o6	IDU Current Detective Electric Circuit Error

Error Code	Content	Error Code	Content
d6	Outlet Pipe Temperature Sensor Error	o7	IDU Losing Step Protection
d7	Humidity Sensor Error	o8	IDU Driver Communication Error
d8	Water Temperature Abnormality	o9	Communication Error of IDU Master Controller
d9	Jumper Cap Error	oA	High Temperature of IDU Module
dA	Indoor Unit Hardware Address Error	oC	IDU Charging Circuit Error
dH	Wired Controller PC-Board Error	ob	Temperature Sensor Error of IDU Module
dC	Capacity DIP Switch Setting Error	—	—

5.3 Table of Debugging Codes

Debugging Code	Content	Debugging Code	Content
U2	Outdoor Unit Capacity Code/Jumper Cap Setting Error	C0	Communication between indoor unit and outdoor unit and the communication between indoor unit and wired controller have malfunction
U3	Phase Sequence Protection of Power Supply	C1	Communication error of expansion board
U4	Protection of Lack of Refrigerant	C2	Communication error between master control and inverter compressor drive

Receiver JS13

Debugging Code	Content	Debugging Code	Content
U5	Wrong Address of Compressor Drive Board	C3	Communication error between master control and inverter fan motor drive
U6	Valve Abnormal Alarm	C4	Error of Lack of Indoor Unit
U7	Grid DRED0 Response Protection	C5	Alarm of Indoor Unit Project Number Collision
U8	Indoor Unit Tube Malfunction	C6	Alarm of Wrong Number of Outdoor Unit
U9	Outdoor Unit Tube Malfunction	C7	Mode Exchanger Communication Error
UA	Overvoltage Protection of DC Bus Bar in Power Grid Side	CH	Rated capacity is too high
UH	Undervoltage Protection of DC Bus Bar in Power Grid Side	CC	No master control unit error
UC	Master indoor unit is successfully set	CL	Rated capacity is too low
UL	Emergency Operation DIP switch setting of the compressor is wrong	CE	Communication Failure Between Mode Exchanger and Indoor Unit
UE	Refrigerant Charging is ineffective	CF	Error of Multiple Master Indoor Unit
UF	Indoor Unit Identification Error of Mode Exchanger	CJ	System addresses is incompatible
UJ	PV module F0 protection	CP	Error of Multiple Master Wired Controller
UP	Protection shutdown error of thermal storage module	CU	Communication Error between Indoor Unit and Remote Receiver

Debugging Code	Content	Debugging Code	Content
UU	Electronic expansion valve leak error of thermal storage module	Cb	Outflow of Units IP Address
Ub	Protection without shutdown error of thermal storage module	Cd	Communication Failure Between Mode Exchanger and Outdoor Unit
Ud	Grid-connection driver board error	Cn	Indoor and Outdoor Network Error of Mode Exchanger
Un	Communication error between grid-connection driver board and master controller	Cy	Communication Error of No Master in Mode Exchanger
Uy	PV module overheating protection	—	—

5.4 Table of Status Codes

Status Code	Content	Status Code	Content
A0	Unit is waiting for debugging	Ay	Shielding status
A1	Check the compressor operation parameters	n3	Compulsory defrosting
A2	After-sales Refrigerant Reclaim	q5	Setting of ordinary units and high sensible heat units
A3	Defrosting	q7	Select degree Celsius or Fahrenheit
A4	Oil return	q8	Discharge low temperature protection revision value b
A5	Online Testing	q9	Setting of defrosting mode

Receiver JS13

Status Code	Content	Status Code	Content
A8	Vacuum-pumping Mode	qL	Setting of static pressure
A9	Operate in Setback Function	qE	EVI Operating Mode
AH	Heating	qF	System compulsory cooling mode
AC	Cooling	qP	PV GMV Unit export area setting
AF	Fan	qU	Grid voltage system configuration
AJ	Filter Clean Reminder	qb	Anti-condensation temperature setting
AU	Remote Urgent Stop	qd	Setting of target degree of super-cooling of ODU
Ab	Emergency Stop	qn	PV grid-connected settings
Ad	Operation Restriction	qy	Working mode of compressor heating belt
An	Lock status	CL	Self-clean (displayed when self-clean is turned on manually)
FA	Displayed when the receiver connects with fresh air indoor unit	—	—



GREE ELECTRIC APPLIANCES, INC. OF ZHUHAI

Add: West Jinji Rd, Qianshan, Zhuhai, Guangdong, China, 519070

Tel: (+86-756) 8522218

Fax: (+86-756) 8669426

E-mail: global@cn.gree.com www.gree.com



600005064248