



Owner's Manual

Original Instructions

Commercial Air Conditioners

Multi Variable Air Conditioners Ducted Type Indoor Unit

Models:

GMV-ND30PLS/C-T(U)

GMV-ND36PLS/C-T(U)

GMV-ND42PLS/C-T(U)

GMV-ND48PLS/C-T(U)

Thank you for choosing commercial air conditioners. Please read this Owner's Manual carefully before operation and retain it for future reference.

If you have lost the Owner's Manual, please contact the local agent or visit www.gree.com or send an email to global@cn.gree.com for the electronic version.

GREE ELECTRIC APPLIANCES, INC. OF ZHUHAI

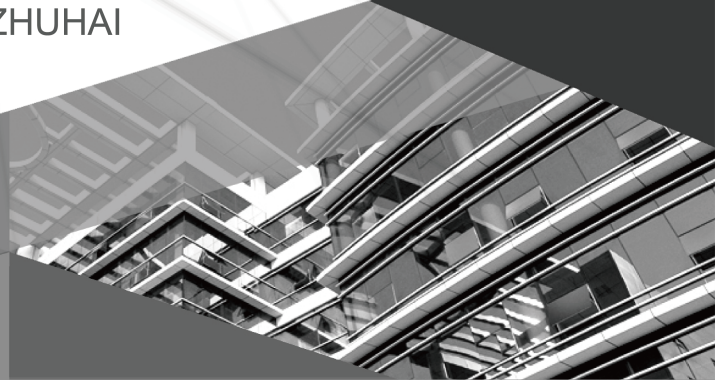

Preface

For correct installation and operation, please read all instructions carefully. Before reading the instructions, please be aware of the following items:

⚠ DANGER	If not abide them strictly, it may cause severe damage to the unit or the people.
⚠ WARNING	If not abide them strictly, it may cause slight or medium damage to the unit or the people.
⚠ CAUTION	This sign indicates that the items must be prohibited. Improper operation may cause severe damage or death to people.
NOTICE	This sign indicates that the items must be observed. Improper operation may cause damage to people or property.

⚠ WARNING	
(1)	Instructions for installation and use of this product are provided by the manufacturer.
(2)	Installation must be performed in accordance with the requirements of NEC and CEC by authorized personnel only.
(3)	For the safe operation of this unit, please read and follow the instructions carefully.
(4)	During operation, total capacity of indoor units should not exceed the total capacity of outdoor units. Otherwise, poor effect of cooling or heating may result.
(5)	Direct operators or maintainers should well keep this manual.
(6)	If this unit fails to operate normally, please contact our service center as soon as possible and provide the following information: 1) Content on the nameplate (model number, cooling capacity, production codex-factory date). 2) Malfunction details (before and after the malfunction occurs).
(7)	Each unit has been strictly tested and proved to be qualified before ex-factory. In order to prevent units from being damaged or operating normally because of improper disassembly, please do not disassemble the unit by yourself. If you need to disassemble and check units, please contact our service center. We will send specialists to guide the disassembly.
(8)	All graphics in this manual is only for your reference. For sales or production reasons, these graphics are subject to change by manufacturer without prior notice.

User Notice

- This appliance is not intended for use by persons (including children) with reduced physical, sensory or mental capabilities, or lack of experience and knowledge, unless they have been given supervision or instruction concerning use of the appliance by a person responsible for their safety. Children should be supervised to ensure that they do not play with the appliance.
- DISPOSAL: Do not dispose this product as unsorted municipal waste. Collection of such waste separately for special treatment is necessary.

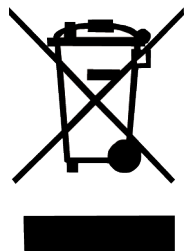

Exception Clauses

Manufacturer will bear no responsibilities when personal injury or property loss is caused by the following reasons:

- (1) Damage the product due to improper use or misuse of the product;
- (2) Alter, change, maintain or use the product with other equipment without abiding by the instruction manual of manufacturer;
- (3) After verification, the defect of product is directly caused by corrosive gas;
- (4) After verification, defects are due to improper operation during transportation of product;
- (5) Operate, repair, maintain the unit without abiding by instruction manual or related regulations;
- (6) After verification, the problem or dispute is caused by the quality specification or performance of parts and components that produced by other manufacturers;
- (7) The damage is caused by natural calamities, bad using environment or force majeure.

Contents

1 Safety Precautions	1
2 Product Introduction	2
2.1 Names of Key Components.....	2
2.2 Rated Working Condition.....	2
3 Preparations for Installation	2
3.1 Standard Fittings	2
3.2 Location for Installation.....	3
3.3 Requirements for Communication Line	3
3.4 Electric Installation.....	4
4 Installation Instructions	5
4.1 Installation of Indoor Unit.....	5
4.2 Refrigerant Pipe Connection	7
4.3 Drainage Pipe Installation and Drainage System Testing.....	8
4.4 Installation of Air Duct.....	11
4.5 Installation of Wired Controller	13
5 Wiring Work	13
5.1 Connection of Wire and Patch Board Terminal.....	14
5.2 Power Cord Connection	14
5.3 Connection of Communication Wire between Indoor Unit and Outdoor Unit (or indoor unit)	15
5.4 Connect Communication Wire of Wired Controller.....	16
5.5 Illuminate for Connection of Wired Controller and Indoor Units Network	16
6 Setting of External Static Pressure	17
7 Routine Maintenance	18
7.1 Cleaning of Filter	18
7.2 Maintenance before the Seasonal Use	18
7.3 Maintenance after the Seasonal Use	18
8 The Table of Error Codes for Indoor Unit	18
9 Troubleshooting	19

1 Safety Precautions

WARNING

- (1) This product can't be installed at corrosive, inflammable or explosive environment or the place with special requirements, such as kitchen. Otherwise, it will affect the normal operation or shorten the service life of the unit, or even cause fire hazard or serious injury. As for the above special places, please adopt special air conditioner with anti-corrosive or anti-explosion function.
- (2) Follow this manual to complete the installation work. Please read this manual carefully before turning on or repairing the unit.
- (3) Installation should be conducted by the dealer or qualified personnel. Please do not attempt to install the air conditioner by yourself. Improper installation may lead to water leakage, electric shock or fire hazard, etc.
- (4) Before installation, please check whether the power supply is complied with that specified on the nameplate and check the safety of the power supply.
- (5) The air conditioner must be grounded reliably for avoiding electric shock. Please do not connect the earthing wire to gas pipe, water pipe, lightning rod or telephone line.
- (6) Be sure to use special accessories and parts for installation to prevent water leakage, electric shock and fire hazard, etc.
- (7) If refrigerant leakage happens, please ventilate the room immediately.
- (8) Diameter of power cord should be large enough. The damaged power cord and connection wire must be replaced with special cables.
- (9) When the power cord is connected, please fix the electric box cover properly to avoid safety accidents.
- (10) Never fail to comply with the nitrogen-charging welding process. Do charge nitrogen when welding the pipes.
- (11) Never short circuit or cancel the pressure switch to prevent unit damage.
- (12) As for the unit controlled by the wired controller, connect the wired controller well firstly and then energize the unit; otherwise, the unit can't operate normally.
- (13) When installation is finished, please check whether the drainage pipes, pipelines and electric wires are connected correctly to avoid water leakage, refrigerant leakage, electric shock or fire, etc.
- (14) Do not insert fingers or objects into air outlet or air return grille.
- (15) Open the door and window frequently to keep good ventilation for avoiding oxygen deficit when gas heater or oil heater is used in the room.
- (16) Never plug in or unplug the power plug directly to turn on or turn off the air conditioner.
- (17) Once the air conditioner is turned on, it can be turned off only after it has operated for 5min at least; otherwise, it will affect the oil return of compressor.
- (18) Do not allow children to operate this air conditioner.
- (19) Do not operate this air conditioner with wet hands.
- (20) The air conditioner can be cleaned only when it has been turned off and the power has been cut off; otherwise, it may cause electric shock or injury.
- (21) Never spray or flush water towards the air conditioner; otherwise, malfunction or electric shock may happen.
- (22) Do not expose the air conditioner to the moist or corrosive environment.
- (23) Put through the power 8 hours in advance before operation. Do not cut off the power when the air conditioner stops operation for only about one night (protect the compressor).
- (24) Volatile liquid, such as diluent or gasoline, will damage the appearance of air conditioner. Only soft dry cloth and wet cloth dipped with neutral detergent can be used to clean the outer case of air conditioner.
- (25) Under cooling mode, please don't set the room temperature too low; keep the temperature difference between indoor and outdoor within 5°C (41°F).
- (26) If there are any abnormal circumstances (such as burning smell, etc.), please turn off the unit and cut off the main power supply immediately, and then contact Gree appointed service center. If those abnormal circumstances still exist, the unit may be damaged and it may lead to electric shock or fire hazard.
- (27) Do not repair the unit by yourself. Wrong maintenance may cause electric shock or fire hazard. Please contact Gree appointed service center for help.

Any personal injury or property loss caused by improper installation, improper debug, unnecessary repair or not following the instructions of this manual should not be the responsibility of Gree Electric Appliances, Inc. of Zhuhai.

2 Product Introduction

2.1 Names of Key Components

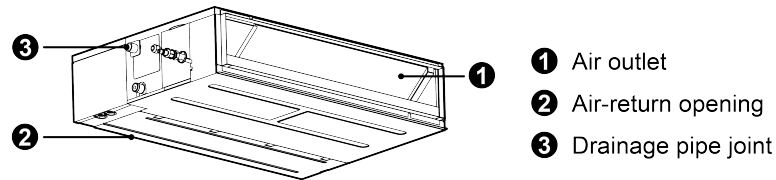

Fig.2.1.1

2.2 Rated Working Condition

—	Indoor Side Condition		Outdoor Side Condition	
	Dry Bulb Temp °C(°F)	Wet Bulb Temp °C(°F)	Dry Bulb Temp °C(°F)	Wet Bulb Temp °C(°F)
Rated Cooling	26.7(80.0)	19.4(67.0)	35(95.0)	23.9(75.0)
Rated Heating	21.1(70.0)	15.6(60.0)	8.3(47.0)	6.1(43.0)

3 Preparations for Installation

NOTICE

Product graphics are only for reference. Please refer to actual products. Unspecified measure unit is mm(inch).

3.1 Standard Fittings

Please use the supplied standard fittings listed below as instructed.

No.	Name	Appearance	Q'ty	Usage
1	Wired Controller		1	To control the indoor unit
2	Drain Hose Assembly		1	To connect with the hard PVC drain pipe
3	Union nut		1	To connect the exit tube
4	Corrugated pipe		1	To be used for connecting the refrigerant pipe
5	M10×8 Nut with Washer		4	To be used together with the hanger bolt for installing the unit.
6	M10 Nut (M10×8.4 Nut)		4	To be used together with the hanger bolt for installing the unit.
7	M10 Washer (Spring Washer M10×2.6)		4	To be used together with the hanger bolt for installing the unit.
8	Insulation		2	To insulate the gas/liquid pipe
9	Sponge		2	To insulate the drain pipe
10	Fastener		8	To fasten the sponge
11	Packing collet (installation cardboard)	—	1	To drill hole on the ceiling

3.2 Location for Installation

- (1) The appliance shall not be installed in the laundry.
- (2) The top holder must be strong enough to support unit's weight.
- (3) Drain pipe can drain water out easily.
- (4) There is no obstacle at inlet or outlet. Please ensure good air circulation.
- (5) In order to make sure the space for maintenance, please install the indoor unit according to the dimension described below.
- (6) Keep the unit away from heating source, inflammable gas or smoke.
- (7) This is a concealed ceiling type unit.
- (8) Indoor unit, outdoor unit, power cord and electric wire should stay at least 1m (39-3/8inch) from the TV set and radio. Otherwise, these electrical appliances may have image interference and noise. (Even if the distance is 1m (39-3/8inch), when there is strong electric wave, noise may still occur.)

Unit: mm(inch)

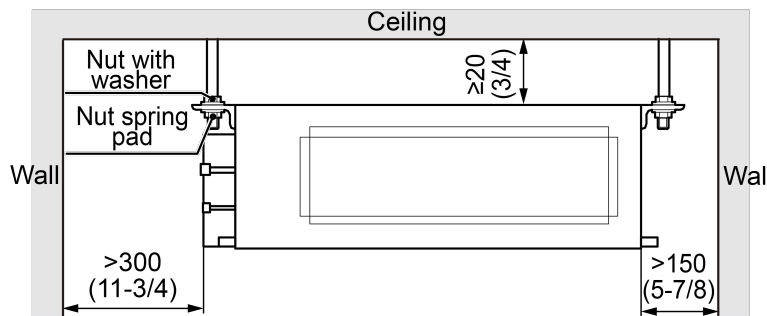

Fig.3.2.1

NOTICE
(1) The unit shall be installed in accordance with national standards or local regulations.
(2) Only qualified personnel can carry out installation work, please contact with local dealer before installation.
(3) Make sure all the installation work completed before energizing.

3.3 Requirements for Communication Line

NOTICE

If air conditioner used under strong electronic-magnetic interference circumstance, STP (shielded twisted pair) communication cable must be adopted.

3.3.1 Select Communication Line for Indoor Unit and Wired Controller

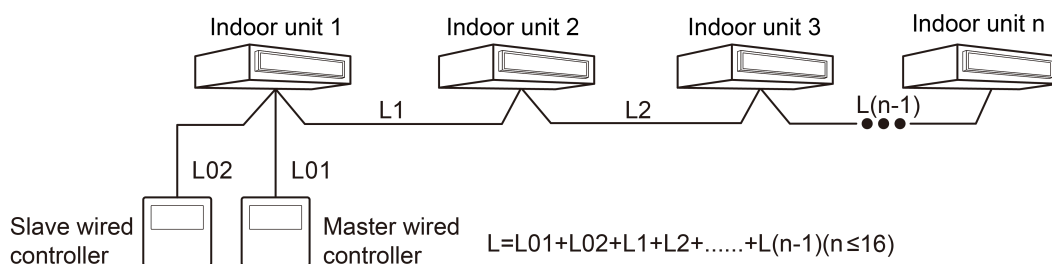

Fig.3.3.1

Multi Variable Air Conditioners Ducted Type Indoor Unit

Material type	Total length of communication line between indoor unit and wired controller L	Numbers × size	Remarks
Light/Ordinary polyvinyl chloride sheathed cord.	$L \leq 250\text{m}$ ($L \leq 820\text{-}1/5\text{ft.}$)	$2 \times \text{AWG}18 \sim 2 \times \text{AWG}16$	<ol style="list-style-type: none"> Total length of communication line can't exceed 250m (820-1/5ft.). The cord shall be Circular cord (the cores shall be twisted together). If unit is installed in places with intense magnetic field or strong interference, it is necessary to use shielded wire.

3.3.2 Select Communication Line for Indoor Unit and Outdoor Unit

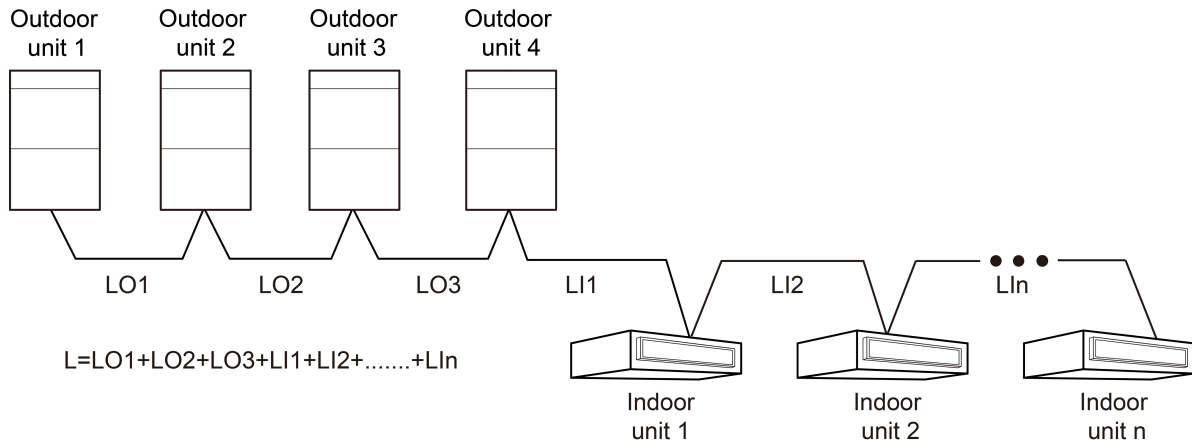

Fig.3.3.2

Material Type	Total Length L of Communication Cable between Indoor Unit and Indoor (Outdoor) Unit	Numbers × size	Remarks
Light/Ordinary polyvinyl chloride sheathed cord.	$L \leq 1000\text{m}$ ($L \leq 3280\text{-}5/6\text{ft.}$)	$\geq 2 \times \text{AWG}18$	<ol style="list-style-type: none"> If the wire diameter is enlarged to $2 \times \text{AWG}16$, the total communication line length can reach 1500 m (4921-1/4ft.). The cord shall be Circular cord (the cores shall be twisted together). If unit is installed in places with intense magnetic field or strong interference, it is necessary to use shielded wire.

3.4 Electric Installation

Models	Power Supply	MCA(A)	MOP(A)
GMV-ND30PLS/C-T(U)	208/230V-1ph-60Hz	3.0	15
GMV-ND36PLS/C-T(U)		3.0	15
GMV-ND42PLS/C-T(U)		3.0	15
GMV-ND48PLS/C-T(U)		3.0	15

NOTICE

- Use copper wire only as unit's power cord. Operating temperature should be within its rated value.
- If the power cord is more than 15m (49-1/4 ft.) long, please increase properly the sectional area of power cord to avoid overload, which may cause accident.
- Above selection requirements: Power cord size is based on BV single-core wire (2~4pc) at 40°C (104°F) Ambient temperature when laying across plastic pipe. Air switch is D type and used at 40°C (104°F). If actual installation condition varies, please lower the capacity appropriately according to the specifications of power cord and air switch provided by manufacturer.
- Install cut-off device near the unit. The minimum distance between each stage of cut-off device should be 3mm (1/8inch) (The same for both indoor unit and outdoor unit).

4 Installation Instructions

NOTICE

This series duct type unit is only for one room.

4.1 Installation of Indoor Unit

4.1.1 Outline Dimension and Installation Spots

Equip with an inspection hatch after lifting the unit. For the convenience of maintenance, the service port should be on one side of the electric box and below unit's lower level.

Below are the outline dimensions applicable to indoor units of GMV-ND30PLS/C-T(U) ~ GMV-ND48PLS/C-T(U).

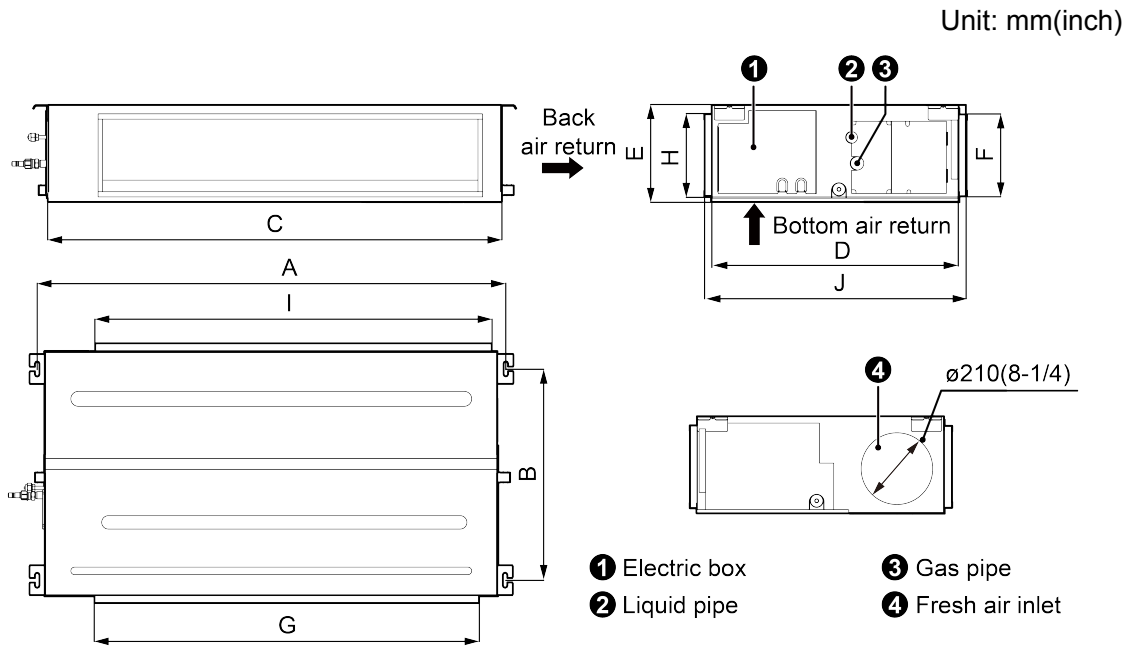

Fig.4.1.1

Below are dimensions of A, B, C, etc. for different models:

Unit: mm(inch)

Model	A	B	C	D	E	F	G	H	I
GMV-ND30PLS/C-T(U)	1379 (54-5/16)	565 (22-1/4)	1340 (52-3/4)	655 (25-13/16)	260 (10-1/4)	207 (8-1/8)	1153 (45-3/8)	220 (8-11/16)	1188 (46-3/4)
GMV-ND36PLS/C-T(U)									
GMV-ND42PLS/C-T(U)									
GMV-ND48PLS/C-T(U)									

4.1.2 Suspend the indoor unit

(1) Drill bolt holes and install bolts

- 1) Stick the reference cardboard on the installation position; drill 4 holes according to the hole site on the cardboard as shown in Fig.4.1.2; diameter of drilling hole is according to the diameter of expansion bolt and the depth is 60-70mm(2-3/8~2-3/4inch), as shown in Fig.4.1.3.

Unit: mm(inch)

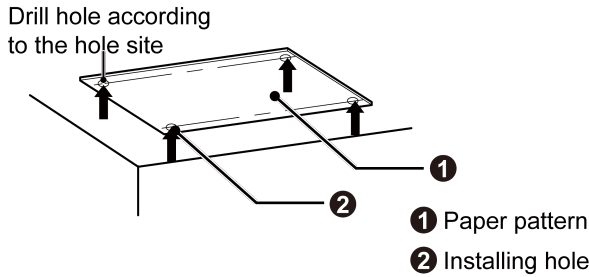

Fig.4.1.2

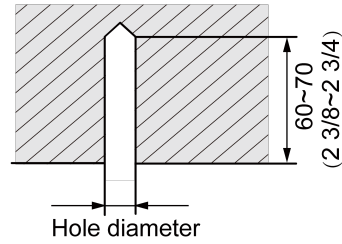

Fig.4.1.3

- 2) Insert the M10 expansion bolt into the hole and then knock the nail into the bolt, as shown in Fig.4.1.4.

NOTICE

The length of bolt depends on the installation height of the unit, bolts are field supplied.

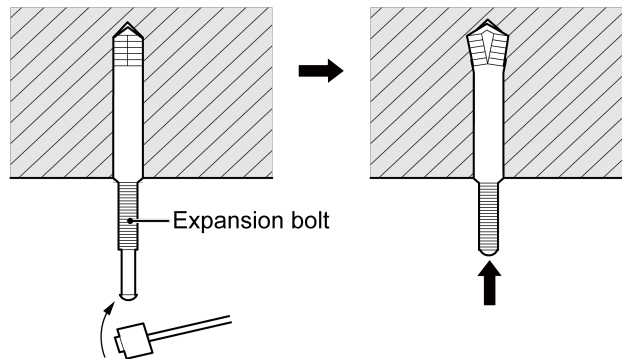

Fig.4.1.4

(2) Install the indoor unit temporarily

Assemble suspension bolt on the expansion bolt, attach the hanger bracket to the suspension bolt. Be sure to fix it securely by using a nut and washer from upper and lower sides of the hanger bracket. The washer fixing plate will prevent the washer from falling.

Unit: mm(inch)

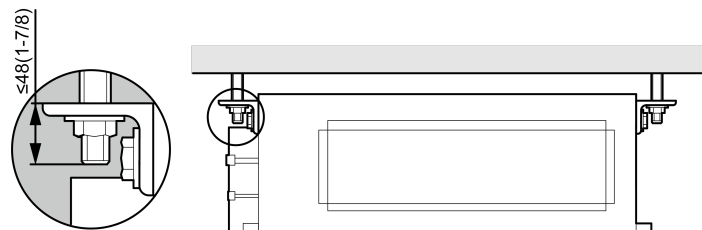

Fig.4.1.5

NOTICE

- ① Before operation, please prepare all pipelines (connection pipe, drainage hose) and wires (connection wire for wired controller, connection wire for indoor unit).
- ② When drilling holes on ceiling (air return outlet or air outlet), you may need to reinforce the ceiling to prevent vibration. For details, please consult with user or builder.
- ③ If the strength of the ceiling is not good, please install a beam bracket, and then put the unit on the beam bracket.
- (3) Adjust the unit to the right position.
- (4) Check the level of the unit

After the indoor unit is installed, remember to check the horizontal status of the whole unit. It should be horizontal from front to back and slant 1% from left to right, following the drainage direction.

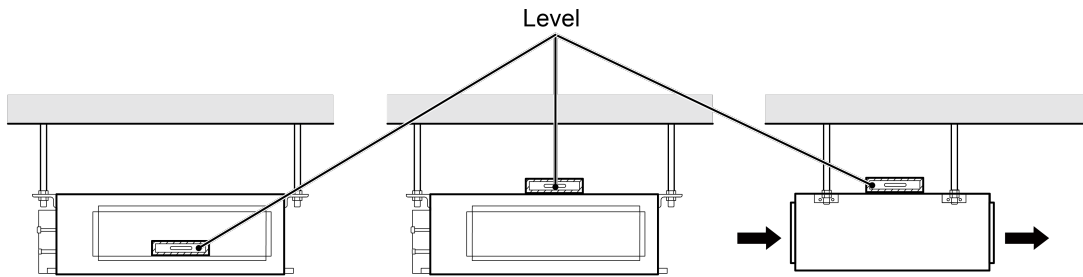

Fig.4.1.6

- (5) Remove the washer locating plate and then tighten the nut on it.

4.2 Refrigerant Pipe Connection

- (1) Aim the flaring port of copper pipe at the center of screwed joint and then tighten the flaring nut with hand as shown in Fig.4.2.1.
- (2) Tighten the flaring nut with torque wrench.

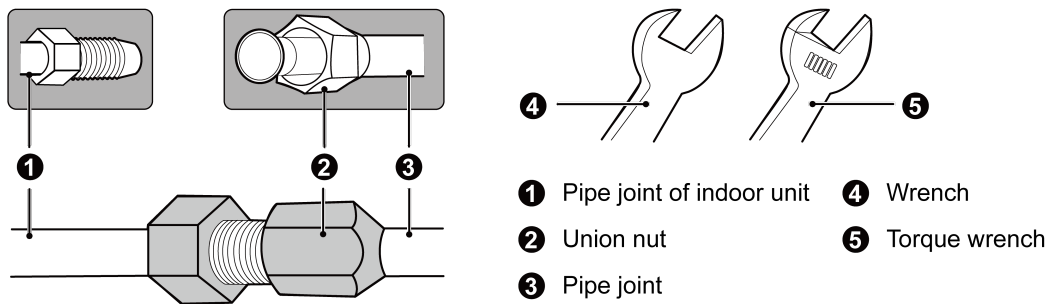

Fig.4.2.1

Torque for tightening nut

Pipe diameter mm(inch)	Torque(N·m)
6.35(1/4)	15~30
9.52(3/8)	35~40
12.7(1/2)	45~50
15.9(5/8)	60~65
19.05(3/4)	70~75

- (3) Use pipe bend when bending the pipe and the bending angle should not be too small.
- (4) Wrap the connection pipe and joint with sponge and then tie them firmly with tape.

4.3 Drainage Pipe Installation and Drainage System Testing

4.3.1 Notice for Installation of Drain Pipe

- (1) It is not allowed to connect the condensate drain pipe into waste pipe or other pipelines which are likely to produce corrosive or peculiar smell to prevent the smell from entering indoors or corrupt the unit.
- (2) It is not allowed to connect the condensate drain pipe into rain pipe to prevent rain water from pouring in and cause property loss or personal injury.
- (3) Condensate drain pipe should be connected into special drain system for air conditioner.
- (4) The drainage pipe should be short and the gradient downwards should be at least 1%~2% in order to drain condensation water smoothly.
- (5) The diameter of drainage hose should be bigger or equal to the diameter of drainage pipe joint.
- (6) Install drainage pipe according to the following Fig. and arrange insulation to the drainage pipe. Improper installation may lead to water leakage and damp the furniture and other things in the room.
- (7) You can buy normal hard PVC pipe used as the drainage pipe. During connection, insert the end of PVC pipe into the drainage hole and then tighten it with drainage hole and wire binder. Can't connect the drainage hole and drainage hole with glue.
- (8) When the drainage pipelines are used for several units, the position of pipeline should be about 100mm(4inch) lower than the drainage port of each unit. In this case, thicker pipes should be applied.

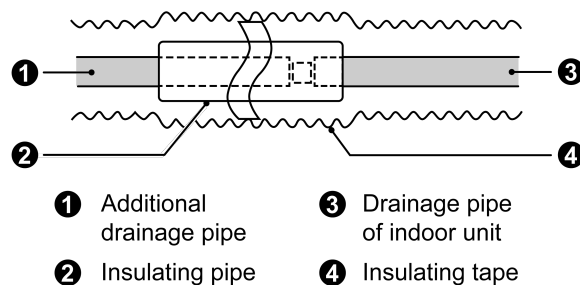

Fig.4.3.1

4.3.2 Drainage pipe installation

- (1) Insert the drain hose into the drain hole and tighten it with tapes, as shown in Fig.4.3.2. Model with water pump will be provided with drain hose, while other models please prepare the drain hose by yourself.
- (2) Tighten the pipe clamp, with the distance between screw nut and hose smaller than 4mm (3/16inch).

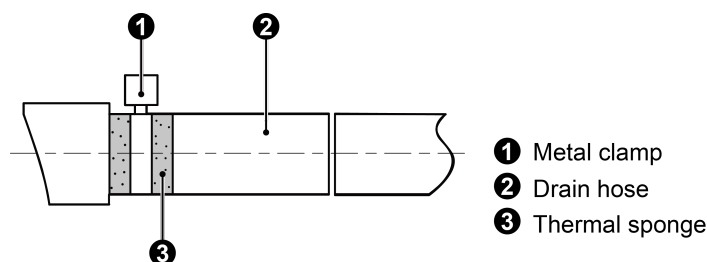

Fig.4.3.2

- (3) Use sealing plate to make the pipe clamp and hose insulated, as shown in Fig.4.3.3.

Unit: mm(inch)

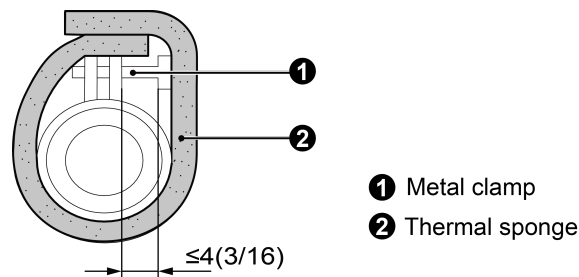

Fig.4.3.3

- (4) When connecting several drain pipes, follow the instruction as indicated in Fig.4.3.4. Choose the drain collecting pipe that matches with unit capacity.

Unit: mm(inch)

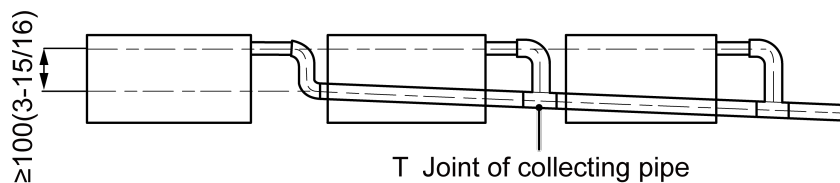

Fig.4.3.4

- (5) Install the trap as shown in following Fig.4.3.5.

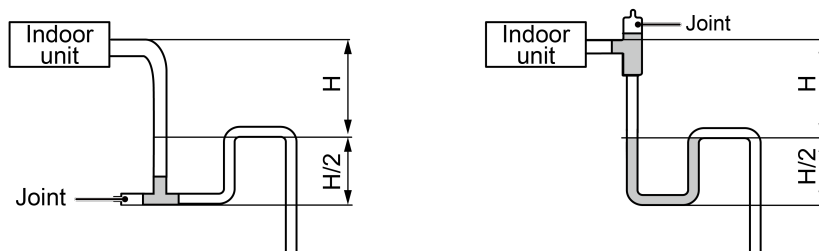

Fig.4.3.5

- (6) Install one trap for each unit.
- (7) Convenience for cleaning trap in the future should be considered when installing it.
- (8) The horizontal pipe can be connected to vertical pipe in the same level; please select the connection way as shown in following Fig.

No.1: Connection of drainage pipe joints (Fig.4.3.6).

No.2: Connection of downspout elbow (Fig.4.3.7).

No.3: Inserting pipe connection (Fig.4.3.8).

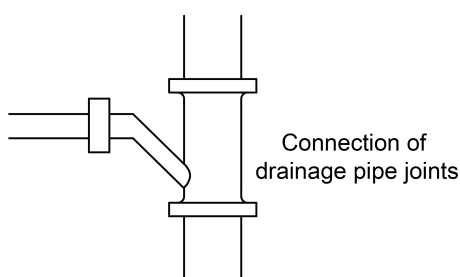

Fig.4.3.6

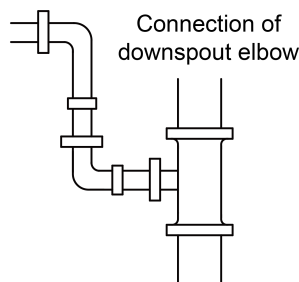

Fig.4.3.7

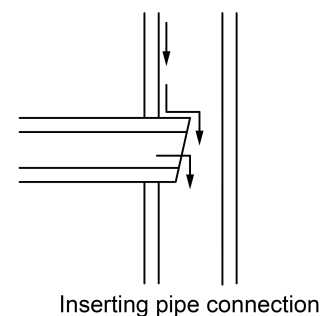

Fig.4.3.8

- (2) During the test, please carefully check the drainage joint, make sure no any leakage occur.
- (3) It is strongly recommended to do the drain test before ceiling decoration.

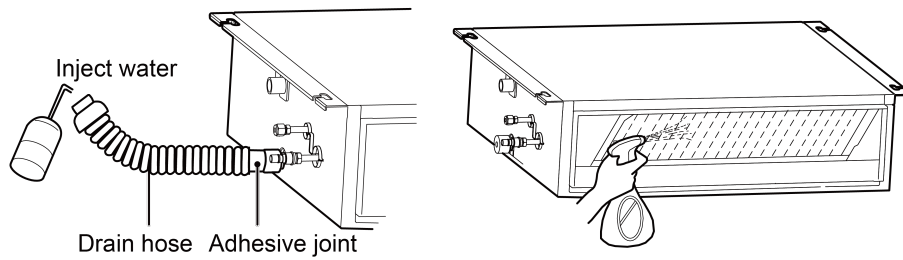

Fig.4.3.11

4.4 Installation of Air Duct

NOTICE

- ① There should be insulating layer on air-out duct, air-return duct and fresh air duct to avoid heat loss and moisture. Adhere a nail on the air duct and then add thermal sponge with a layer of tin. Fasten it with a nail cover and then seal the junction with tin tapes. You can also use other materials that have good insulation quality.
- ② Each air-out duct and air-return duct should be fixed on a pre-made board with iron frame. The junction of air duct should be well-sealed in order to prevent air leakage.
- ③ The design and construction of air duct should comply with national requirements.
- ④ The edge of air-return duct is suggested to be more than 150mm (5-7/8inch) away from the wall. Add a filter to the air-return opening.
- ⑤ Please consider noise-damping and vibration damping for the design and construction of air duct. Besides, noise source must be away from people. For instance, do not have the air-return opening installed on top of the user (offices, rest area, etc.).

4.4.1 Installation of Air-out Duct

(1) Installation of the Rectangular Duct

- ① Hanger rod
- ② Return air duct
- ③ Canvas duct
- ④ Return air inlet
- ⑤ Static pressure box
- ⑥ Filter
- ⑦ Main supply air duct
- ⑧ Supply air outlet

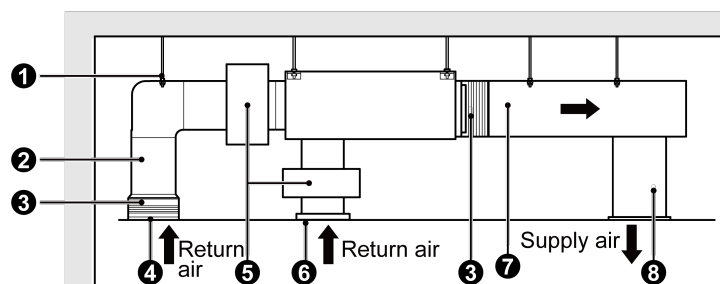

Fig.4.4.1

(2) Installation of Circular Duct

- ① Return air duct
- ② Canvas duct
- ③ Return air blinds
- ④ Hanger rod
- ⑤ Supply air outlet
- ⑥ Transition pipe
- ⑦ Supply air duct
- ⑧ Diffuser
- ⑨ Diffuser connector

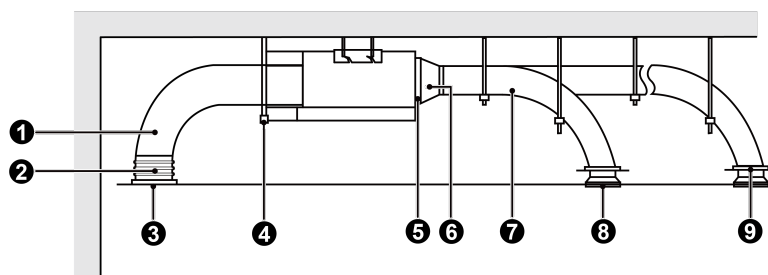

Fig.4.4.2

4.4.2 Shape and Size of Air Outlet and Air-return Opening

Range of Capacity GMV-ND30PLS/C-T(U) ~ GMV-ND48PLS/C-T(U)

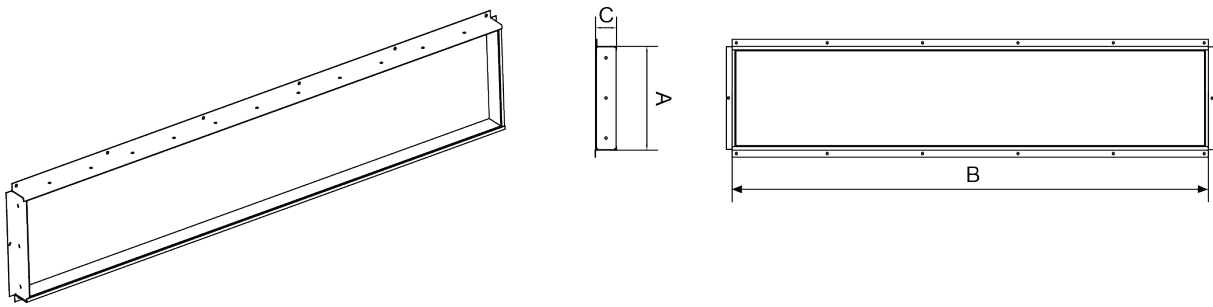

Fig.4.4.3 Air Outlet

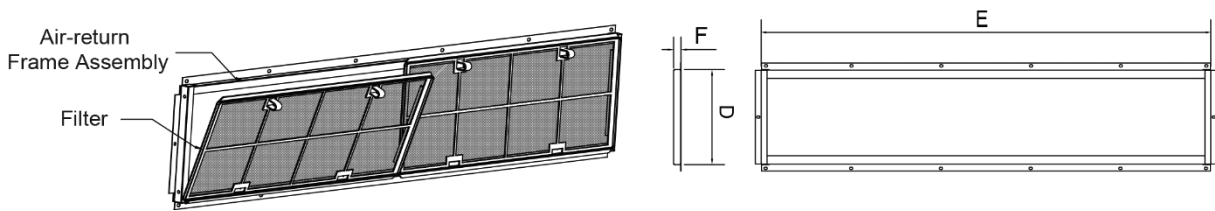

Fig.4.4.4 Air-return Opening

Unit: mm(inch)

Model	Size of Air Outlet			Size of Air-return Opening		
	A	B	C	D	E	F
GMV-ND30PLS/C-T(U)	207(8-1/8)	1153(45-3/8)	40(1-9/16)	1188(46-3/4)	220(8-11/16)	22(7/8)
GMV-ND36PLS/C-T(U)						
GMV-ND42PLS/C-T(U)						
GMV-ND48PLS/C-T(U)						

4.4.3 Installation of the Return Air Duct

- (1) The default installation location of the rectangular flange is at the back and the return air cover plate is at the bottom, as shown in Fig.4.4.5.

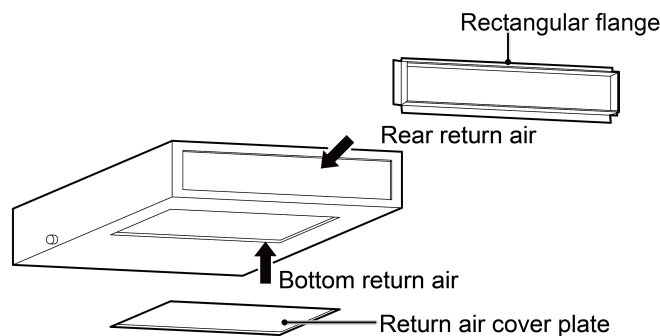

Fig.4.4.5

- (2) If the bottom return air is desired, just change the place of the rectangular flange and the return air cover plate.
- (3) Connect one end of the return air duct to the return air outlet of the unit by rivets and the other to the return air louver. For the sake of the convenience to freely adjust the height, a cutting of canvas duct will be helpful, which can be reinforced and folded by 8# iron wire.
- (4) More noise is likely to be produced in the bottom return air mode than the rear return air mode, so it is suggestive to install a silencer and a static pressure box to minimize the noise.

- (5) The installation method can be chosen with considering the conditions of the building and maintenance etc., as shown in Fig.4.4.6.

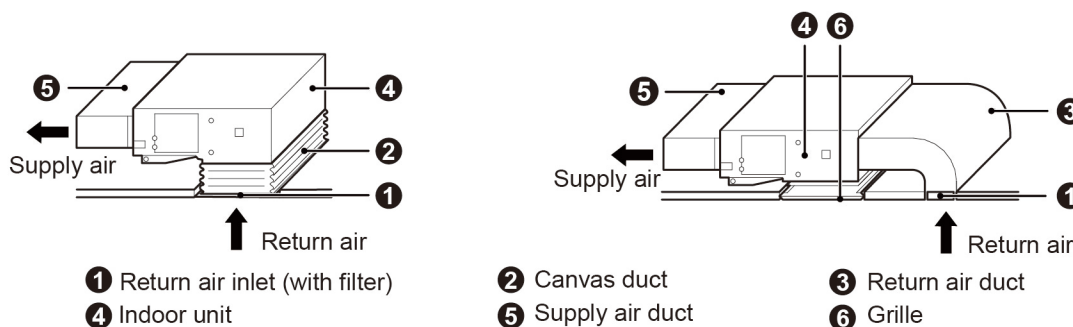

Fig.4.4.6

4.4.4 Installation of the Fresh Air Pipe

- (1) When the fresh air pipe is needed to be connected, cut the fresh air baffle as Fig 4.4.7. Plug up the gap of the fresh air baffle by sponge if the fresh air duct is not be used.
- (2) Install the round flange so that the fresh air duct can be connected as Fig 4.4.8.
- (3) Sealing and heat preservation should be done for both the air pipe and round flange pipe.
- (4) Fresh air should be treated via the air filter.

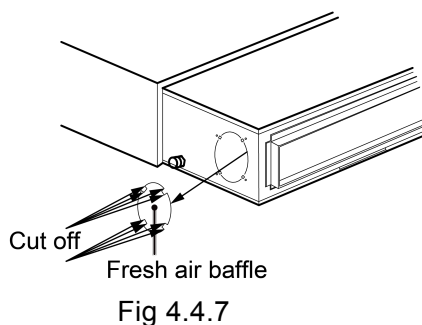

Fig 4.4.7

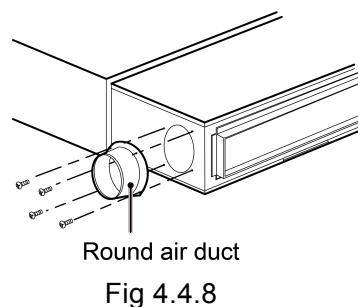

Fig 4.4.8

4.5 Installation of Wired Controller

Please refer to User Manual of Wired Controller for the installation details.

NOTICE

When installation is finished, the unit must be tested and debugged before operation. Please refer to Instruction Manual of ODU for auto addressing and debugging details.

5 Wiring Work

⚠ WARNING

Before obtaining access to terminals, all supply circuits must be disconnected.

NOTICE

- | |
|--------------------------------------------------------------------------------------------------------------------------------------------------|
| (1) Units must be earthed securely, or it may cause electric shock. |
| (2) Please carefully read the wiring diagram before carry out the wiring work, incorrect wiring could cause malfunction or even damage the unit. |
| (3) The unit should be powered by independent circuit and specific socket. |
| (4) The wiring should be in accordance with related regulations in order to ensure the units reliable running. |
| (5) Install circuit breaker for branch circuit according to related regulations and electrical standards. |
| (6) Keep cable away from refrigerant piping, compressor and fan motor. |

NOTICE

- (7) The communication wires should be separated from power cord and connection wire between indoor unit and outdoor unit.
- (8) Adjust the static pressure via wired controller according to site circumstance.

5.1 Connection of Wire and Patch Board Terminal

(1) The connection of wire (as shown in Fig.5.1.1)

- 1) Strip about 25mm (1inch) insulation of the wire end by stripping and cutting tool.
- 2) Remove the wiring screws on the terminal board.
- 3) Shape the tail of wire into ring by needle nose plier, and keep the gauge of ring in accordance with screw.
- 4) Use the screwdriver for tightening the terminal.

(2) The connection of stranded wire (as shown in Fig.5.1.2)

- 1) Strip about 10mm (3/8inch) insulation of the end of stranded wire by stripping and cutting tool.
- 2) Loosen the wiring screws on terminal board.
- 3) Insert the wire into the ring tongue terminal and tighten by crimping tool.
- 4) Use the screwdriver for tightening the terminal.

Unit: mm(inch)

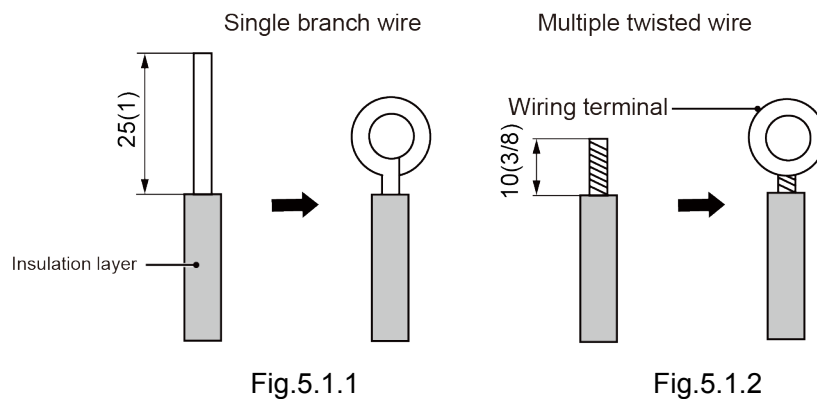

Fig.5.1.1

Fig.5.1.2

5.2 Power Cord Connection

NOTICE

Every unit should be equipped with a circuit breaker for short-circuit and overload protection. During operation, all indoor units connected to the same outdoor unit system must be kept energized status. Otherwise, the unit can't operate normally.

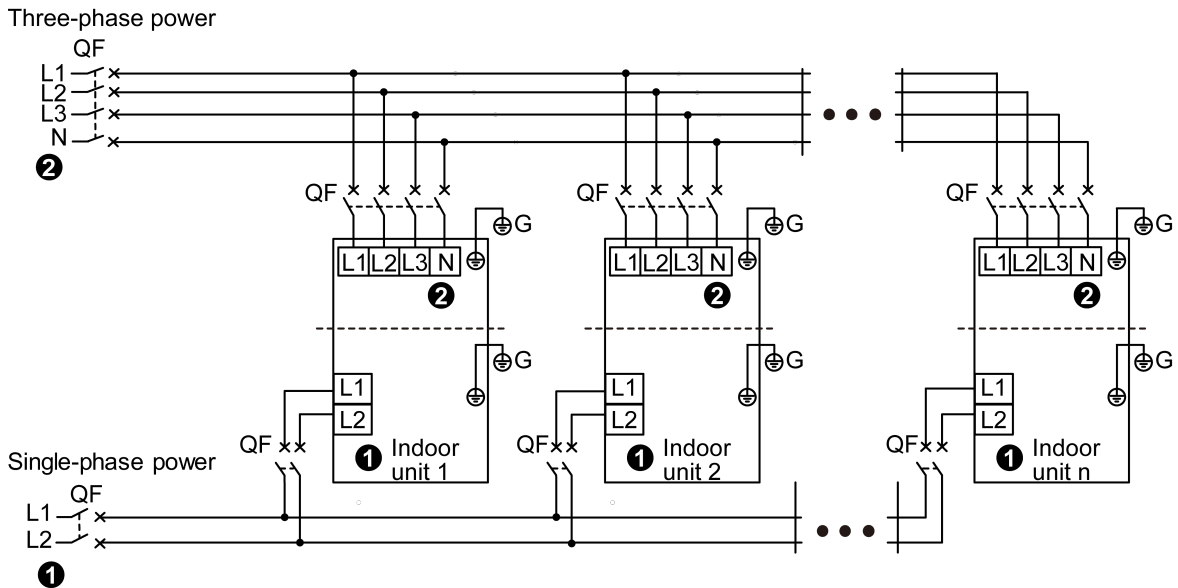

- NOTICE** (1) Connect wires for single-phase unit according to figure ① and connect wires for three-phase unit according to figure ②.
 (2) The maximum connection quantity "n" for indoor unit is decided by the capacity of outdoor unit. Please refer to the unit capacity of unit for details.

Fig.5.2.1

- (1) Detach the electric box lid.
- (2) Let the power cord pass through the wiring through-holes.
- (3) Connect wires according to Fig. 5.2.1.
- (4) Fix the power cord with wiring clamp.
- (5) The wire diameter of power cord can't be less than 18AWG.

5.3 Connection of Communication Wire between Indoor Unit and Outdoor Unit (or indoor unit)

- (1) Detach the electric box lid.
- (2) Let the Communication cable pass through the wiring through-holes.
- (3) Connect the communication wire to terminal D1 and D2 of indoor 4-bit wiring board, as shown in Fig.5.3.1.

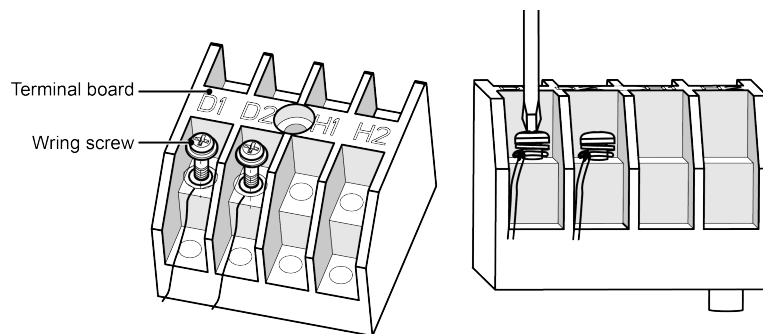
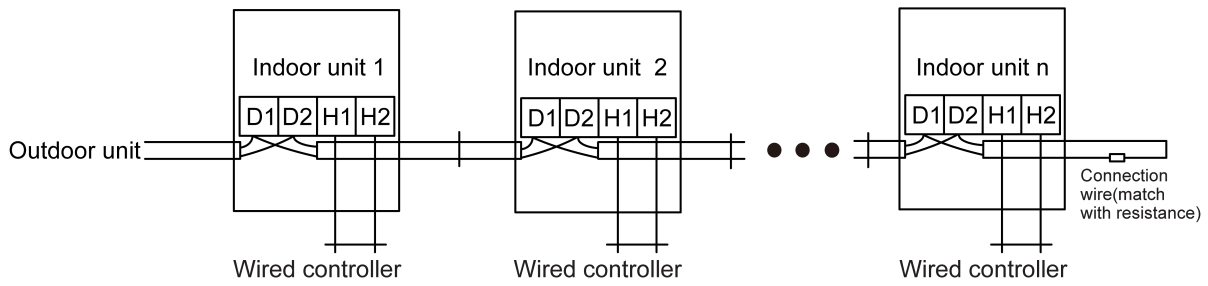

Fig.5.3.1



NOTICE Indoor unit quantity n is according to the outdoor unit capacity.

Fig.5.3.2

- (4) Fix the communication cable with clamp of electric box.
- (5) For more reliable communication, make sure connect the terminal resistor to the most downstream IDU of the communication bus (terminal D1 and D2), as shown in Fig.5.3.2, terminal resistor is provided with each ODU.

5.4 Connect Communication Wire of Wired Controller

- (1) Open electric box cover of indoor unit.
- (2) Let the communication wire go through the wiring through-holes.
- (3) Connect the communication wire to terminal H1 and H2 of indoor 4-bit wiring board.
- (4) Fix the communication wire with wire clip on the electric box.
- (5) Wiring instructions of remote receiving light board and wired controller:
See Fig. 5.4.1 for the installation of wired controller.

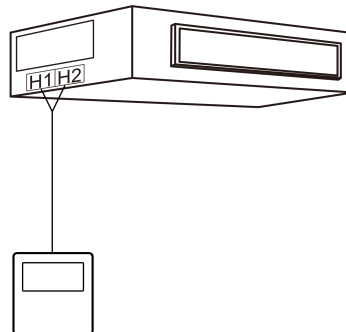

Fig.5.4.1

5.5 Illuminate for Connection of Wired Controller and Indoor Units Network

- (1) Communication wire of indoor unit and outdoor unit (or indoor unit) is connected to D1, D2.
- (2) Wired controller is connected to H1, H2.
- (3) One indoor unit can connect two wired controllers that must be set as master one and slave one.
- (4) One wired controller can control 16 indoor units in maximum at the same time (as shown in Fig.5.5.1).

NOTICE

- (1) The type of indoor units must be the same if they are controlled by the same wired controller.
- (2) When the indoor unit is controlled by two wired controllers, the addresses of the two wired controllers should be different through address setting. Address 1 is for main controller; Address 2 is for slave controller. Detailed setting please refer to the instruction manual of wired controller.

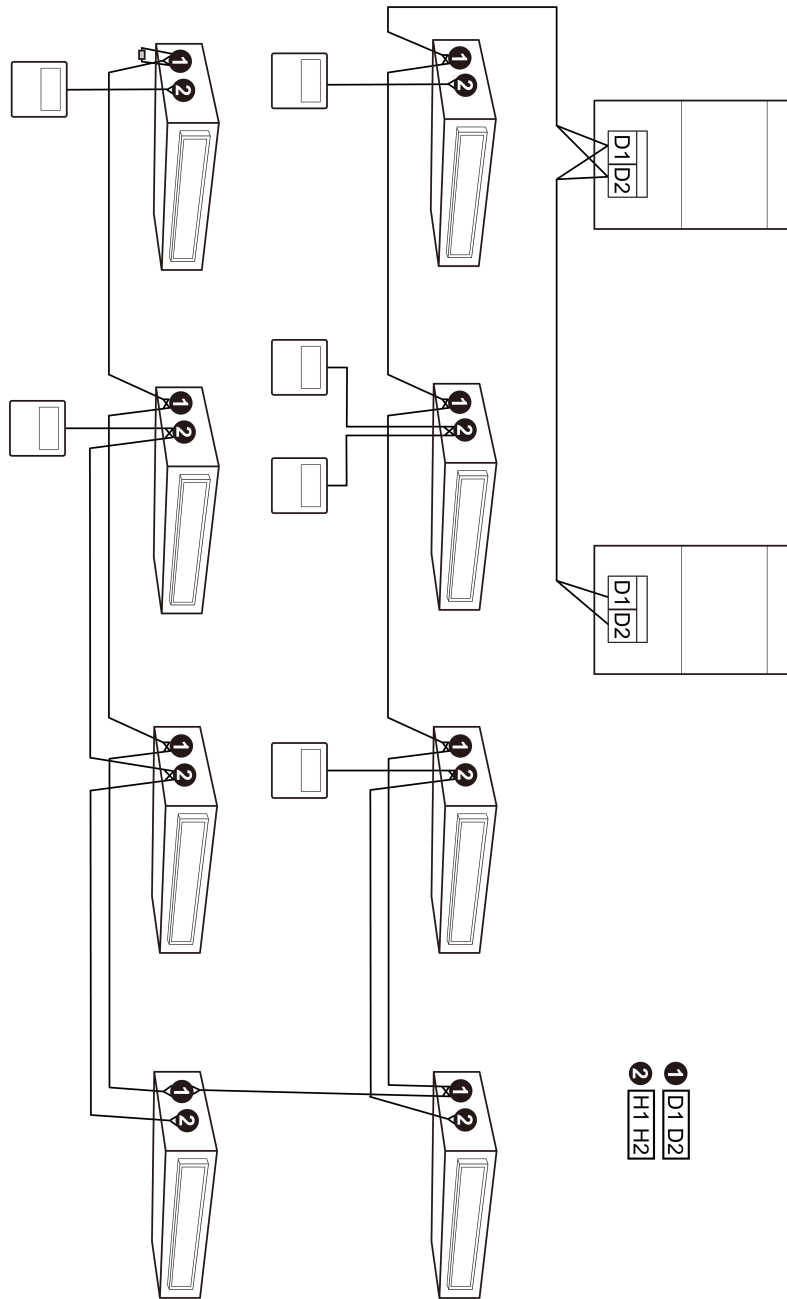

Fig.5.5.1

6 Setting of External Static Pressure

Working range for external static pressure of this series of duct type unit is 0 Pa~80 Pa. For corresponding external static pressure to the respective static pressure notch please see as below. The setting of static pressure for indoor fan can be done via wired controller. For specific setting method please see the Wired Controller Instruction Manual.

Applicable to: GMV-ND30~48PLS/C-T(U)					
Static pressure notch for indoor fan	3	4	5	6	7
External static pressure (Pa)	0	30	50	65	80

Note: The defaulted static pressure notch for all models at ex-factory is 5.

7 Routine Maintenance

NOTICE

- | |
|-------------------------------------------------------------------------------------------------------------------------------------|
| (1) Do not turn off the unit and cut off the main power supply when cleaning the air conditioner to avoid electric shock or injury. |
| (2) Stand at solid table when cleaning the unit. |
| (3) Do not clean the unit with hot water whose temperature is higher than 45°C (113°F) to prevent fade or deformation. |
| (4) Do not dry the filters by fire, or it may catch fire or become deformed. |
| (5) Clean the filter with a wet cloth dipped in neutral detergent. |
| (6) Please contact after-sales service staff if there is abnormal situation. |

7.1 Cleaning of Filter

- (1) Remove the filters from inlet of IDU. Use a vacuum cleaner to remove dust. If the filters are dirty, wash them with warm water and mild detergent, and dry the filters in the shade.
- (2) If the unit used in the environment with much dust, please clean it regularly (Usually once every two weeks).

7.2 Maintenance before the Seasonal Use

- (1) Check if the air inlet and air outlet of indoor and outdoor unit are blocked.
- (2) Check if securely grounded.
- (3) Check if all the power cord and communication cable are securely connected.
- (4) Check if any error code displayed after energized.

7.3 Maintenance after the Seasonal Use

- (1) Set the unit in fan mode for half a day in a sunny day to dry the inner part of unit;
- (2) When the unit won't be used for a long time, please cut off power supply for energy saving; the characters on the wired controller screen will disappear after cutting off the power supply.

8 The Table of Error Codes for Indoor Unit

Error Code	Content	Error Code	Content	Error Code	Content
L0	Indoor Unit Error	L9	Quantity Of Group Control Indoor Units Setting Error	d8	Water Temperature Error
L1	Indoor Fan Protection	LA	Indoor Units Incompatibility Error	d9	Jumper Cap Error
L2	E-heater Protection	LH	Low Air Quality Warning	dA	Indoor Unit Network Address Error
L3	Water Full Protection	LC	ODU-IDU Incompatibility Error	dH	Wired Controller PCB Error
L4	Wired Controller Power Supply Error	d1	Indoor Unit PCB Error	dC	Capacity DIP Switch Setting Error.
L5	Freeze protection	d3	Ambient Temperature Sensor Error	dL	Outlet Air Temperature Sensor Error
L7	No Master Indoor Unit Error	d4	Inlet Pipe Temperature Sensor Error	dE	Indoor Unit CO ₂ Sensor Error
L8	Power Insufficiency Protection	d6	Outlet Pipe Temperature Sensor Error	C0	Communication Error
L0	Indoor Unit Error	d7	Humidity Sensor Error	AJ	Filter Cleaning Reminder
o1	Low bus bar voltage of indoor unit	o2	High bus bar voltage of indoor unit	o3	IPM Module Protection of Indoor Unit

Error Code	Content	Error Code	Content	Error Code	Content
o4	Failure Startup of Indoor Unit	o5	Overcurrent Protection of Indoor Unit	o6	Current Detection Circuit Malfunction of Indoor Unit
o7	Desynchronizing Protection of Indoor Unit	o8	Communication Malfunction of Indoor Unit's Drive	o9	Communication Malfunction of Main Mater of Indoor Unit
oA	High temperature of Indoor Unit's Module	ob	Malfunction of Temperature Sensor of Indoor Unit's Module	oC	Charging Circuit Malfunction of Indoor Unit
o0	Other Drive Malfunction	db	Special Code: Field Debugging Code		

9 Troubleshooting

The air conditioner is not expected to be serviced by users. Incorrect repair may cause electric shock or fire, so please contact an authorized service center for professional service. The following checks prior to contact may save your time and money.

Phenomenon	Troubleshooting
The unit can't start.	<ul style="list-style-type: none"> ① Power supply is not connected. ② Circuit breaker tripping caused by leakage of electricity. ③ Input voltage is too low. ④ Defect of main PC-board.
The unit stops after running for a while.	<ul style="list-style-type: none"> ① The inlet or outlet of ODU or IDU are blocked by obstacle.
Poor cooling effect.	<ul style="list-style-type: none"> ① The filter is dirty. ② Too heavy heat load of room (e.g. too many people). ③ Door or windows is open. ④ Inlet and outlet of IDU are blocked. ⑤ Setting temperature is too high. ⑥ Refrigerant is insufficient (e.g. refrigerant leakage).
Poor heating effect.	<ul style="list-style-type: none"> ① The filter is dirty. ② Door or window is open. ③ Setting temperature is too low. ④ Refrigerant is insufficient (e.g. refrigerant leakage).
Indoor fan doesn't start up during heating.	<ul style="list-style-type: none"> ① At starting, the IDU fan could not operate till the heat exchange become hot, for preventing delivering the cool air. ② At defrosting, the IDU fan stopped due to system switch to cooling mode. For preventing delivering the cool air, and resume operating after defrosting.

NOTICE

If air conditioner still fails to work normally after checking and handling as described above, please stop using it immediately and contact local service center for assistance.

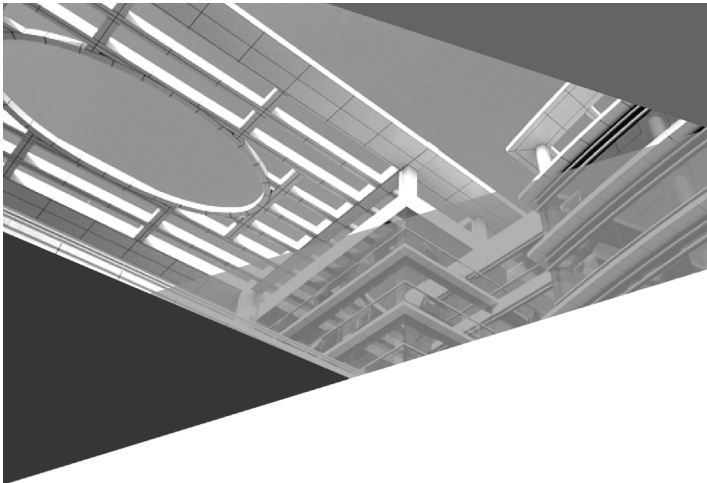

GREE ELECTRIC APPLIANCES, INC. OF ZHUHAI

Add: West Jinji Rd, Qianshan, Zhuhai, Guangdong, China, 519070

Tel: (+86-756) 8522218

Fax: (+86-756) 8669426

E-mail: global@cn.gree.com www.gree.com



600005062241