

460V Modular Heat Pump

Model:
GMV-72WM/B-U(U)



Specifications	Unit	Parameter
Model	—	GMV-72WM/B-U(U)
Performance		
Rated Cooling Capacity(*1)	kBtu/h	72
Rated Heating Capacity(*2)	kBtu/h	81
Power Input	Cooling(kw)	5.45
	Heating(kw)	5.8
Sound Pressure Level	dB(A)	60
Operating Temperature Range	Cooling(Outdoor)°C/°F	-5~52/23~125.6
	Heating(Outdoor)°C/°F	-20~24/-4~75
AHRI Ratings(Ducted/Non-Ducted)		
EER	(Btu/h)/W	11.1/11.3
IEER	(Btu/h)/W	20/23
COP	W/W	2.4~3.4/2.45~3.7
Electrical Data		
Power Supply	V/Ph/Hz	460/3/60
Maximum Overcurrent Protection (MOP)	A	20
Minimum Circuit Amps (MCA)	A	15
Fan		
Type x Quantity	—	Axial-flow×1
Air Flow Volume	CFM	6710
Fan Motor Running Current	A	1.4
Fan Motor Power Output	W	750
Max.External Static Pressure (ESP)	Pa/In.W.G	82/0.33
Compressor		
Compressor Type x Quantity	—	Inverter Scroll×1
Compressor Rated Load Amps (RLA)	A	10.1
Compressor Refrigerant Oil Type	—	FVC68D or FV68H
Compressor Refrigerant Oil Charge Volume	L/Gal	4.6/1.22
Refrigerant Piping		
Connection Pipe	Gas(mm/inch)	Φ19.05/Φ3/4
	Liquid(mm/inch)	Φ9.52/Φ3/8
Max. Equivalent Connection Pipe Length(ODU to IDU)	m/ft	165/541
Refrigerant Charge	kg/oz	6.5/229.3
Refrigerant	—	R410A
Dimension/Weight		
Dimensions (H×W×D)	mm/inch	1605×930×765 (63-3/16×36-5/8×30-1/8)
Net Weight	kg/lbs	228/503
Other		
Indoor Unit	Total Capacity(%)	50%~135% of outdoor unit
	Max Connectable Quantity	13
Certification	—	ETL/AHRI
Condenser Fin Color	—	Gold
Protection Devices	High Pressure	High pressure sensor, High pressure switch 601 psi (4.15 MPa)
	Inverter Circuit	Over-heat protection, Over-current protection
	Compressor	Discharge temp protection, Over-current protection

*1 Cooling | Indoor: 80°F(26.7°C)DB / 67°F(19°C)WB; Outdoor: 95°F(35°C)DB

*2 Heating | Indoor: 70°F(21.1°C)DB / Outdoor: 47°F(8.3°C)DB / 43°F(6°C)WB

Job Name:		Date:	
System Reference No.:			
Engineer Signature:			

Outline and Physical Dimensions of GMV-72WM/B-U(U).

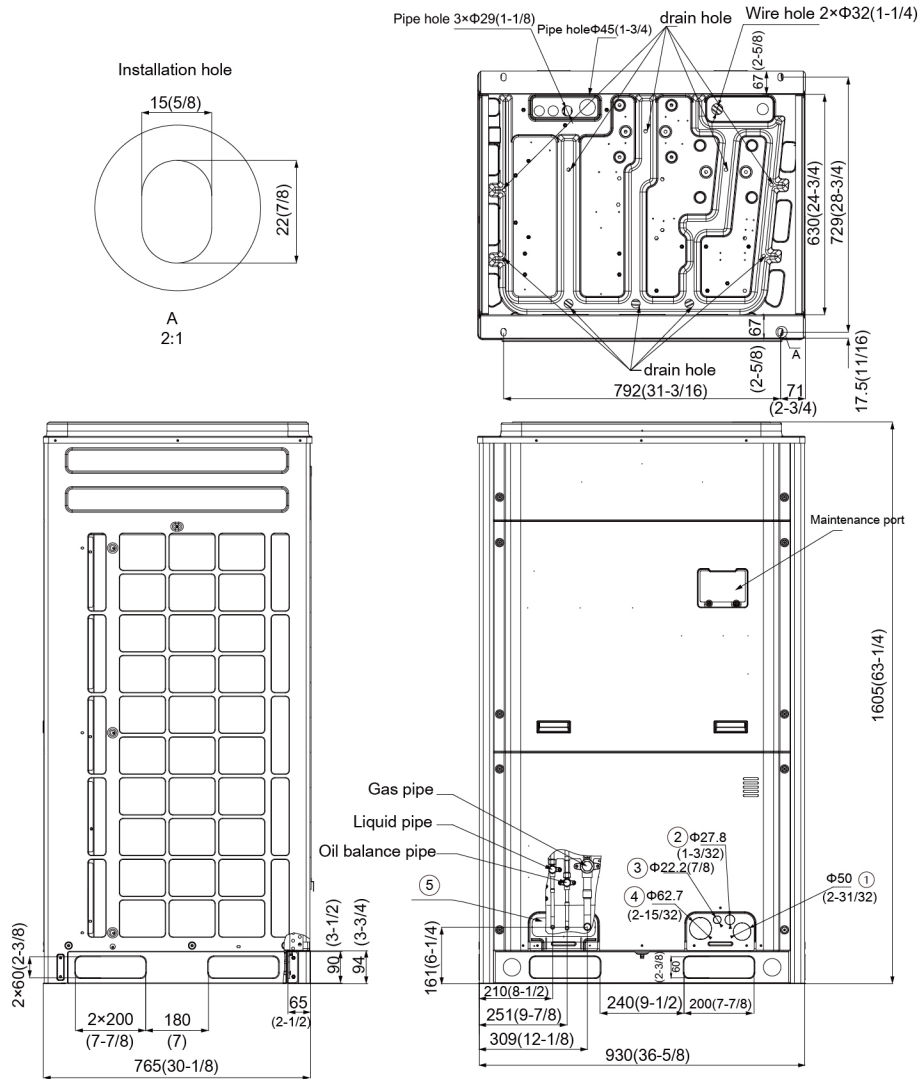

No.	Usage	Size mm(in.)
①	Wire	Φ50(2-31/32)
②		Φ27.8(1-3/32)
③		Φ22.2(7/8)
④		Φ62.7(2-15/32)
⑤	Pipe	180×53(7×2)

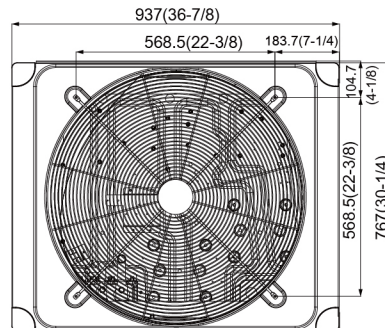

Unit:mm(in.)