

ULTRA HEAT GMV MULTI VRF UNIT

— Heat Pump Series

CAPACITY RANGE: 21.1~28.1KW(72~96kBtu/h)

OPERATING RANGE:

COOLING: -10~52 °C (14~125.6°F)

HEATING: -30~24 °C (-22~75.2°F)



R410A



CONTENTS

CONTENTS.....	1
1 OUTLINE OF MULTI VRF.....	3
1.1 Energy Efficient.....	3
1.2 Comfortable Mute.....	3
1.3 Advanced Technology to Ensure Stability and Reliability.....	4
1.4 Humanized Engineering Operation.....	4
1.5 Intelligent Management.....	4
1.6 Wide Operation Range.....	5
1.7 High Static Pressure Design of ODU to Realize More Flexible Selection.....	5
2 SUMMARY OF SYSTEM EQUIPMENTS.....	6
2.1 Outdoor Unit.....	6
2.2 Combination Mode.....	8
2.3 Electrical Specifications.....	8
2.4 Indoor Unit.....	9
2.5 Controller.....	14
3 INTERNAL PIPING DESIGN OF THE UNITS.....	15
3.1 Piping Diagram of GMV-V72W/A-F(U) and GMV-V96W/A-F(U).....	15
3.2 Names and main functions of components.....	15
4 EQUIPMENT SELECTION PROCEDURE.....	18
4.1 Selection Flow Chart.....	18
4.2 Combination Conditions for Indoor Unit and Outdoor Unit.....	18
4.3 Cooling/Heating Capacity Characteristics.....	19
4.3.1 Cooling capacity calculation method.....	19
4.3.2 Heating capacity calculation method.....	19
4.3.3 Capacity calculation for each indoor unit.....	20
4.3.4 Operating temperature range.....	20
4.4 Example of Equipment Selection.....	20
4.4.1 Overview of building model.....	20
4.4.2 Selection criteria for each apartment.....	21
4.4.3 Procedure and result of equipment selection.....	21
5 UNIT GRAVITY CENTER DIAGRAMS.....	23
6 UNIT INSTALLATION SPACE REQUIREMENTS.....	24
6.1 Selection of Outdoor Unit Installation Site.....	24
6.2 External Dimensions and Mounting Hole Dimensions of the Outdoor Unit.....	24
6.3 External Unit Installation Space Requirements.....	24
7 MODEL SELECTION FOR UNIT PIPING.....	29
7.1 Schematic Diagram of Piping Connection.....	29
7.2 Allowable Pipe Length and Drop Height Among Indoor and Outdoor Units.....	29
7.3 Connection pipe among outdoor modules.....	31
7.4 Size Requirement for Branch Pipe and Piping (Main Pipe).....	32

7.4.1 Connection sketch map of single-module system.....	32
7.4.2 Select appropriate pipe between outdoor unit and the first indoor branch (“L”) as per the pipe size of outdoor unit.....	33
7.5 Attention before operation.....	35
8 REQUIREMENTS FOR COMMUNICATION MODE.....	37
8.1 Connection Mode of Connection Line Terminals.....	37
8.2 Communication Cable Material and Wring Mode.....	38
8.2.1 Communication material.....	38
8.2.2 Communication access mode.....	39
8.3 Connection Method and Procedure of Communication Cable.....	40
8.3.1 Communication connection between the indoor unit and outdoor unit.....	40
8.3.2 Communication connection mode between the indoor unit and wired controller.....	42
8.3.3 Connection mode between the air duct-type indoor unit and receiving LED panel.....	44
9 ELECTRICAL CONNECTION.....	45
9.1 External Connection Interfaces.....	45
9.2 External Connection.....	45
10 CALCULATION METHOD OF REFRIGERANT ADDED FOR ENGINEERING PIPING.....	46
11 OPTIONAL COMPONENTS.....	47

1 OUTLINE OF MULTI VRF

Ultra Heat GMV Multi VRF heat pump Units: The basic models of the whole series are 6ton, 8ton: GMV-V72W/A-F(U) and GMV-V96W/A-F(U); and the combination model are 12ton, 14ton, 16 ton, GMV-V144WM/A-F(U), GMV-V168WM/A-F(U), GMV-V192WM/A-F(U).



6ton~8ton



12ton, 14ton, 16ton

1.1 Energy Efficient

The products benefit from the advanced DC inverter technology, optimized air conditioner system design, and accurate intelligent control technology.

➤ Multi-cylinder jet type compression technology

Ultra Heat GMV units adopt multi-cylinder enthalpy-adding compressor, which is first developed by GREE. With stronger driving force and variable discharge ratio, capacity is increased by 5%~10% under general working condition, and 100% under high/low temperature condition. EER is improved by 20%. It is more efficient, with less noise and longer service life.

➤ Two-stage compression and high frequency weak magnetism

Two-stage compression and HF weak magnetism technology is adopted. Compressor can work at higher frequency, with stronger output capacity and better heating performance. Extreme performance provides up to 100% heating output at -4°F and stable operation under -22°F .

➤ High efficiency enthalpy-adding technology

Precisely adjust flow volume and intermediate air make-up volume of main circulation system to make sure compressor and evaporator running at the best efficiency and realize energy saving and stable operation.

➤ Boost three phases PFC

Traditional AC/DC exchange doesn't control current, so current input has much harmonic hurting electric power network. Generally traditional electric power network power factor is 0.7~0.8, while boost three phases PFC adopts active devices to rectifier and power factor can advance to 0.99. Also boost three phases PFC can export lower voltage more efficiently, which is better applied in big power network.

1.2 Comfortable Mute

Ultra Heat GMV air conditioning units fully consider the comfort requirement of people, and the humanized technology further perfects the degree of comfort. The wider operation range of the units ensures normal

operation in sub-zero weather or hot weather. The better mute effect creates a quiet environment for work and life.

➤ **ODU mute mode**

When the unit is installed at a place with the requirement for a lower noise level, it should operate in the mute mode in the daytime and at night. In this case, three forced mute setting modes can be selected to ensure that the unit operates at the low noise mode all the time.

➤ **IDU mute mode**

The indoor unit also adopts the DC inverter motor to implement stepless speed regulation and greatly reduce the noise level. Moreover, the wired controller can be used to set the automatic mute mode of indoor unit and enable the automatic mute function according to the indoor temperature and movements of persons.

1.3 Advanced Technology to Ensure Stability and Reliability

Ultra Heat GMV units have earned a reputation in the field due to the high technical content. Thanks to research and experiments for more than one decade, all the technologies of GMV have become more matured. Gree Ultra Heat GMV has been upgraded in an all-round way, including electric elements, machine elements, control technology and communication technology. Continuous revolution in technologies must bring more reliable and efficient service to users.

➤ **Oil return control of new generation**

Ultra Heat GMV units adopt intelligent oil return technology actively, which controls the compressor's oil-balance pipe to realize oil return of the system and oil discharge in case that system will store overfull oil for impairing heat exchange. All compressors oil level is around by oil-balance pipe, and system's overfull oil can be returned to the compressor by oil-balance pipe in case of reducing compressor life for lack of oil. Also compressor's overfull oil can be discharged by oil-balance pipe in case of oil strike fault for higher oil level, thus increasing the service life of the compressor substantially.

➤ **Unique comfortability control**

The outdoor unit is regulated using dual electronic expansion valves within the regulation range of 960 stages to accurately realize the flow control between the indoor unit module and outdoor unit module, so the system operates more stably.

➤ **Heating can start quickly.**

1.4 Humanized Engineering Operation

➤ **The unit is characterized by automatic address allocation and non-polarity communication.**

➤ **The unit can perform automatic debugging and fault detection. Ultra Heat GMV has five automatic debugging functions.**

1) Automatically allocating indoor and outdoor unit addresses; 2) Automatically checking the quantities of indoor and outdoor units; 3) Automatically detecting internal faults of units; 4) Automatically starting debugging; 5) Judging pipeline exceptions in real time.

1.5 Intelligent Management

➤ **The units are designed in the dual-energy saving operation modes.**

Along with penetration of energy conservation and emission reduction and increasingly strict requirements for power utilization in cities raised by the state, a lot of cities will issue corresponding power rationing measures in the peak of power consumption, especially in summer. Ultra Heat GMV conditioning units unit provides two energy saving modes for users to select as needed and meets the requirements for off-peak power consumption and power brownout in cities.

Energy saving mode 1: When the unit is set to the automatic energy saving mode during operation, the system automatically adjusts and controls the target parameter according to the operating status, and greatly reduces power consumption of the whole system.

Energy saving mode 2: When the unit is set to the forced energy saving mode during operation, the system forcedly limits power output of the system.

- **The unit is provided with the energy consumption analysis function and corresponding solution.**
- **The unit supports the emergency shutdown function.**

With remote monitoring, the outdoor unit can directly intervene in the fire alarm linkage signal, and the whole system can stop immediately in case of an emergency to avoid more risk losses.

- **The unit has the management function by area.**

1.6 Wide Operation Range

Operating temperature range: -10°C to 52°C ($14\sim 125.6^{\circ}\text{F}$) for cooling; -30°C to 24°C ($-22\sim 75.2^{\circ}\text{F}$) for heating;
Operating range of power supply: 3~, 208/230V, 60Hz.

1.7 High Static Pressure Design of ODU to Realize More Flexible Selection

The unit is provided with four levels of static pressures: 0 Pa (0In.W.G), 30 Pa (0.12In.W.G), 50 Pa (0.20In.W.G), and 82 Pa (0.328In.W.G). The corresponding static pressure can be selected for the outdoor unit according to the building form, and the maximum static pressure is 82 Pa (0.328In.W.G). The unit especially applies to the scenario where the outdoor unit needs to be placed indoors.

2 SUMMARY OF SYSTEM EQUIPMENTS







2.1 Outdoor Unit

Outdoor Units_Heat Pump		Ton	6	8	12	14	16
Model		-	GMV-V72W/A -F(U)	GMV-V96W/A -F(U)	GMV-V144WM/ A-F(U)	GMV-V168WM/ A-F(U)	GMV-V192WM/ A-F(U)
Combination Model		-	/	/	GMV-V72W/A-F(U)+ GMV-V72W/A-F(U)	GMV-V72W/A-F(U)+ GMV-V96W/A-F(U)	GMV-V96W/A-F(U)+ GMV-V96W/A-F(U)
Perform ance	Nominal Cooling Capacity	KBtu/h	72	96	144	168	192
		kW	21.1	28.1	42.2	49.2	56.3
	Rated Cooling Capacity①	KBtu/h	69	92	138	160	184
		kW	20.2	27.0	40.45	46.89	53.9
	Nominal Heating Capacity	KBtu/h	81	108	162	189	216
		kW	23.7	31.6	47.5	55.4	63.3
	Rated Heating Capacity	KBtu/h	77	103	154	180	200
		kW	22.6	30.2	45.13	52.76	58.6
	Cooling Power Input	kW	6.16	8.36	12.58	14.79	17.36
	Heating Power Input	kW	6.64	8.88	13.67	16.25	18.03
Sound Pressure Level	dB(A)	60	60	/	/	/	
Power Supply	-	208/230V 3~ 60HZ					
Compres sor	Type	-	Inverter Rotary	Inverter Rotary	Inverter Rotary	Inverter Rotary	Inverter Rotary
	Number	N	2	2	2+2	2+2	2+2
	Motor Output	kW	5.83×2	5.83×2	5.83×2 +5.83× 2	5.83×2 +5.83× 2	5.83×2 +5.83× 2

	Starting Method	-	Inverter	Inverter	Inverter	Inverter	Inverter
	Operating Range	-	10%~100%	10%~100%	10%~100%	10%~100%	10%~100%
	Refrigeration Oil Brand	-	FV50S	FV50S	FV50S	FV50S	FV50S
	Oil Charge	L	1.35×2	1.35×2	1.35×2+1.35×2	1.35×2+1.35×2	1.35×2+1.35×2
Fan	Type×Quantity	-	Propeller×2	Propeller×2	Propeller×2	Propeller×2	Propeller×2
	Motor Output	W	750+750	750+750	750×2+750×2	750×2+750×2	750×2+750×2
	Starting Method	-	Inverter	Inverter	Inverter	Inverter	Inverter
	Air Flow Rate	m3/h	14000	14000	14000+14000	14000+14000	14000+14000
		cfm	8239	8239	8239+8239	8239+8239	8239+8239
	Max. External Static Pressure	Pa	82	82	82	82	82
in.W.G		0.328	0.328	0.328	0.328	0.328	
Ambient Temperature Range	Cooling	°C	-10~52	-10~52	-10~52	-10~52	-10~52
		°F	14~125.6	14~125.6	14~125.6	14~125.6	14~125.6
	Heating	°C	-30~24	-30~24	-30~24	-30~24	-30~24
		°F	-22~75.2	-22~75.2	-22~75.2	-22~75.2	-22~75.2
Refrigerant	Type	-	R410A	R410A	R410A	R410A	R410A
	Charge Volume	kg	11	11	11+11	11+11	11+11
		lbs.	24.3	24.3	24.3+24.3	24.3+24.3	24.3+24.3
	Control	-	EEV	EEV	EEV	EEV	EEV
Pipe Connection	Gas Pipe Size	mm	28.6	28.6	34.9	34.9	34.9
		in.	1-1/8	1-1/8	1-3/8	1-3/8	1-3/8
	Liquid Pipe Size	mm	12.7	12.7	15.9	15.9	15.9
		in.	1/2	1/2	5/8	5/8	5/8
Dimensions (width×depth×height)	External Dimension	mm	1340×765×1605	1340×765×1605	1340×765×1605+1340×765×1605	1340×765×1605+1340×765×1605	1340×765×1605+1340×765×1605
		in.	52-3/4×30-1/8×63-1/5	52-3/4×30-1/8×63-1/5	52-3/4×30-1/8×63-1/5+52-3/4×30-1/8×63-1/5	52-3/4×30-1/8×63-1/5+52-3/4×30-1/8×63-1/5	52-3/4×30-1/8×63-1/5+52-3/4×30-1/8×63-1/5

					× 63-1/5	× 63-1/5	× 63-1/5
Packaging Dimension	mm	1420×840×	1420×840×	1420×840×	1775+	1775+	1775+
		1775	1775	1775	1420×840×	1420×840×	1420×840×
Packaging Dimension	in.	56×33×	56×33×	56×33×	69-7/8+	69-7/8+	69-7/8+
		69-7/8	69-7/8	69-7/8	56×33×69-7/8	56×33×69-7/8	56×33×69-7/8
Weight	Net Weight	kg	375.0	375.0	750.0	750.0	750.0
		lbs.	826.9	826.9	1653.8	1653.8	1653.8
	Gross Weight	kg	391.0	391.0	782.0	782.0	782.0
		lbs.	862.2	862.2	1724.3	1724.3	1724.3
Maximum Quantity of Connected Indoor Unit		unit	12	17	24	29	34
Protection Devices	High Pressure Protection	-	High pressure sensor, high pressure switch				
	Compressor/Fan	-	Over-current protection, over-heat protection				
	Inverter	-	Over-current protection				
Remark	<p>1. Rating conditions: Cooling: Indoor 26.7°C (80.1°F)DB/19.4°C (66.9°F)WB, Outdoor 35°C (95°F)DB/23.9°C (75°F)WB Heating: Indoor 21.1°C (70°F)DB/15°C (59°F)WB, Outdoor 8.3°C (46.9°F)DB/6.1°C (43°F)WB</p> <p>2. It refers to the operation power of compressor under ARI test conditions (condensing temp.130°F, evaporating temp.45°F, return gas temp.65°F, liquid temp.115°F) at 60HZ.</p> <p>3. Oil charge includes the total oil amount of outdoor units, residual oil amount of compressor and oil separate tank. When replacing the compressor or oil separate tank, only the corresponding required oil amount shall be charged.</p>						

2.2 Combination Mode

Single Model	GMV-V72W/A-F(U)	GMV-V96W/A-F(U)
GMV-V72W/A-F(U)		
GMV-V96W/A-F(U)		
GMV-V144WM/A-F(U)		
GMV-V168WM/A-F(U)		
GMV-V192WM/A-F(U)		

2.3 Electrical Specifications

ODU Model	Power Supply	Fuse Capacity	Minimum Circuit Ampacity	Maximum Overcurrent Protection
	V/Ph/Hz	A	A	A
GMV-V72W/A-F(U)	208/230V 3Ph 60Hz	50	40	50
GMV-V96W/A-F(U)	208/230V 3Ph 60Hz	60	45	60
GMV-V144WM/A-F(U)	208/230V 3Ph 60Hz	50+50	40+40	50+50
GMV-V168WM/A-F(U)	208/230V 3Ph 60Hz	50+60	40+45	50+60
GMV-V192WM/A-F(U)	208/230V 3Ph 60Hz	60+60	45+45	60+60

2.4 Indoor Unit

Type	Appearance	Model	Cooling Capacity		Heating Capacity	
			kW	kBtu/h	kW	kBtu/h
Super High Duct Type		GMV-ND07PHS/B-T(U)	2.2	7.5	2.5	8.5
		GMV-ND09PHS/B-T(U)	2.8	9.5	3.1	10.5
		GMV-ND12PHS/B-T(U)	3.5	12	4.0	13.5
		GMV-ND15PHS/B-T(U)	4.4	15	5	17
		GMV-ND18PHS/B-T(U)	5.3	18	5.9	20
		GMV-ND22PHS/B-T(U)	6.4	22	7.0	24
		GMV-ND24PHS/B-T(U)	7.0	24	7.9	27
		GMV-ND30PHS/B-T(U)	8.8	30	10.0	34
		GMV-ND36PHS/B-T(U)	10.6	36	11.7	40
		GMV-ND42PHS/B-T(U)	12.3	42	13.8	47
		GMV-ND48PHS/B-T(U)	14.1	48	15.8	54
GMV-ND54PHS/B-T(U)	15.8	54	17.6	60		

Type	Appearance	Model	Cooling Capacity		Heating Capacity	
			kW	kBtu/h	kW	kBtu/h
Floor Ceiling		GMV-ND09ZD/A-T(U)	2.8	9.5	3.1	10.5
		GMV-ND12ZD/A-T(U)	3.5	12	4.0	13.5
		GMV-ND18ZD/A-T(U)	5.3	18	5.9	20
		GMV-ND24ZD/A-T(U)	7.0	24	7.9	27
		GMV-ND30ZD/A-T(U)	8.8	30	9.7	33
		GMV-ND36ZD/A-T(U)	10.6	36	11.7	40
		GMV-ND42ZD/A-T(U)	12.3	42	13.8	47
		GMV-ND48ZD/A-T(U)	14.1	48	15.8	54

Type	Appearance	Model	Cooling Capacity		Heating Capacity	
			kW	kBtu/h	kW	kBtu/h
Duct Type with High ESP		GMV-ND18PHS/A-T(U)	5.3	18	5.9	20
		GMV-ND24PHS/A-T(U)	7.0	24	7.9	27
		GMV-ND30PHS/A-T(U)	8.8	30	10	34
		GMV-ND36PHS/A-T(U)	10.6	36	11.7	40
		GMV-ND42PHS/A-T(U)	12.3	42	13.8	47
		GMV-ND48PHS/A-T(U)	14.1	48	15.8	54

Type	Appearance	Model	Cooling Capacity		Heating Capacity	
			kW	kBtu/h	kW	kBtu/h
Console		GMV-ND07C/A-T(U)	2.2	7.5	2.5	8.5
		GMV-ND09C/A-T(U)	2.8	9.5	3.2	11
		GMV-ND12C/A-T(U)	3.5	12	4.0	13.5
		GMV-ND18C/A-T(U)	5.3	18	5.9	20

Type	Appearance	Model	Cooling Capacity		Heating Capacity	
			kW	kBtu/h	kW	kBtu/h
Large Duct		GMV-ND72PH/A-T(U)	20.2	69	22.6	77
		GMV-ND96PH/A-T(U)	27	92	30.2	103
		GMV-ND72PH/B-T(U)	21.1	72	23.7	81
		GMV-ND96PH/B-T(U)	28.1	96	31.7	108

Type	Appearance	Model	Cooling Capacity		Heating Capacity	
			kW	kBtu/h	kW	kBtu/h
2 Way Cassette		GMV-ND09TS/A-T(U)	2.8	9.5	3.1	10.5
		GMV-ND12TS/A-T(U)	3.5	12	4.0	13.5
		GMV-ND15TS/A-T(U)	4.4	15	5.0	17
		GMV-ND18TS/A-T(U)	5.3	18	5.9	20
		GMV-ND24TS/A-T(U)	7.0	24	7.9	27

Type	Appearance	Model	Cooling Capacity		Heating Capacity	
			kW	kBtu/h	kW	kBtu/h
Slim Duct Type with Low ESP (Left type)		GMV-ND07PLS/A-T(U)	2.2	7.5	2.5	8.5
		GMV-ND09PLS/A-T(U)	2.8	9.5	3.1	10.5
		GMV-ND12PLS/A-T(U)	3.5	12	4.0	13.5
		GMV-ND14PLS/A-T(U)	4.0	14	4.5	15
		GMV-ND18PLS/A-T(U)	5.3	18	5.9	20
		GMV-ND22PLS/A-T(U)	7.0	24	7.9	27

Type	Appearance	Model	Cooling Capacity		Heating Capacity	
			kW	kBtu/h	kW	kBtu/h
Slim Duct Type with Low ESP (Right type)		GMV-ND07PLS/B-T(U)	2.2	7.5	2.5	8.5
		GMV-ND09PLS/B-T(U)	2.8	9.5	3.2	11
		GMV-ND12PLS/B-T(U)	3.5	12	4.0	13.5
		GMV-ND14PLS/B-T(U)	4.0	15	4.5	17
		GMV-ND18PLS/B-T(U)	5.3	18	5.9	20
		GMV-ND24PLS/B-T(U)	7.0	24	7.9	27

Type	Appearance	Model	Cooling Capacity		Heating Capacity	
			kW	kBtu/h	kW	kBtu/h
Compact 4-way Cassette		GMV-ND07T/B-T(U)	2.2	7.5	2.5	8.5
		GMV-ND09T/B-T(U)	2.8	9.5	3.1	10.5
		GMV-ND12T/B-T(U)	3.5	12	4.0	13.5
		GMV-ND15T/B-T(U)	4.4	15	5.0	17
		GMV-ND18T/B-T(U)	5.3	18	5.9	20

Type	Appearance	Model	Cooling Capacity		Heating Capacity	
			kW	kBtu/h	kW	kBtu/h
Wall Mounted Type		GMV-N07G/A3A-D(U)	2.2	7.5	2.5	8.5
		GMV-N09G/A3A-D(U)	2.8	9.5	3.2	11
		GMV-N12G/A3A-D(U)	3.5	12	4.0	13.5
		GMV-N18G/A3A-D(U)	5.3	18	5.9	20
		GMV-N24G/A3A-D(U)	7.0	24	7.5	25.5

Type	Appearance	Model	Cooling Capacity		Heating Capacity	
			kW	kBtu/h	kW	kBtu/h
4 Way Cassette		GMV-ND07T/A-T(U)	2.2	7.5	2.5	8.5
		GMV-ND09T/A-T(U)	2.8	9.5	3.1	10.5
		GMV-ND12T/A-T(U)	3.5	12	4.0	13.5
		GMV-ND15T/A-T(U)	4.4	15	5.0	17
		GMV-ND18T/A-T(U)	5.3	18	5.9	20
		GMV-ND24T/A-T(U)	7.0	24	7.9	27
		GMV-ND30T/A-T(U)	8.8	30	10	34
		GMV-ND36T/A-T(U)	10.6	36	11.7	40
		GMV-ND42T/A-T(U)	12.3	42	13.8	47
		GMV-ND48T/A-T(U)	14.1	48	15.8	54

Type	Appearance	Model	Cooling Capacity		Heating Capacity	
			kW	kBtu/h	kW	kBtu/h
1 Way Cassette		GMV-ND07TD/A-T(U)	2.2	7.5	2.5	8.5
		GMV-ND09TD/A-T(U)	2.8	9.5	3.1	10.5
		GMV-ND12TD/A-T(U)	3.5	12	4.0	13.5

Type	Appearance	Model	Cooling Capacity		Heating Capacity	
			kW	kBtu/h	kW	kBtu/h
100% Fresh Air Handler Unit		GMV-NDX42P/A-T(U)	12.3	42	8.5	29
		GMV-NDX48P/A-T(U)	14.1	48	10	34
		GMV-NDX54P/A-T(U)	15.8	54	13.2	45
		GMV-NDX72P/A-T(U)	21.1	72	16.1	55
		GMV-NDX96P/A-T(U)	28.1	96	19.9	68

Type	Appearance	Model	Cooling Capacity		Heating Capacity	
			kW	kBtu/h	kW	kBtu/h
Air Handler		GMV-ND09A/A-T(U)	2.8	9.5	3.1	10.5
		GMV-ND12A/A-T(U)	3.5	12	4.0	13.5
		GMV-ND18A/A-T(U)	5.3	18	5.9	20
		GMV-ND24A/A-T(U)	7.0	24	7.9	27
		GMV-ND30A/A-T(U)	8.8	30	10	34
		GMV-ND36A/A-T(U)	10.6	36	11.7	40
		GMV-ND42A/A-T(U)	12.3	42	13.8	47
		GMV-ND48A/A-T(U)	14.1	48	15.8	54
		GMV-ND54A/A-T(U)	15.8	54	17.6	60

Type	Appearance	Model	Cooling Capacity		Heating Capacity	
			kW	kBtu/h	kW	kBtu/h
Wall Mounted Type Indoor Unit (Lomo)		GMV-ND06G/B4B-T(U)	1.8	6	1.8	6
		GMV-ND07G/B4B-T(U)	2.2	7.5	2.5	8.5
		GMV-ND09G/B4B-T(U)	2.8	9.5	3.2	11
		GMV-ND12G/B4B-T(U)	3.5	12	4	13.5
		GMV-ND14G/B4B-T(U)	4.4	15	5	17
		GMV-ND18G/B4B-T(U)	5.3	18	5.9	20
		GMV-ND24G/B4B-T(U)	7	24	7.5	25.5
		GMV-ND30G/B4B-T(U)	8.8	30	10	34
		GMV-ND36G/B4B-T(U)	9.5	32.5	10.5	36

Rated Conditions

Cooling: Indoor 26.7°C (80.1°F)DB/19.4°C (66.9°F)WB, Outdoor 35°C (95°F)DB/23.9°C (75°F)WB



Heating: Indoor 21.1°C (70°F)DB/15°C (59°F)WB, Outdoor 8.3°C (46.9°F)DB/6.1°C (43°F)WB



Caution:

Ultra Heat GMV multi VRF unit selection must abide by technical sales manual. It is not recommended to adopt the combination mode not specified by this manual.

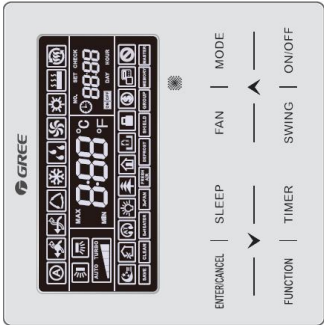
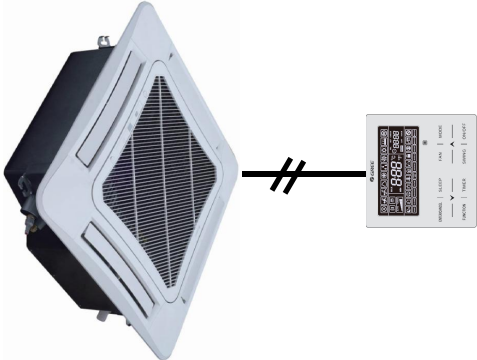
2.5 Controller

Name	Model Name	Appearance	Application	Function
Wired Controller	XK46 XK79			<ul style="list-style-type: none"> ◇ Start/Stop ◇ Mode changing ◇ Temperature setting ◇ Air flow changing ◇ Time setting ◇ Self-diagnosing function ◇ Display codes of trouble ◇ Control by 2 controller separately ◇ One indoor unit can be separately operated by wired controller and remote controller.
Remote Controller	YV111 YAP1F			<ul style="list-style-type: none"> ◇ Start/Stop ◇ Mode changing ◇ Temperature setting ◇ Air flow changing ◇ Time setting

3 INTERNAL PIPING DESIGN OF THE UNITS

3.1 Piping Diagram of GMV-V72W/A-F(U) and GMV-V96W/A-F(U)

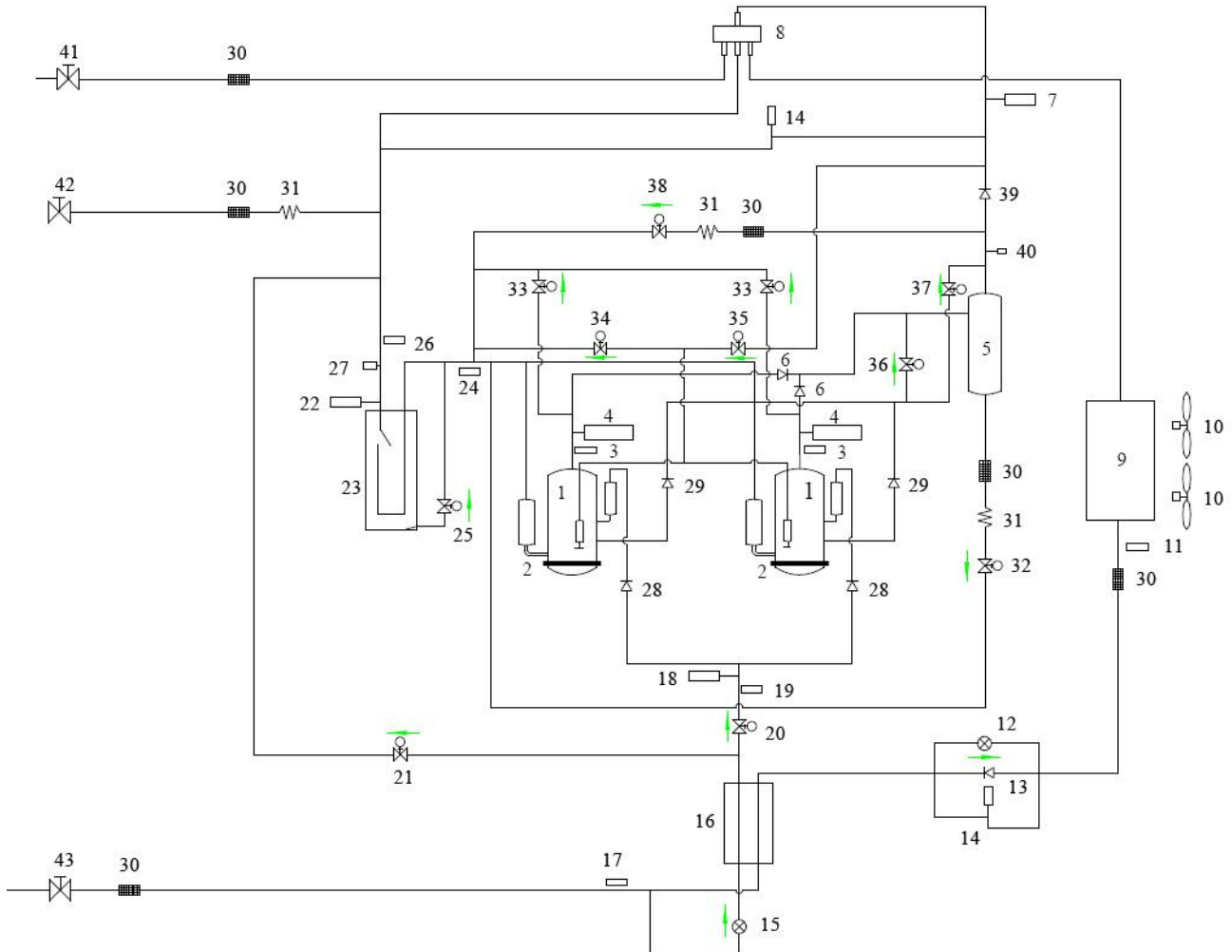

3.2 Names and main functions of components

No.	Name	Main Function
1	Compressor	Adjusts its own rotational speed based on the actual requirement of the system to implement capacity control.
2	Compressor heat tape	Maintains a proper oil temperature in the compressor when the compressor is in standby status, ensuring the reliability during compressor startup.
3	Exhaust pipe temperature sensor of compressor	Detects a compressor's exhaust gas temperature for compressor control and protection.
4	High-pressure circuit breaker	Protects a compressor by sending feedback signal to stop the system when the compressor's discharge pressure exceeds the operating value of high-pressure circuit breaker.

5	Oil extractor	Separates the gas and oil in the system to ensure compressor reliability.
6	One-way valve	Prevents high-pressure gas from entering the compressor and fast balances the suction pressure and discharge pressure in a compressor.
7	High-pressure sensor	Detects the high pressure value in the system in real time mode for compressor protection and other control functions.
8	Four-way valve 1	Used for the switching between the cooling and heating functions of system IDU.
9	Heat exchanger	Used for outdoor heat exchange.
10	Fan	Strengthens heat exchanging.
11	Defrosting temperature sensor	Used for defrosting detection.
12	Electronic expansion valve for heating	Controls refrigerant adjustment in heating mode.
13	One-way valve	Controls refrigerant flow direction.
14	Unloading valve	Opening if the pressure inside the liquid pipe /gas pipe is too high.
15	Sub cooler electronic expansion valve	Reduces the pressure and temperature of ramous refrigerant to cool the main branch refrigerant.
16	Sub cooler	Controls the degree of sub cooling of tube.
17	Liquid outlet temperature sensor of sub cooler	Detects tube temperature.
18	Middle-pressure sensor	Detects system middle pressure.
19	Gas outlet temperature sensor of sub cooler	Detects gas temperature of sub cooler.
20	Compensate vapor valve	Used for compensating vapor for second compression.
21	Sub-cooling valve	Used for providing with sub-cooling liquid.
22	Low-pressure sensor	Detects system low pressure to avoid extra-low operating pressure.
23	Gas-liquid separator	Separate gas and liquid to prevent the system from running when the refrigerant flows back to the compressor.
24	Outlet temperature sensor of gas-liquid separator	Detects internal status of gas-liquid separator to further control the compressor suction performance.
25	Oil return valve 1	Oil return control for the compressor.
26	Inlet temperature sensor of gas-liquid separator	Detects inlet temperature of gas-liquid separator.
27	Fusible plug	Opening if the pressure or the temperature inside the accumulator or liquid-gas separator is too high
28	One-way valve	Controls refrigerant flow direction.
29	One-way valve	Controls refrigerant flow direction.
30	Filter	Prevents impurities from entering components and parts.
31	Capillary tube	Supports flow regulating and pressure reduction.
32	Oil return valve	Oil return control for the compressor.
33	Pressure-balanced valve	Ensures success startup of compressor.
34	Varying capacity valve 1	To make the compressor turn with double cylinders.
35	Varying capacity valve 2	To make the compressor turn with triple cylinders.
36	Oil-balanced valve 1	Make sure oil of the system is balanced.
37	Oil-balanced valve 2	Make sure oil of the modules is balanced.

38	Gas-bypass valve	Make sure pressure of the system is balanced.
39	One-way valve	Prevents high-pressure gas from entering the compressor and fast balances the suction pressure and discharge pressure in a compressor.
40	Oil orifice	To charge compressor oil.
41	Gas pipe valve	Stop valve, closed when the unit is delivered from the factory and will be opened after installation.
42	Low-pressure measurement valve	Detects the low pressure value or charges refrigerant during system running.
43	Liquid pipe valve	Stop valve, closed when the unit is delivered from the factory and will be opened after installation.

4 EQUIPMENT SELECTION PROCEDURE

4.1 Selection Flow Chart

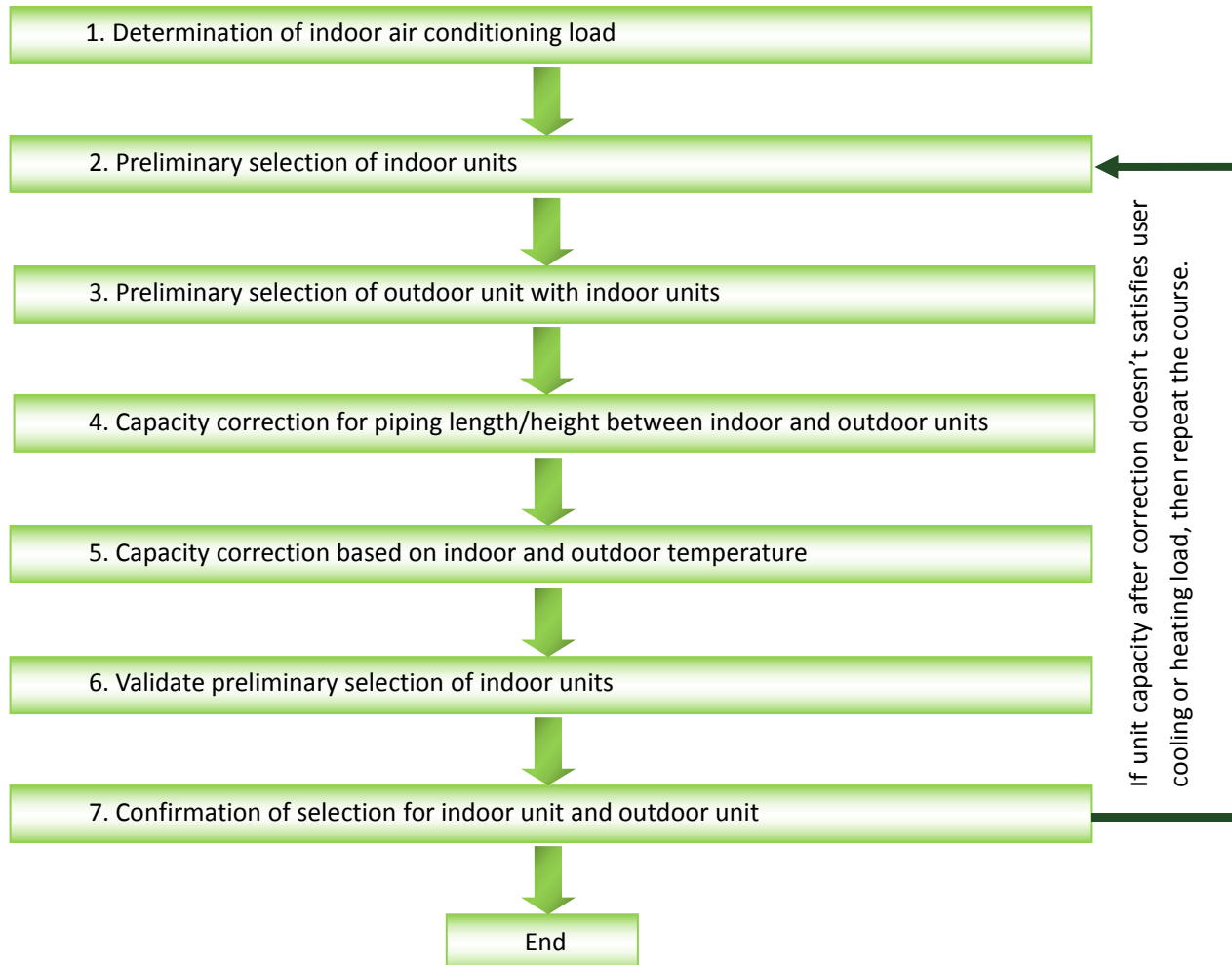

4.2 Combination Conditions for Indoor Unit and Outdoor Unit

- 1) The capacity code = the nominal cooling capacity (Btu/h) × 0.001.
- 2) For outdoor unit, MAX. Number of connectable indoor units and total capacity code of indoor units are decided.

Model Name of Outdoor Unit	Capacity Code of Outdoor Unit	MAX. Number of Indoor Units	Total Capacity Code of Indoor Units	MIN. Number of Indoor Units
GMV-V72W/A-F(U)	72	12	36 to 97	2
GMV-V96W/A-F(U)	96	17	48 to 129	2
GMV-V144WM/A-F(U)	144	24	72 to 194	2
GMV-V168WM/A-F(U)	168	29	84 to 226	2
GMV-V192WM/A-F(U)	192	34	96 to 258	2

4.3 Cooling/Heating Capacity Characteristics

4.3.1 Cooling capacity calculation method

Required cooling capacity = Cooling capacity × Factor ① × Factor ② kBTu/h

① Ambient Temperature VS. Capacity

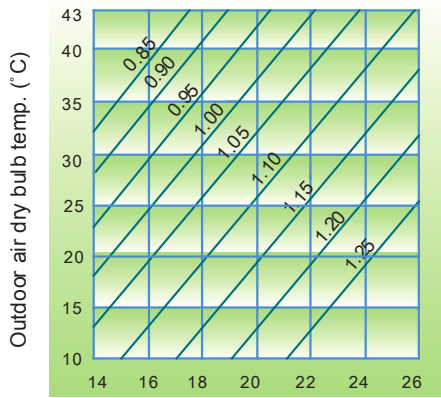

Indoor air wet bulb temp. (°C)

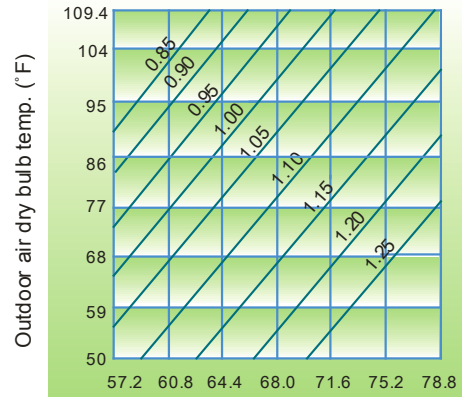

Indoor air wet bulb temp. (°F)

② Connecting Pipe Length and Height Difference Between Indoor and Outdoor Units VS. Capacity Correction Value

Value

- ✧ Hp: Height Difference Between Indoor and Outdoor Units (Outdoor unit higher)
- ✧ Hm: Height Difference Between Indoor and Outdoor Units (Outdoor unit lower)
- ✧ L: Equivalent Pipe Length

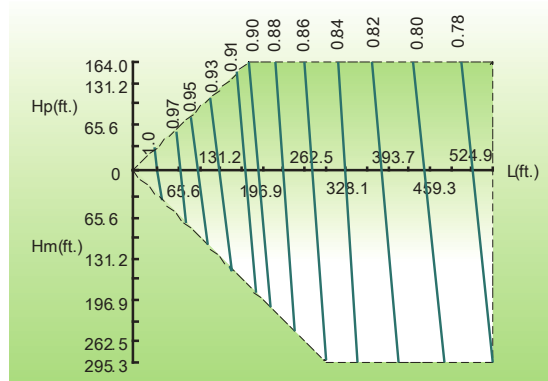
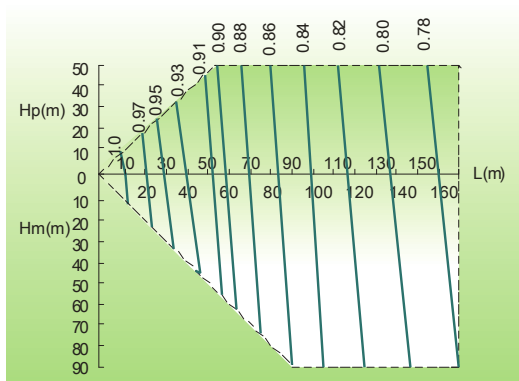

4.3.2 Heating capacity calculation method

Required heating capacity = Heating capacity × Factor ① × Factor ② kW

① Ambient Temperature VS. Capacity

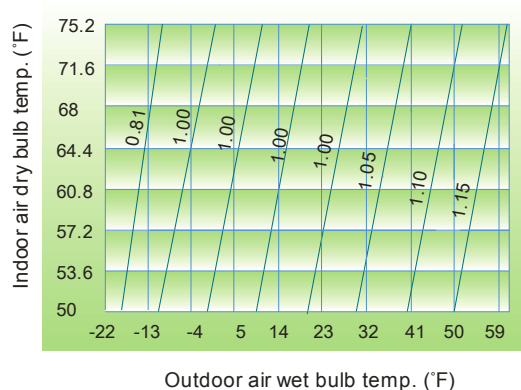
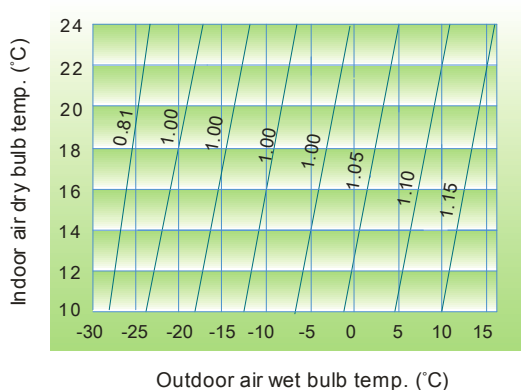

② **Connecting Pipe Length and Height Difference Between Indoor and Outdoor Units VS. Capacity Correction Value**

- ✧ Hp: Height Difference Between Indoor and Outdoor Units (Outdoor unit higher)
- ✧ Hm: Height Difference Between Indoor and Outdoor Units (Outdoor unit lower)
- ✧ L: Equivalent Pipe Length

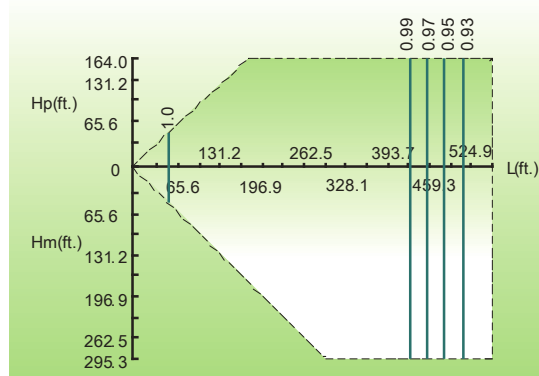
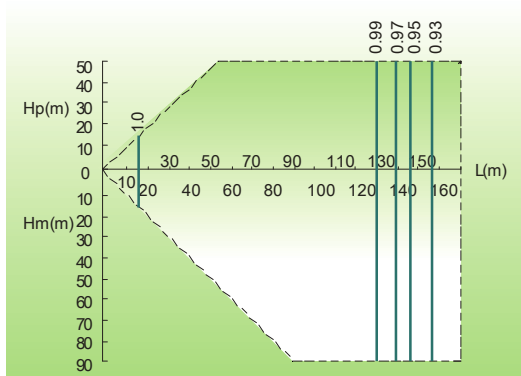

4.3.3 Capacity calculation for each indoor unit

Capacity for each indoor unit

$$= \text{Capacity after correction of outdoor unit} \times \frac{\text{Required standard capacity of indoor unit}}{\text{Total value of standard indoor unit capacity}}$$

4.3.4 Operating temperature range

Range	Mode	Outdoor Temperature Range °C (°F)
Cooling		-10~52 (14~125.6)
Heating		-30 ~24 (-22~75.2)

If the temperature is beyond the range, the safety protection measure of the unit may take effect, and the air conditioning unit will stop.

4.4 Example of Equipment Selection

4.4.1 Overview of building model

<Outside view>

<Stories configuration>

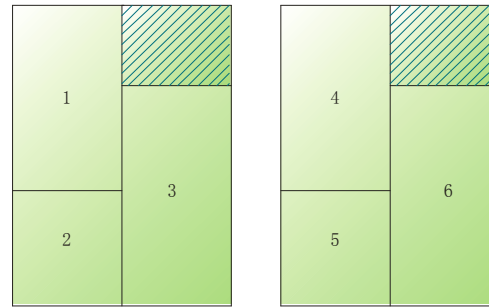
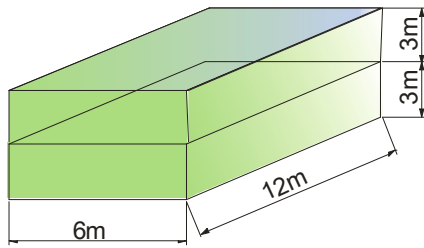

Steel frame, reinforced concrete building, two stories above ground.

An apartment area: 144m², each story area: 72 m².

Outdoor unit is installed on the balcony.

Cooling:

Design indoor conditions: 26.7°C (80.1°F)DB/19.4°C (66.9°F)WB

Design outdoor conditions: 35°C (95°F)DB/23.9°C (75°F)WB

4.4.2 Selection criteria for each apartment

Outdoor capacity exactly matches the total indoor capacity. Total indoor HP = Outdoor unit HP.

For example:

Indoor: 1.5HP+1HP+2HP=4.5HP

Outdoor: 5HP

4.4.3 Procedure and result of equipment selection

① Procedure of Equipment Selection

- ✧ Calculate cooling for every room.
- ✧ Select an indoor unit to match the cooling load for every room.
- ✧ Choose a tentative outdoor that will match with indoor units, perform capacity correction based on the pipe length, system lift, indoor set temperature, outdoor temperature, then make sure the corrected system cooling capacity satisfies the cooling load.

② Equipment Selection and Capacity Check

Air Conditioning Load			Equipment Selection					
Floor	Room No.	Indoor Cooling Load (kBtu/h)	Indoor Unit			Outdoor Unit		
			Model	Capacity (kBtu/h)		Model	Capacity (kBtu/h)	
				Cooling	Heating		Cooling	Heating
1F	1	6	GMV-ND07PLS/A-T(U)	7.5	8.5	GMV-V72W/A-F(U)	69	77
	2	11	GMV-ND12T/A-T(U)	12	13.5			
	3	14	GMV-ND14PLS/A-T(U)	14	15			
2F	4	7	GMV-ND07C/A-T(U)	7.5	8.5			
	5	8.5	GMV-N09G/A3A-D(U)	9.5	11			
	6	16.7	GMV-ND18TS/A-T(U)	18	20			

③ Schematic Diagram

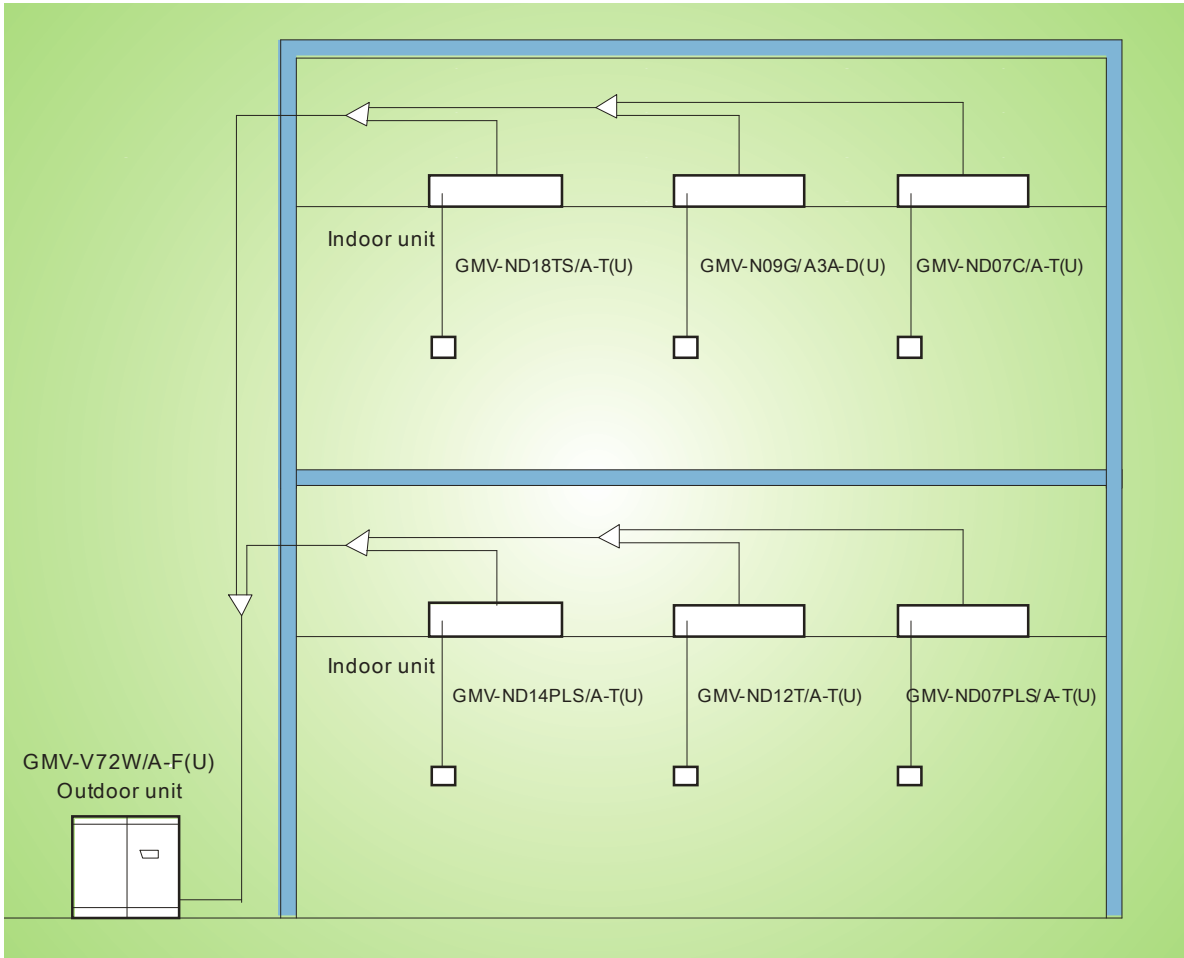

5 UNIT GRAVITY CENTER DIAGRAMS

Unit: mm

GMV-V72W/A-F(U), GMV-V96W/A-F(U):

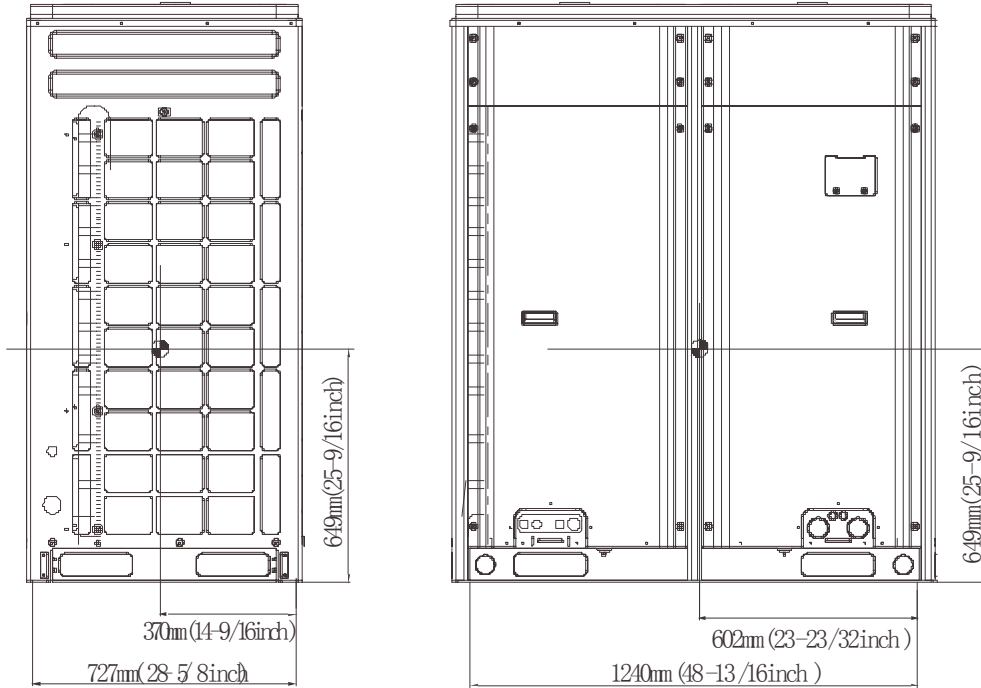

6 UNIT INSTALLATION SPACE REQUIREMENTS

6.1 Selection of Outdoor Unit Installation Site

VRF units are used in a lot of situations and serve wider users. If the unit is installed in a living environment, the cooling, heating and noise requirements will be higher, especially for the aged and infants. Therefore, the indoor/outdoor unit model with sufficient capacity and low noise should be preferred during model selection. It is not advisable to install the outdoor unit outside the bedroom, study room, or meeting room. For the commercial site, it is improper to install the outdoor unit near the office.

6.2 External Dimensions and Mounting Hole Dimensions of the Outdoor Unit

Unit: mm

External and installation dimensions of GMV-V72W/A-F(U), GMV-V96W/A-F(U):

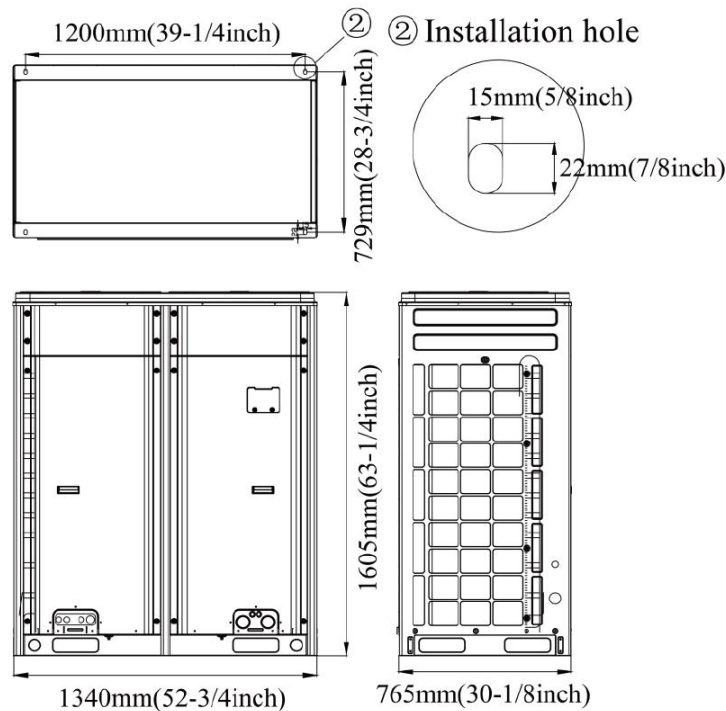

6.3 External Unit Installation Space Requirements

Unit: mm

1) Space requirement for the surround of outdoor unit

When the unit is surrounded by obstructions in four directions, please keep the distance between the unit top and the top wall at least 3000mm (118-1/8inch) or above. And keep the distance between the unit and the surrounded wall at least 1000mm (39-1/4inch) or above.

a) Space dimension for single-module unit

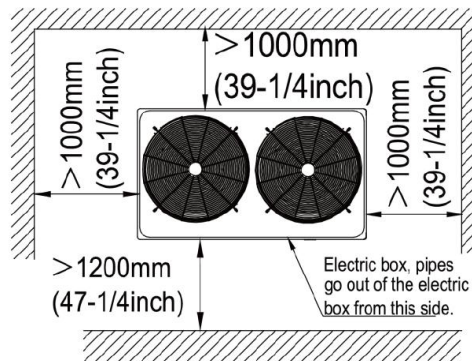
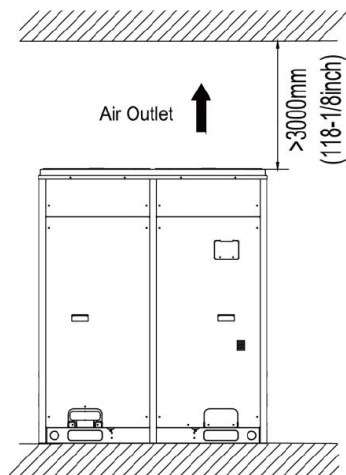

b) Space dimension for dual-module unit

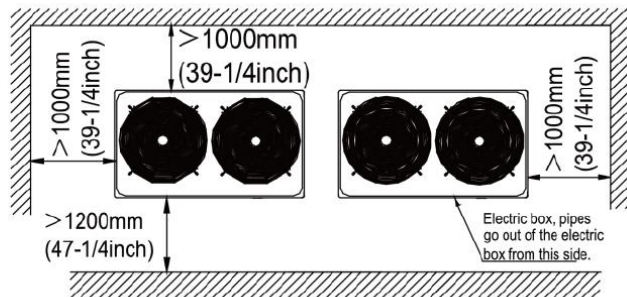
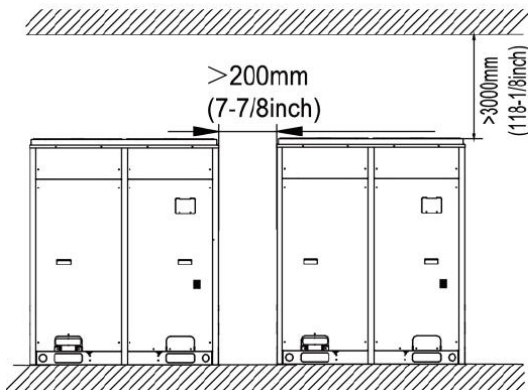

2) Space requirement for the top of outdoor unit

When the unit is located in a totally open space with no obstructions in four directions, keep the distance between the unit top and wall at least 1500mm (59inch) or above (See Fig.(a)). When space is limited within 1500mm (59inch) or the unit is not set in an open space, air return pipe is required to be installed in order to keep good ventilation (See Fig.(b)).

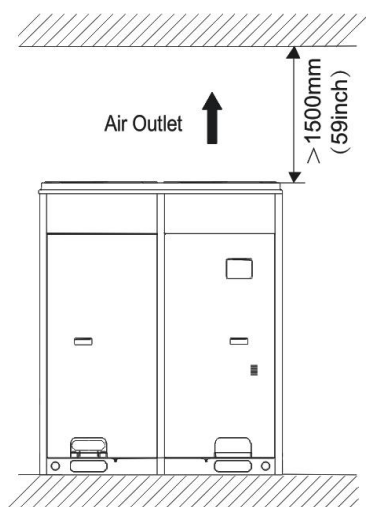

Figure (a)

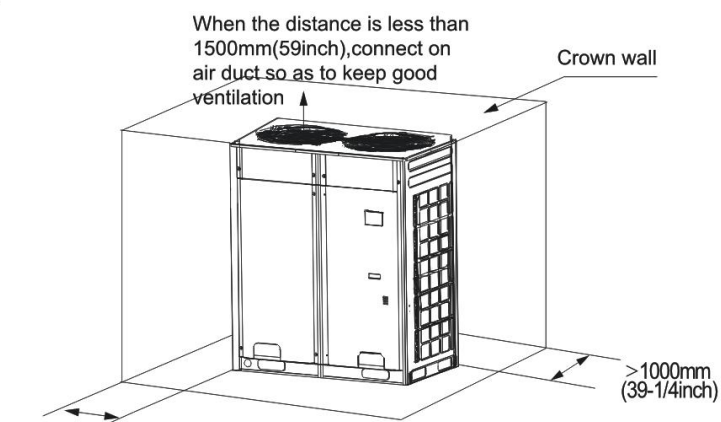

Figure (b)

3) Space dimension for multiple-module unit

For keeping good ventilation, make sure there are no obstructions above the unit.

When the unit is located at a half-open space (front and left/right side is open), install the unit as per the same or opposite direction.

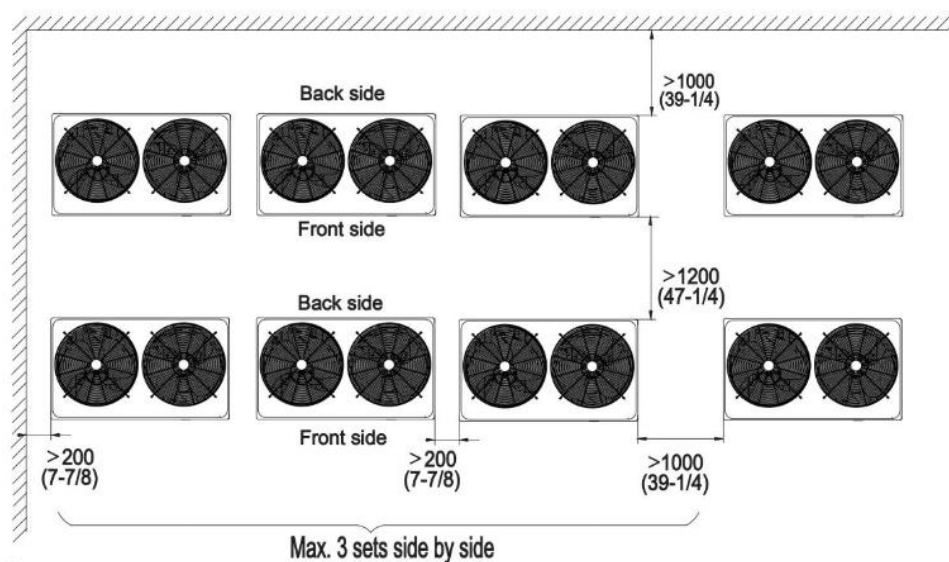
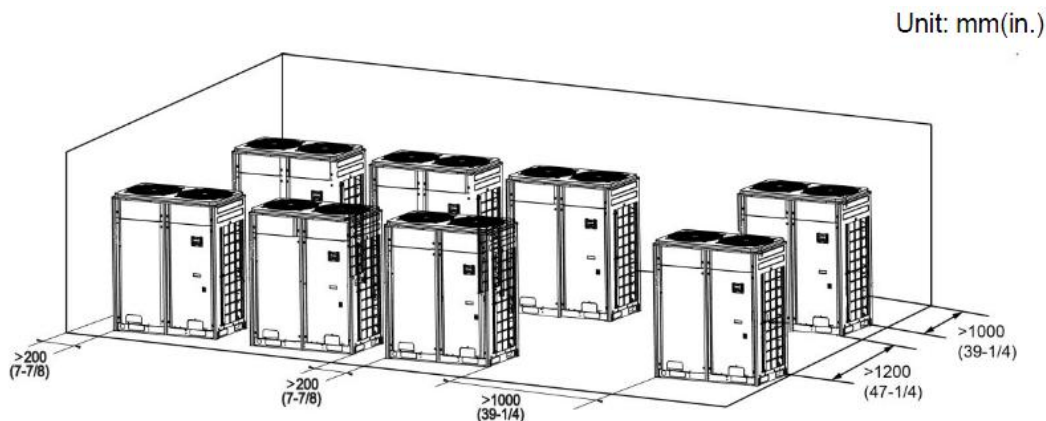
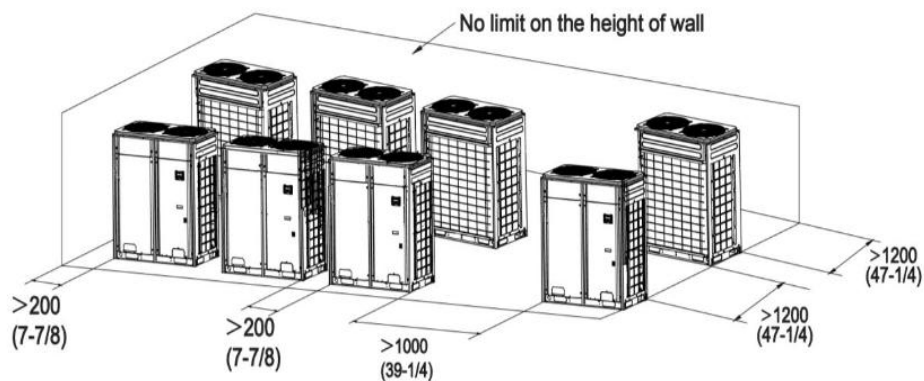

Fig.(a)



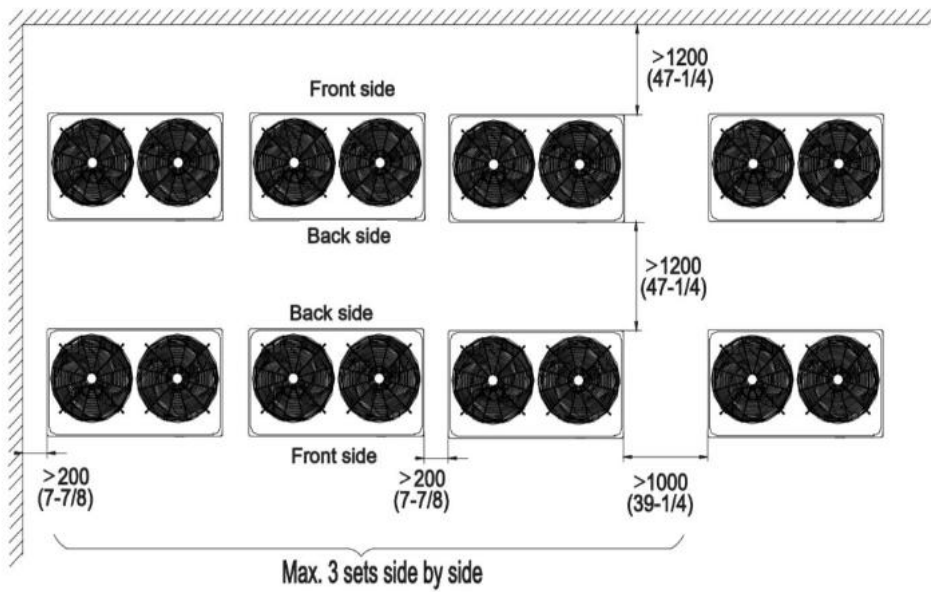
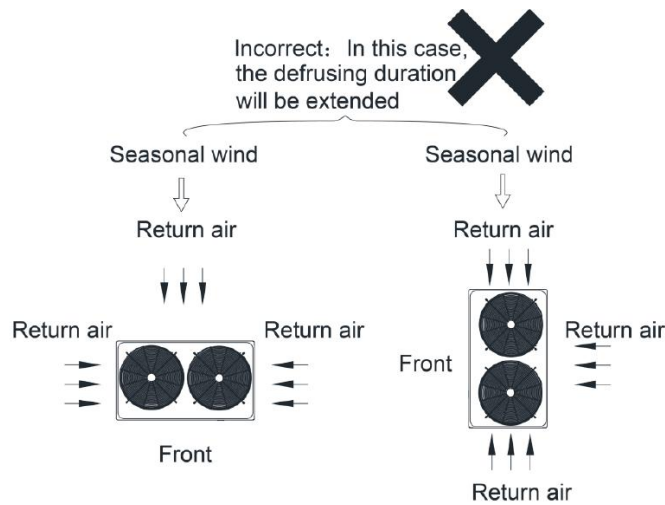
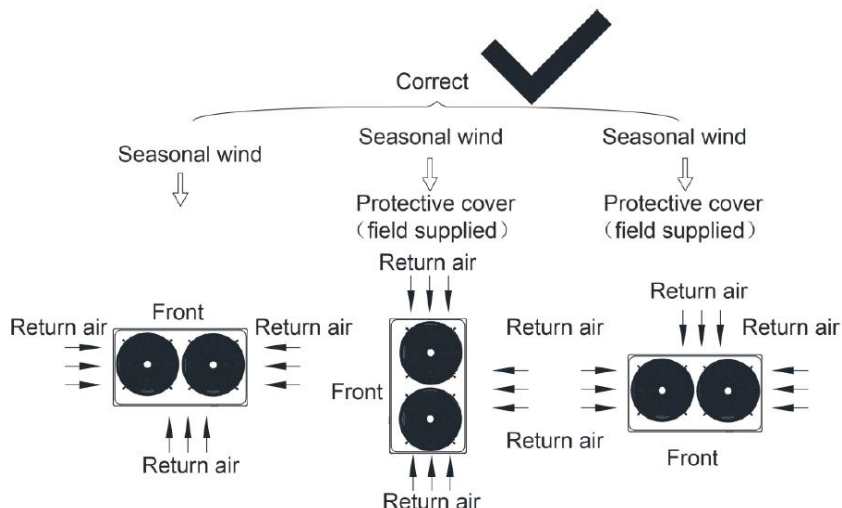

Fig.(b)

- 4) Take seasonal wind into consideration when installing the outdoor unit
 - a) Anti-monsoon installation requirements for unit not connecting exhaust duct





b) Anti-monsoon installation requirements for unit connecting exhaust duct

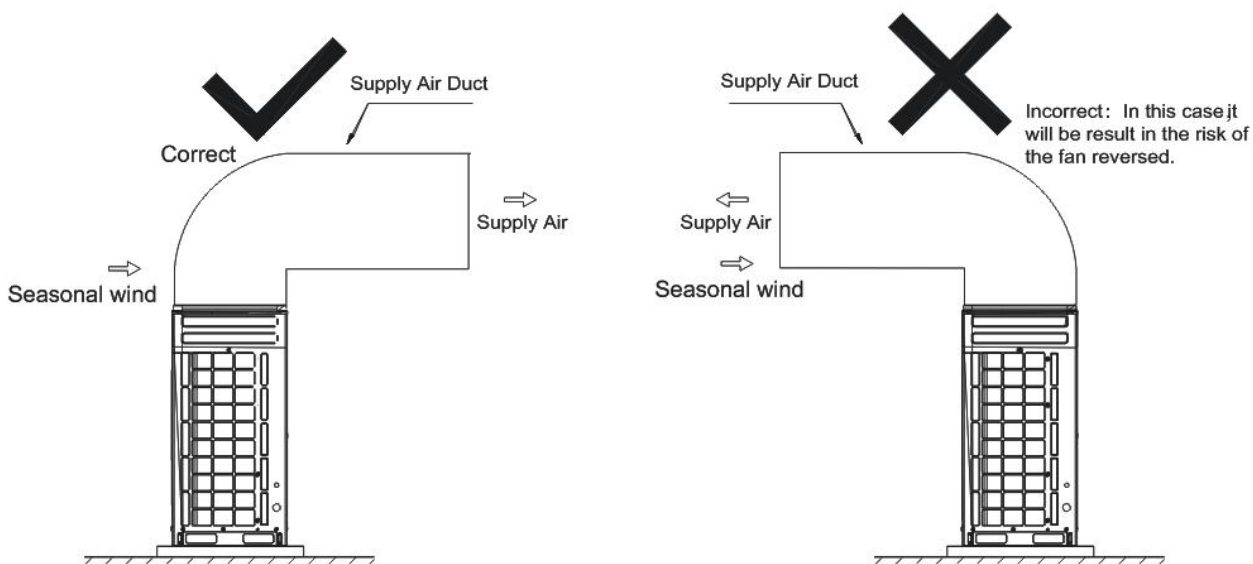

5) Take snow into consideration when installing the outdoor unit

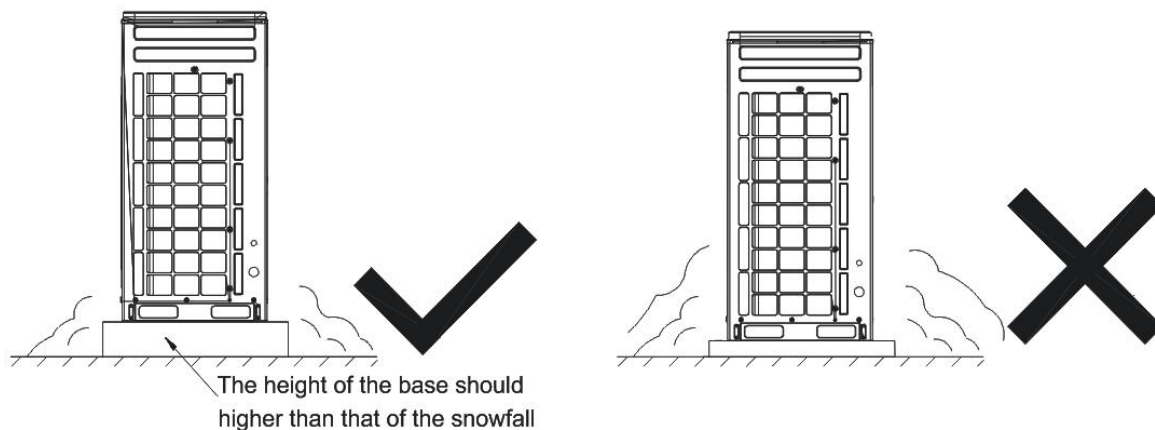

6) When the outdoor unit is installed on equipment, an air exhaust pipe should be connected, the aperture opening ratio of the louver cannot be smaller than 80%, and the included angle between the louver and the horizontal plane should be smaller than 20°.

7 MODEL SELECTION FOR UNIT PIPING

7.1 Schematic Diagram of Piping Connection

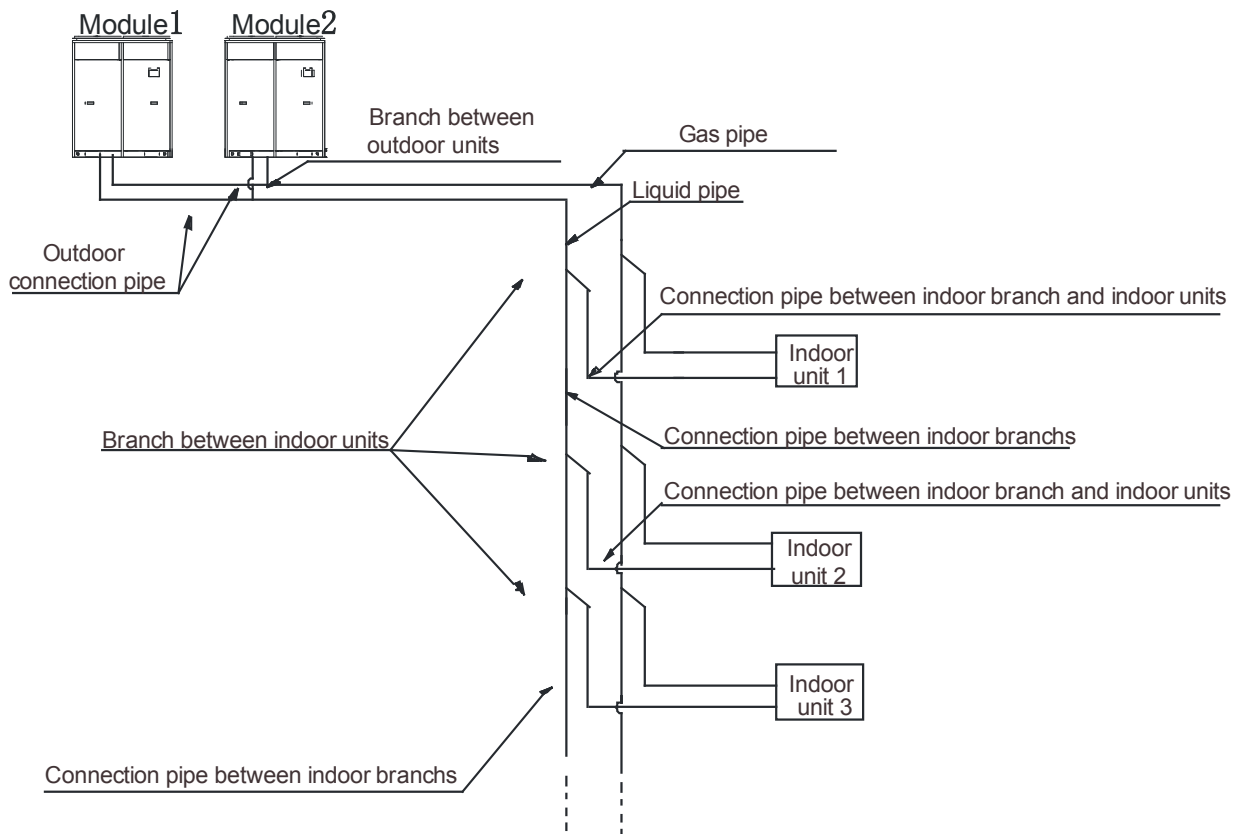

Schematic diagram of piping sequence of GMV-V72W/A-F(U) and GMV-V96W/A-F(U):

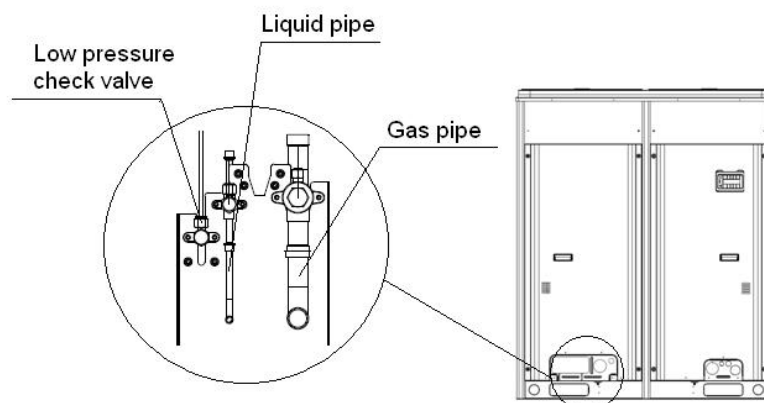

7.2 Allowable Pipe Length and Drop Height Among Indoor and Outdoor Units

Y type branch joint is adopted to connected indoor and outdoor units. Connecting method is shown in the figure below. Remark: equivalent length of one Y-type manifold is about 0.5m (1-3/4feet).

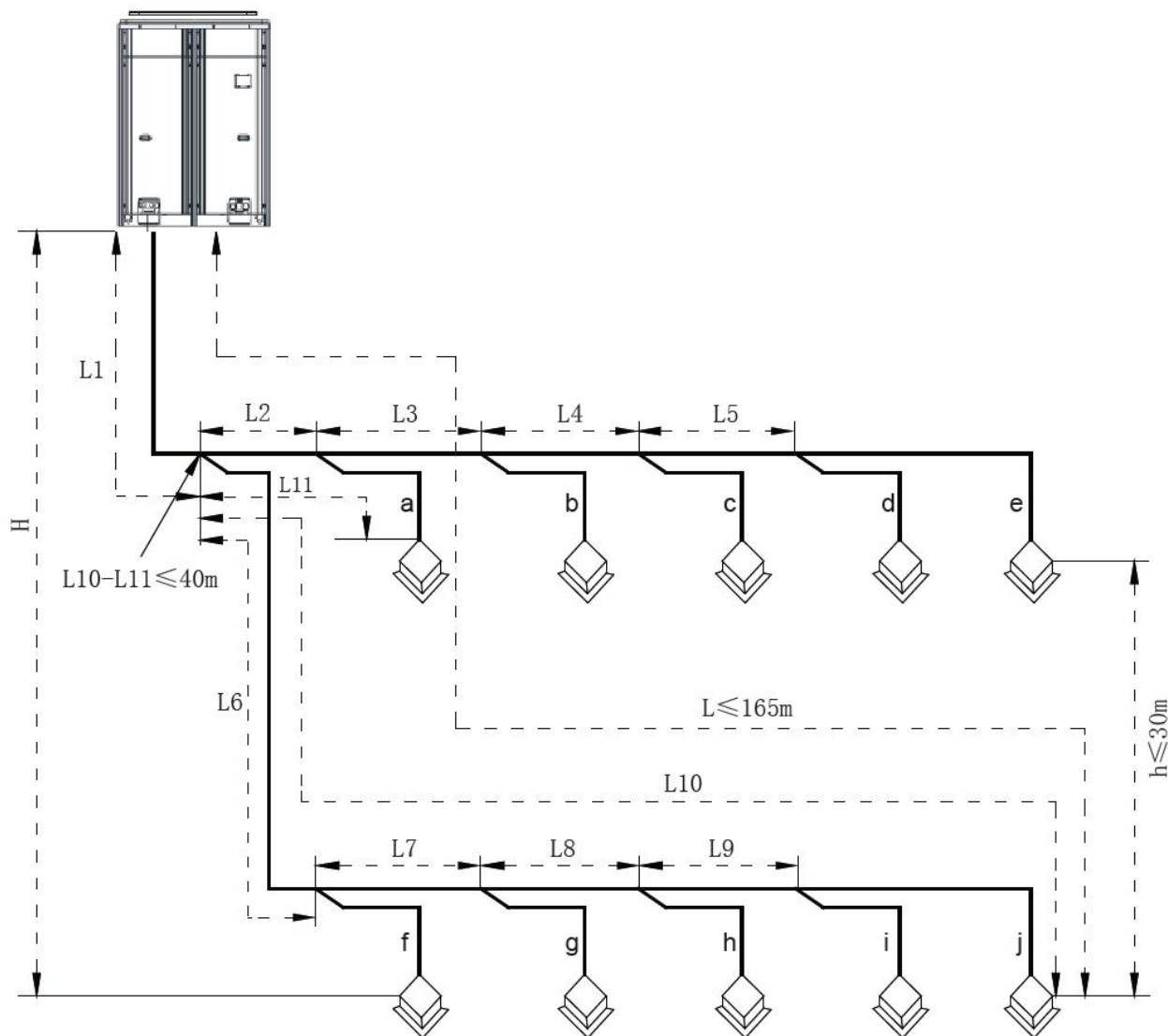

L10: Length from the first branch to the farthest IDU; L11: Length from the first branch to the nearest IDU; Equivalent length of branch of IDU is 0.5m (1-3/4feet).

R410A Refrigerant System		Allowable Value m(feet)	Fitting Pipe
Total length (actual length) of fitting pipe		≤1000(3280-3/4)	L1+L2+L3+L4+...+L9+a+b+...+i+j
Length of farthest fitting pipe m(feet)	Actual length	≤165(541-1/4)	L1+L6+L7+L8+L9+j
	Equivalent length	≤190(623-1/4)	
Difference between the pipe length from the first branch of IDU to the farthest IDU and the pipe length from the first branch of IDU to the nearest IDU		≤40(131-1/4)	L10-L11
Equivalent length from the first branch to the furthest piping (1)		≤40(131-1/4)	L6+L7+L8+L9+j
Height difference between outdoor unit and indoor unit	Outdoor unit at upper(2)	≤50(164)	--
	Outdoor unit at lower(2)	≤40(131-1/4)	--

Height difference between indoor units	≤15(49)	—
Maximum length of Main pipe(3)	≤90(295-1/4)	L1
From IDU to its nearest branch (4)	≤10(32-3/4)	a, b, c, d, e, f, g, h, i, j

Notices:

(1) Normally, the pipe length from the first branch of IDU to the farthest IDU is 40m (131-1/4feet). Under the following conditions, the length can reach 90m (295-1/4feet).

1) Actual length of pipe in total: $L1+L2 \times 2+L3 \times 2+L4 \times 2+...+L9 \times 2+a+b+...+i+j \leq 1000m$ (3280- 3/4feet).

2) Length between each IDU and its nearest branch a, b, c, d, e, f, g, h, i, j ≤ 40m (131- 1/4feet).

3) Difference between the pipe length from the first branch of IDU to the farthest IDU and the pipe length from the first branch of IDU to the nearest IDU: $L10-L11 \leq 40m$ (131-1/4feet).

(2) When the outdoor unit is at upper side and height difference is more than 50m, please consult company for the related technical requirement.

(3) When the maximum length of the main pipe from ODU to the first branch of IDU is $\geq 50m$ (164 ft), then adjust the pipe size.

Total rated capacity of ODU: C (Btu/h)	Pipe between outdoor unit and the first indoor branch	
	Gas pipe mm(inch)	Liquid pipe mm(inch)
GMV-V72W/A-F(U)	No need to enlarge pipe size	No need to enlarge pipe size
GMV-V96W/A-F(U)	No need to enlarge pipe size	No need to enlarge pipe size
GMV-V144WM/A-F(U)	No need to enlarge pipe size	Φ19.05(3/4)
GMV-V168WM/A-F(U)	No need to enlarge pipe size	Φ19.05(3/4)
GMV-V192WM/A-F(U)	No need to enlarge pipe size	Φ19.05(3/4)

(4) If the length between an IDU and its nearest branch is above 10m(32-4/5feet), then double the size of the liquid pipe of IDU (only for the pipe size that is ≤ 6.35mm(1/4inch)).

7.3 Connection pipe among outdoor modules

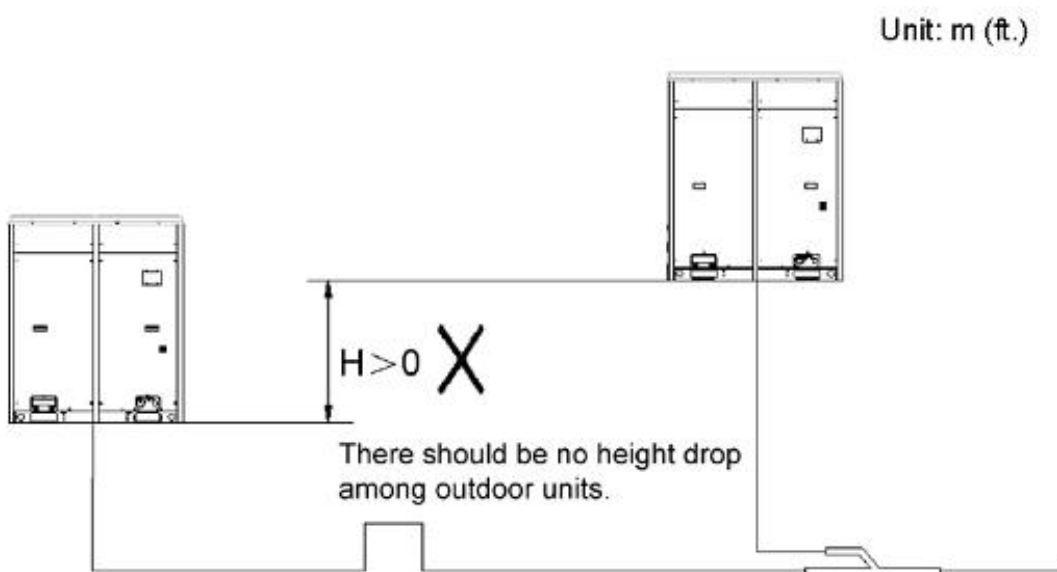

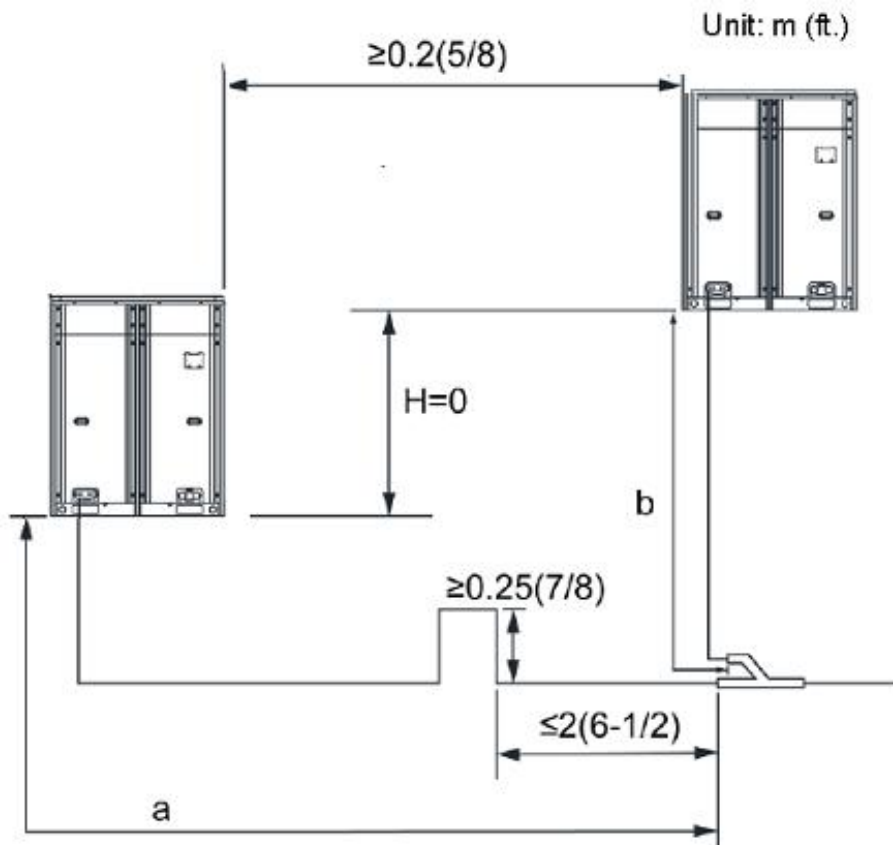

Note: when the distance between outdoor units exceeds 2m (6-1/2 feet), U-type oil trap should be added at low-pressure gas pipe. $a \leq 10\text{m}$ (32-7/8 feet); $b \leq 10\text{m}$ (32-7/8 feet).

7.4 Size Requirement for Branch Pipe and Piping (Main Pipe)

7.4.1 Connection sketch map of single-module system

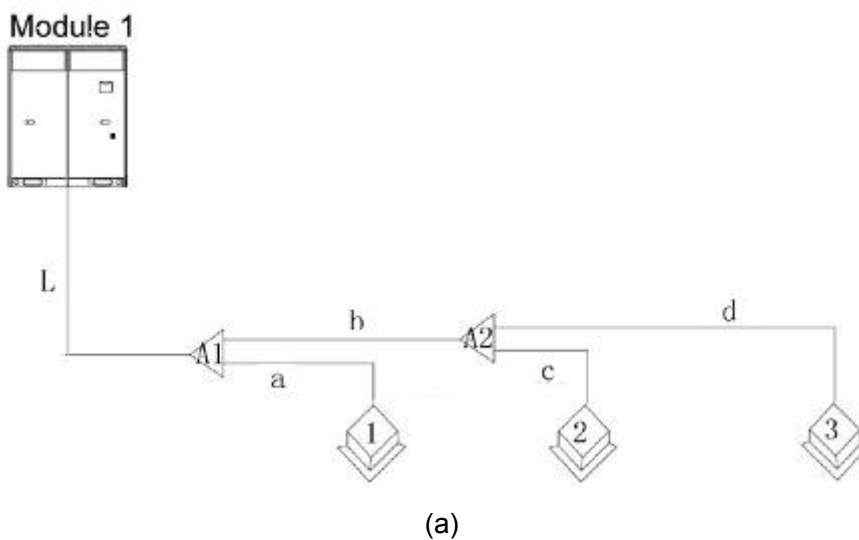

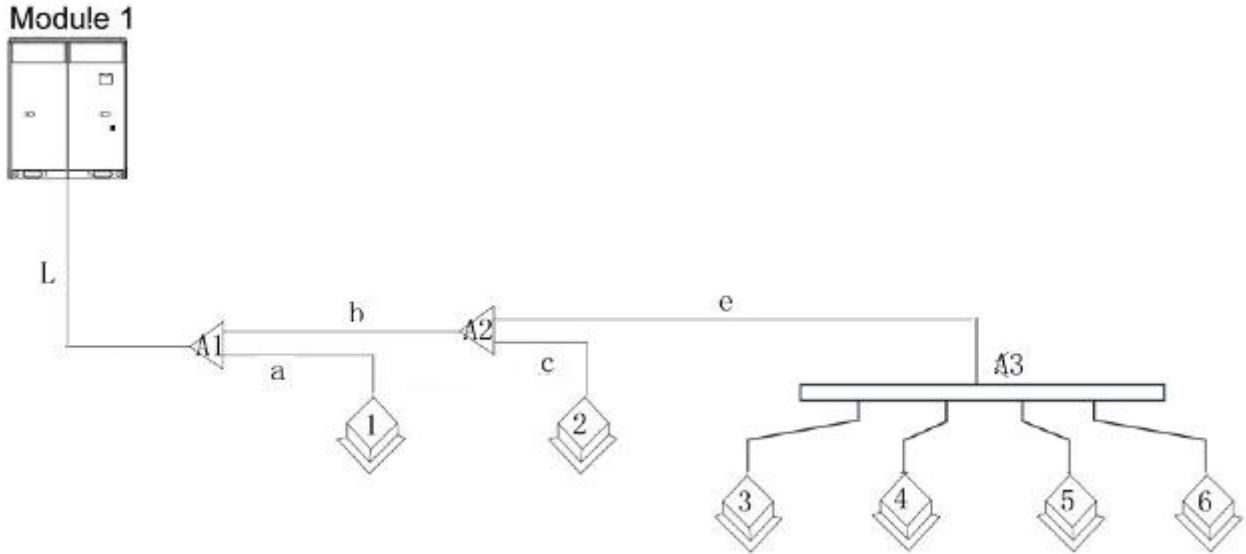

(b)

7.4.2 Connection sketch map of multi-module system

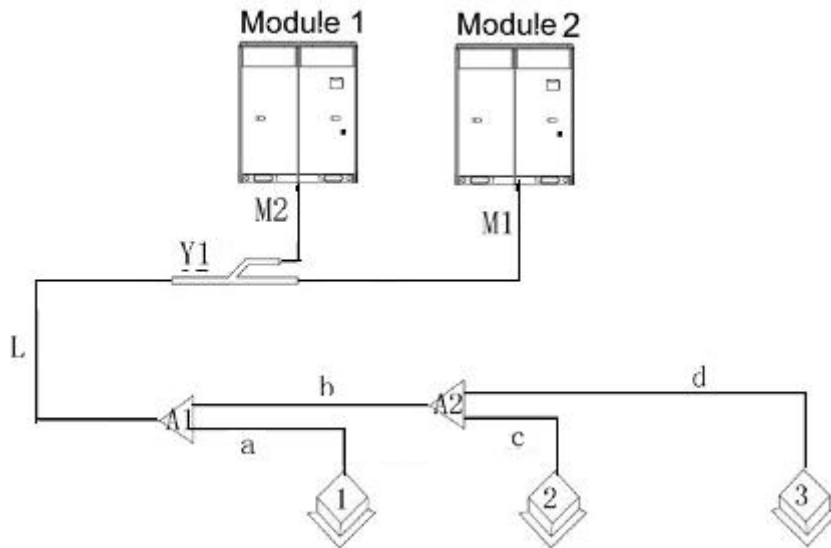

7.4.2 Select appropriate pipe between outdoor unit and the first indoor branch (“L”) as per the pipe size of outdoor unit.

Pipe between outdoor unit and the first indoor branch:

Basic module	Pipe between outdoor unit and the first indoor branch	
	Gas pipe mm(inch)	Liquid pipe mm(inch)
GMV-V72W/A-F(U)	Φ28.6(1-1/8)	Φ 12.7(1/2)
GMV-V96W/A-F(U)	Φ28.6(1-1/8)	Φ 12.7(1/2)

For multi-module, L pipe between the terminal outdoor branch and the first indoor branch:

Basic module	Pipe between outdoor unit and the first indoor branch
--------------	---

	Gas pipe mm(inch)	Liquid pipe mm(inch)
GMV-V144WM/A-F(U)	Φ34.9(1-3/8)	Φ15.9(5/8)
GMV-V168WM/A-F(U)	Φ34.9(1-3/8)	Φ15.9(5/8)
GMV-V192WM/A-F(U)	Φ34.9(1-3/8)	Φ15.9(5/8)

7.4.3 For multi-module system, select appropriate branch (“M1, M2”) connected to outdoor module as per the pipe size of basic outdoor module.

Pipe between module and outdoor branch “M1, M2”:

Basic module	Pipe between outdoor unit and the first indoor branch	
	Gas pipe mm(inch)	Liquid pipe mm(inch)
GMV-V72W/A-F(U)	Φ28.6(1-1/8)	Φ12.7(1/2)
GMV-V96W/A-F(U)	Φ28.6(1-1/8)	Φ12.7(1/2)

Selection of branch “Y1” of outdoor modules:

Module’s capacity (C) (Btu/h)	Model
$C \geq 144000$	ML01/A

7.4.4 Branch selection of the indoor unit side (“A1, A2, A3”)

Manifold at indoor unit side can be selected as per total capacity of downstream indoor unit(s).

Please refer to the following table.

R410A refrigerant system	Total Capacity of the Downstream Indoor Unit X(Btu/h)	Model
Y-type Branch Pipe	$C \leq 68000$	FQ01/A/A
	$68000 < C \leq 102000$	FQ02/A
	$102000 < C \leq 239000$	FQ03/A
	$239000 < C$	FQ03/A
T-type Branch Pipe	$C \leq 136000$	FQ014/H1
	$136000 < C \leq 232000$	FQ018/H1
	$232000 < C$	FQ018/H2

7.4.5 Piping size among upstream branches (“b, e”)

Total rated capacity of downstream indoor units: X(Btu/h)	Size of connection pipe between branches	
	Gas pipe mm(inch)	Liquid pipe mm(inch)
$X \leq 17100$	Φ12.7(1/2)	Φ6.35(1/4)
$17100 < X \leq 48500$	Φ15.9(5/8)	Φ9.52(3/8)
$48500 < X \leq 72000$	Φ19.05(3/4)	Φ9.52(3/8)
$72000 < X \leq 96000$	Φ22.2(7/8)	Φ9.52(3/8)
$96000 < X \leq 144000$	Φ28.6(1-1/8)	Φ12.7(1/2)
$144000 < X \leq 216000$	Φ28.6(1-1/8)	Φ15.9(5/8)

216000 < X ≤ 240000	Φ34.9(1-3/8)	Φ15.9(5/8)
240000 < X ≤ 336000	Φ34.9(1-3/8)	Φ19.05(3/4)
336000 < X	Φ41.3(1-5/8)	Φ19.05(3/4)

7.4.6 Piping between branch and indoor unit (“a、c、d”)

Rated capacity of indoor units: X ((Btu/h)	Size of connection pipe between indoor branch and indoor unit	
	Gas pipe mm(inch)	Liquid pipe mm(inch)
X ≤ 9500	Φ9.52(3/8)	Φ6.35(1/4)
9500 < X ≤ 17100	Φ12.7(1/2)	Φ6.35(1/4)
17100 < X ≤ 48500	Φ15.9(5/8)	Φ9.52(3/8)
48500 < X ≤ 72000	Φ19.05(3/4)	Φ9.52(3/8)
72000 < X	Φ22.2(7/8)	Φ9.52(3/8)

7.5 Attention before operation

The installer should read the following items, and make sure that the metal parts supplied for transportation are taken down.

- 1) For safe handling, two metal parts are fixed at the feet of compressor before delivery (shown as follows):

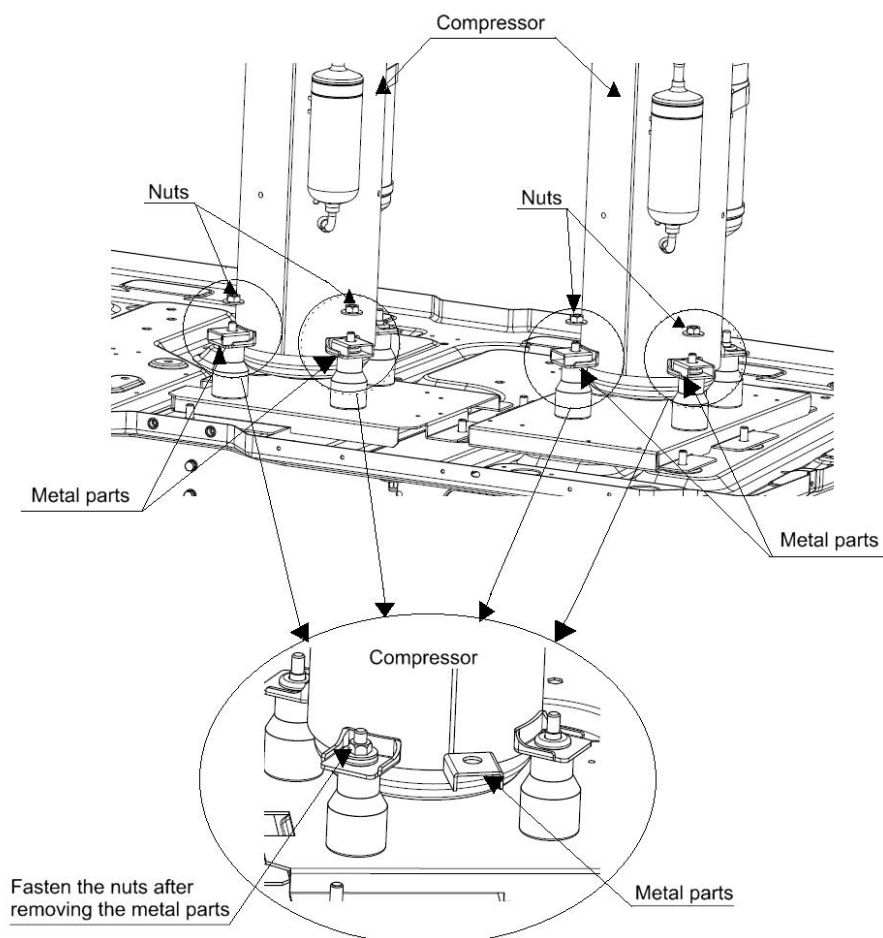

2) While installation, please make sure the metal parts are taken down. Then fasten the compressor fixed nuts again and re-wrap the soundproof material.



Note: if the unit is operating with the metal parts stay, it may lead to compressor abnormal vibration; even reduce the lifespan of the unit.

8 REQUIREMENTS FOR COMMUNICATION MODE

Ultra Heat GMV unit air conditioning system adopts the CAN communication network. Manual dialing and differentiation of the communication cable polarity are not required for the indoor unit, and only functional dialing should be set for the indoor unit.

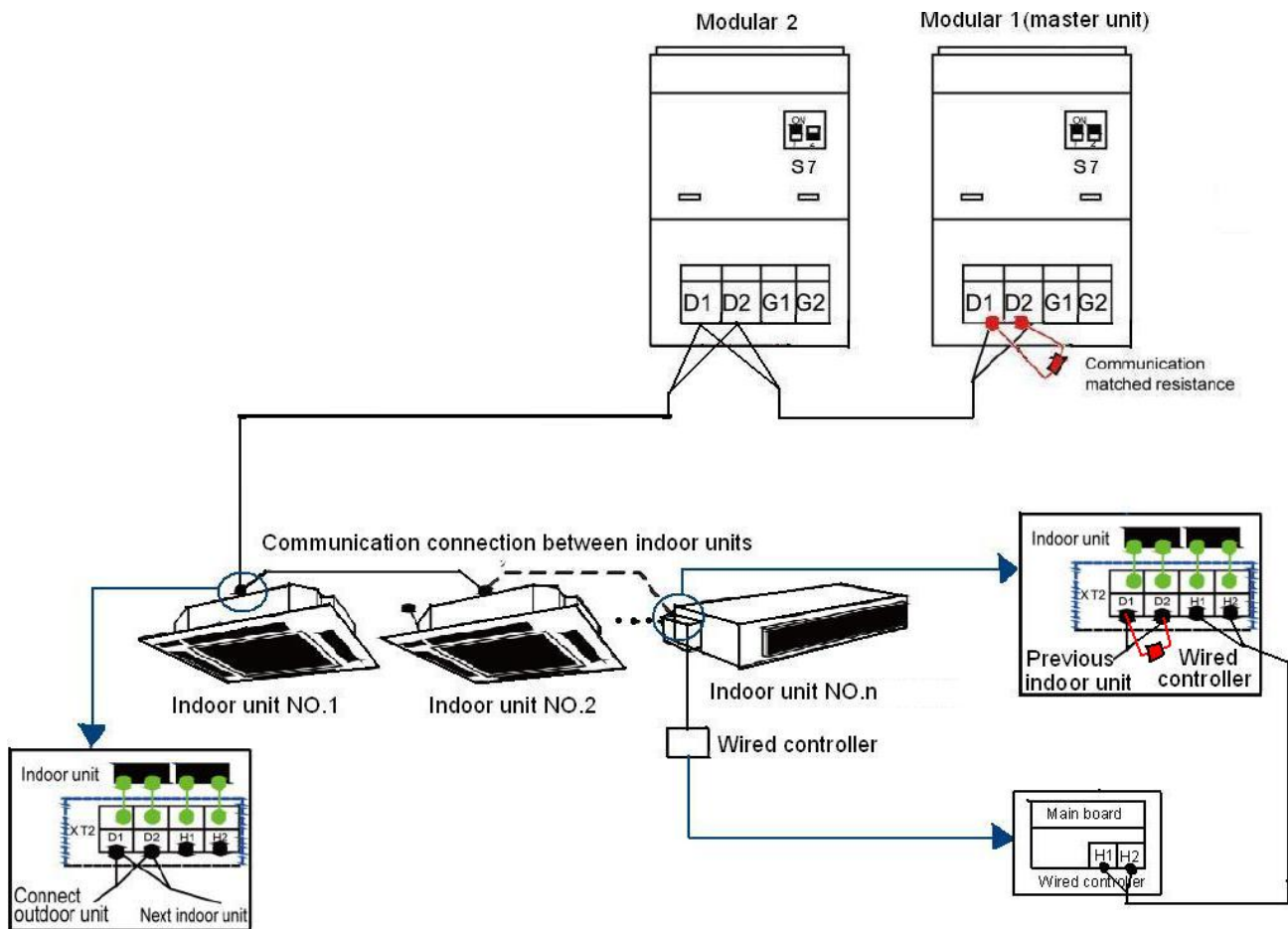

8.1 Connection Mode of Connection Line Terminals

All communication wires of Ultra Heat GMV units are connected by screws.

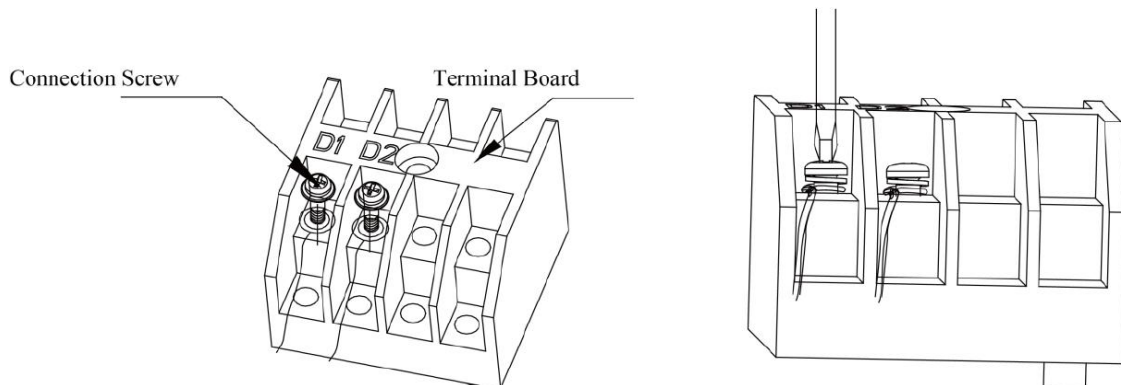

8.2 Communication Cable Material and Wring Mode

8.2.1 Communication material

➤ Select communication wire between ODU and IDU.

Material Type	Total Length L(m) of Communication Cable between IDU Unit and IDU (ODU) Unit m(feet)	Wire size	Remarks
Light/Ordinary polyvinyl chloride sheathed cord.	$L \leq 1000(3280-5/6)$	$\geq 2 \times \text{AWG}18$	1. If the wire diameter is enlarged to $2 \times \text{AWG}16$, the total communication length can reach 1500m (4921-1/4feet). 2. The cord shall be Circular cord (the cores shall be twisted together). 3. If unit is installed in places with intense magnetic field or strong interference, it is necessary to use shielded wire.

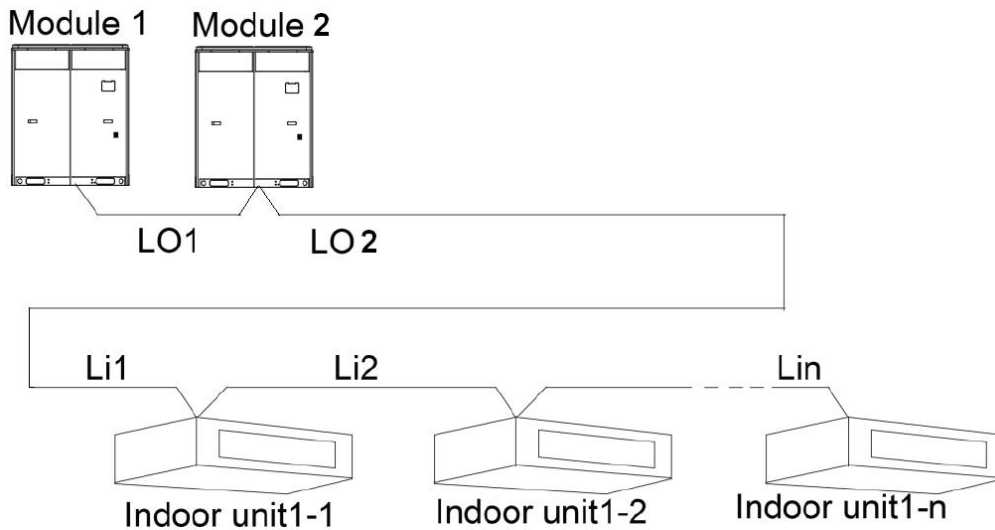

➤ Select communication wire between IDU and wired controller.

Material type	Total length of communication line between IDU unit and wired controller L m(feet)	Wire size	Remarks
Light/Ordinary polyvinyl chloride sheathed cord.	$L \leq 250(820-1/5)$	$2 \times \text{AWG}18 \sim 2 \times \text{AWG}16$	1. Total length of communication line can't exceed 250m (820-1/5feet). 2. The cord shall be Circular cord (the cores shall be twisted together). 3. If unit is installed in places with intense magnetic field or strong interference, it is necessary to use shielded wire.

For example, two wired controllers control multiple IDUs and the graphic of connection between IDU and wired controller is:

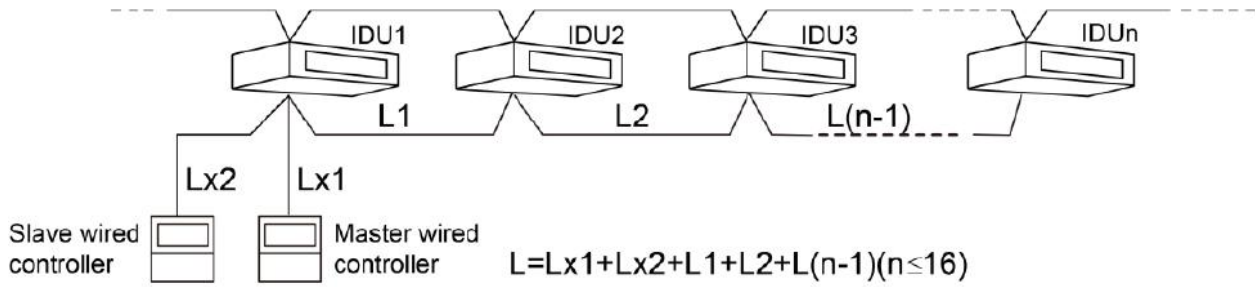

Notes: If the air conditioning units are installed at a place with strong electromagnetic interference, a shielded cable must be used as the communication cable between the indoor unit and wired controller, and a shielded twisted pair must be used as the communication cable between the indoor unit and indoor (outdoor) unit.

8.2.2 Communication access mode

The communication bus of Ultra Heat GMV indoor and outdoor units must be connected in series, and star connection is forbidden. The indoor unit at the end of the communication bus for the indoor units and outdoor units must be connected to a communication matching resistor (which is contained in the packing bag of the outdoor unit).

(1) All communication wires of Ultra Heat GMV must be connected in series rather than in star.

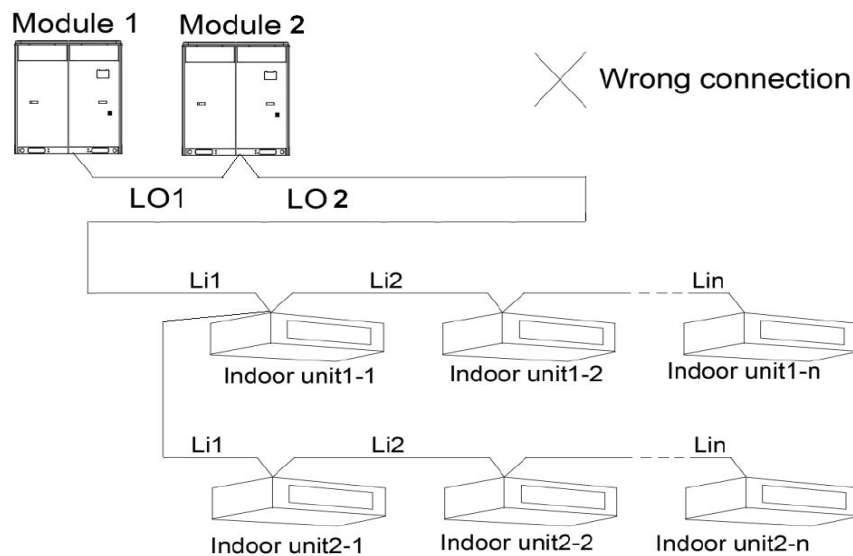
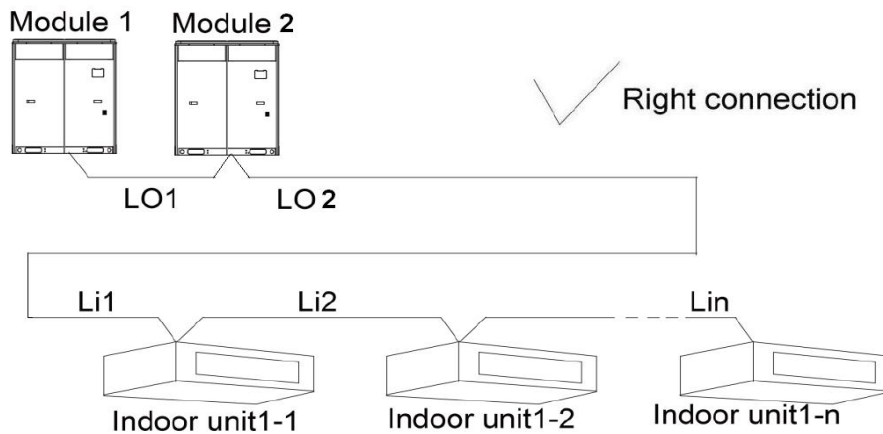

(2) All communication wires of Ultra Heat GMV units are connected by screws.

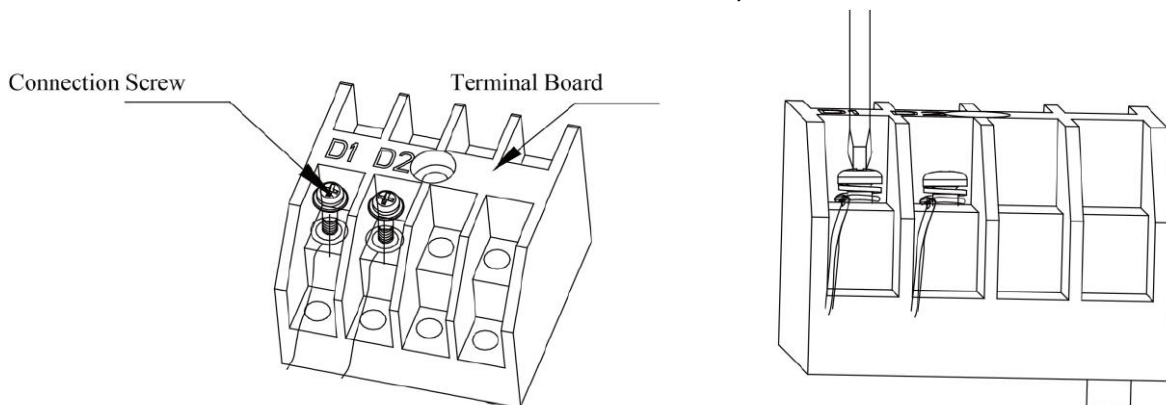

(3) If a single communication wire is not long enough and needs to be connected, the connected joint must be welded or pressure-welded. Do not simply twist the wires together.

8.3 Connection Method and Procedure of Communication Cable

8.3.1 Communication connection between the indoor unit and outdoor unit

The indoor unit is connected to the outdoor unit through the D1/D2 port of the terminal plate XT2. The figures below show the connection method of the single outdoor unit and connection method of the modular outdoor unit.

Communication connection mode of the single module system

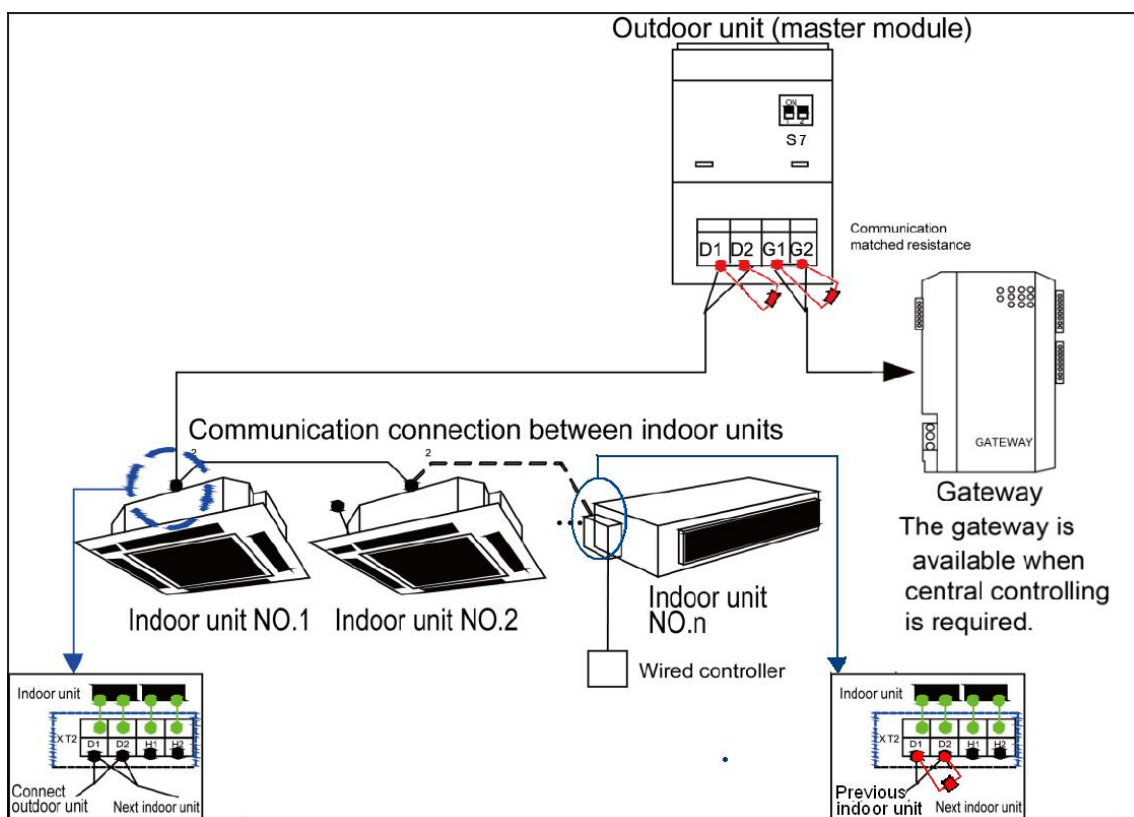

Connection of communication for multi-module system:

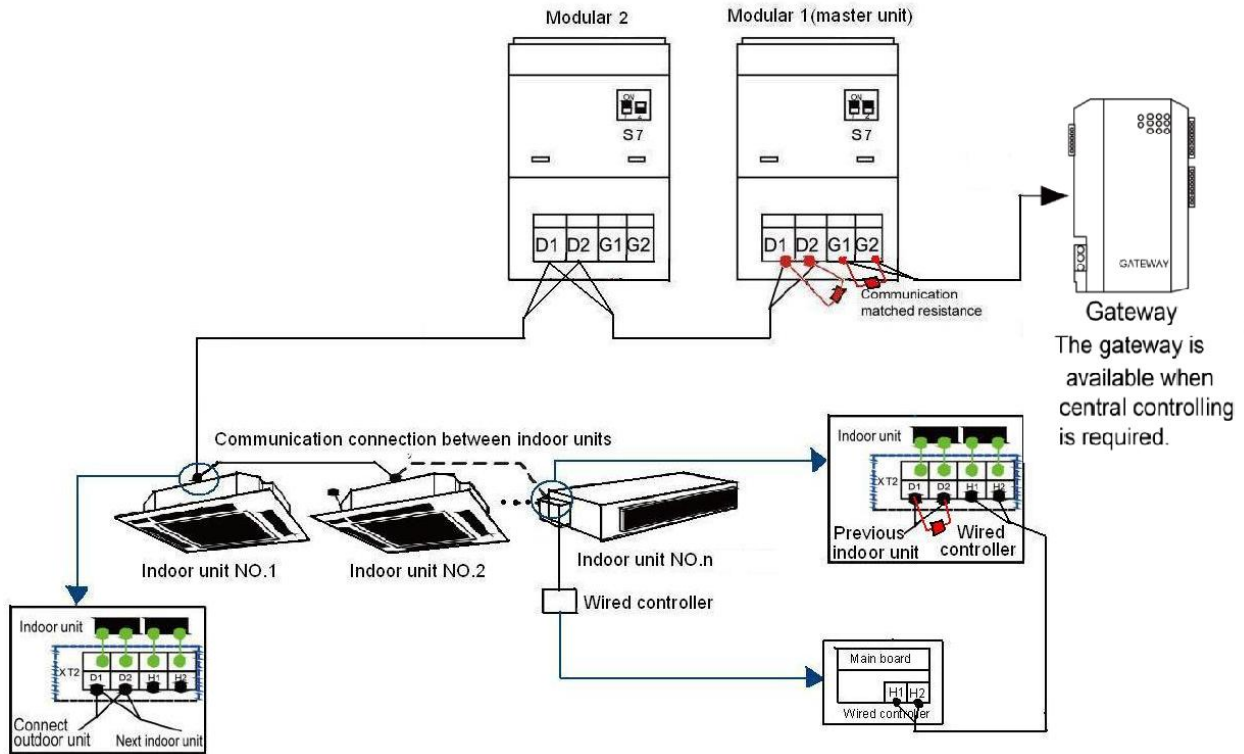

Connection of communication for multi refrigeration systems:

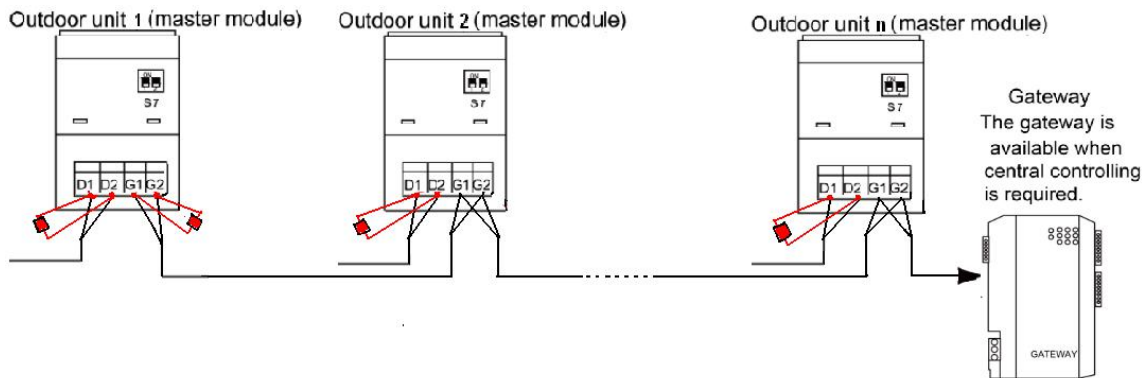

NOTICE

- (1) Communication wire and power cord must be separated.
- (2) Communication wire must be of proper length. Extension is not allowed.
- (3) IDUs must be connected in series. The last IDU D1/D2 must be connected with the communication matched resistance (supplied in the list of ODU spare parts). The ODU D1/D2 must be connected with the communication matched resistance (installed before factory).
- (4) For modular outdoor units, if there are multiple outdoor modules, then the master unit must be the first outdoor module on the communication wire and should not connect with IDU (master unit is set by S7 of the outdoor main board).
- (5) For modular outdoor units, if there are multiple outdoor modules, then indoor units must be connected with the last slave module of ODU (slave module is set by S7 of the outdoor main board).

(6) For modular outdoor units, if there are multiple outdoor modules, the communication matched resistance (installed before factory) of slave modules connecting with D1/D2 must be removed.

(7) For modular outdoor units, if there are multiple outdoor modules, S7 dip switch of master unit is "00", and S7 dip switch of slave unit is "10", otherwise, the system main board will display CJ which means address DIP switch code of system is shocking.

(8) For multi-refrigeration systems, when it is necessary to connect with a centralized controller, the communication lines connecting with all the ODUs G1/G2 must be connected in series, and the last refrigeration system master unit G1/G2 must be connected with the communication matched resistance (supplied in the list of ODU spare parts).

(9) For multi-refrigeration systems, the address dip switch S3 of the master unit must be set by different numbers according to Ultra Heat technical service manual, and slave unit S3 can't be set.

8.3.2 Communication connection mode between the indoor unit and wired controller

The indoor unit and the wired controller are connected in one of the following four modes, which are respectively shown in Figure below:

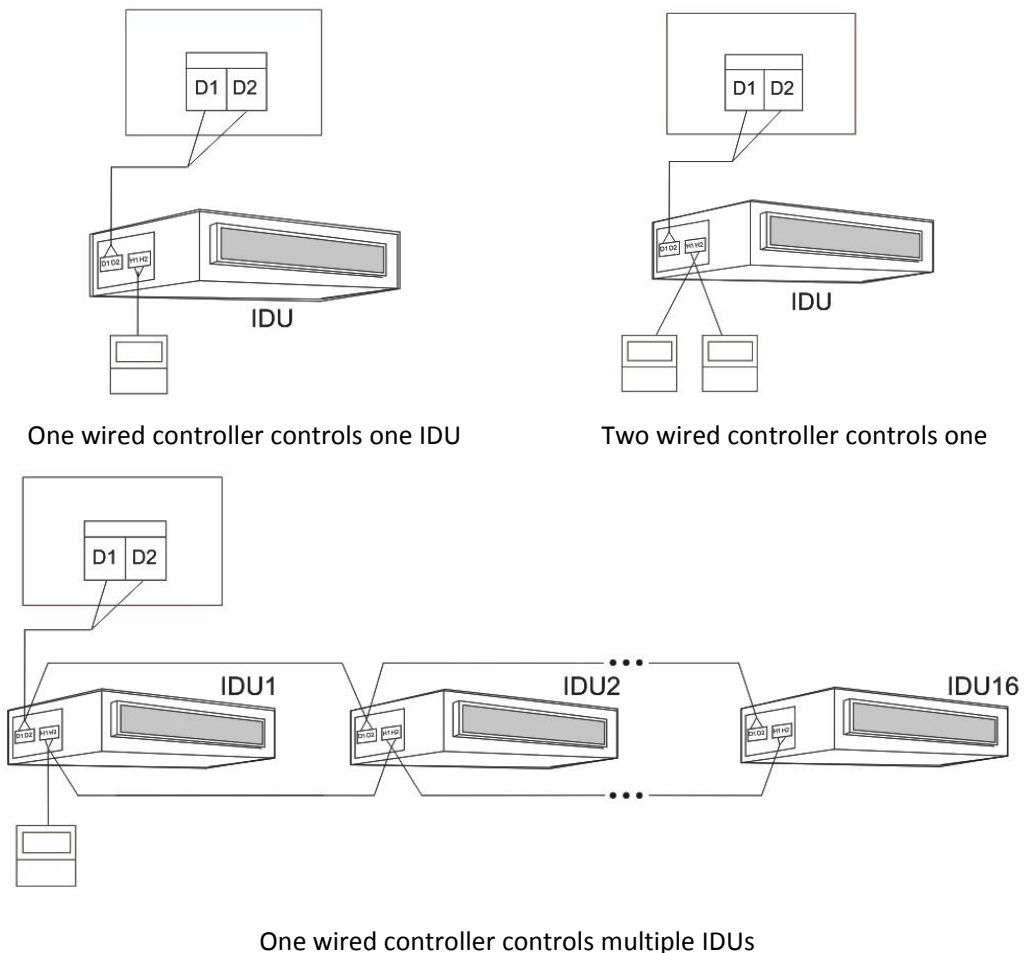

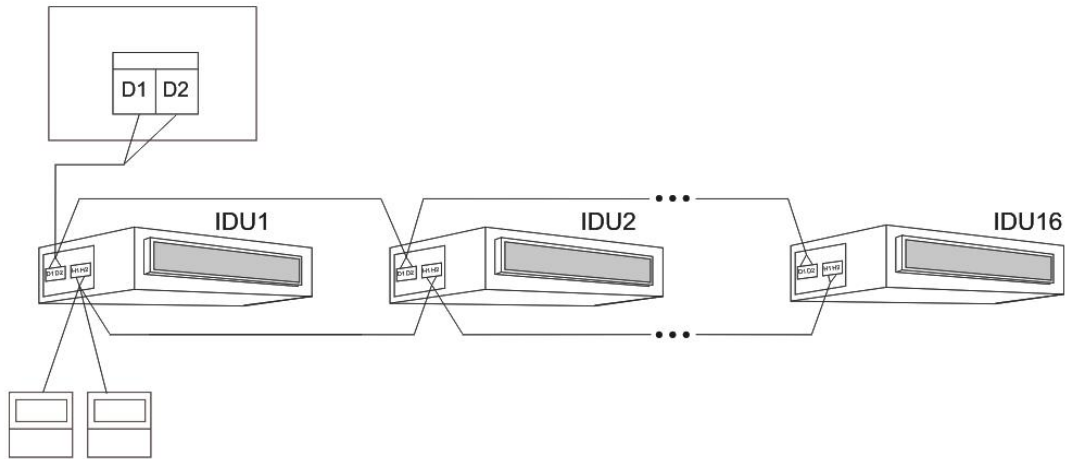

Two wired controllers control multiple IDUs

When two wired controllers control multiple indoor units at the same time, the wired controllers can be connected to any indoor unit, the connected indoor units must belong to the same series, and only one wired controller must be set to a slave wired controller. The number of indoor units controlled by the two wired controllers is not more than 16, and the connected indoor units must be on the same indoor unit network.

(1) The slave wired controller can be set in the power-on or power-off status:

(2) Press and hold the “FUNCTION” button on the wired controller to be set to a slave wired controller for five seconds. The temperature area displays “C00”. Continue holding the “FUNCTION” button for five seconds to enter the wired controller parameter setting interface. The temperature area displays “P00” by default.

(3) Select a P13 parameter code by pressing “▲” or “▼”. Press the “MODE” button to switch to parameter value settings. The parameter value blinks. Press “▲” or “▼” to select “02”, and then press the “ENTER/CANCEL” button to complete settings.

(4) Press the “ENTER/CANCEL” button to return to the upper-level menu till quitting parameter settings. The user parameter setting list is as follows:

Parameter code	Parameter name	Parameter scope	Default value	Remark
P13	Set up address for wired controller	01: master wired controller 02: slave wired controller	01	When 2 wired controllers control one or more IDUs, they shall have different addresses. Slave wired controller (02) can't set up units' parameters except its own address.



Note:

- a. The default factory setting of all the wired controllers is the master wired controller status.
- b. In the parameter setting status, the “FAN”, “Timer”, “SLEEP”, and “SWING” buttons are invalid. By pressing “ON/OFF”, you can return to the main interface but will not power on/off the unit.
- c. In the parameter setting status, signals of the remote controller are invalid.

8.3.3 Connection mode between the air duct-type indoor unit and receiving LED panel

When the air duct-type indoor unit needs to be connected to a remote receiving LED panel, they are connected through Dsp1 and Dsp2 of the main board for indoor unit:

IDU type	Connection wire	Main board interface of corresponding IDU
Duct type IDU	Between boards (17-core)	Dsp1 (direct to 8-core interface) Dsp2 (direct to 9-core interface)

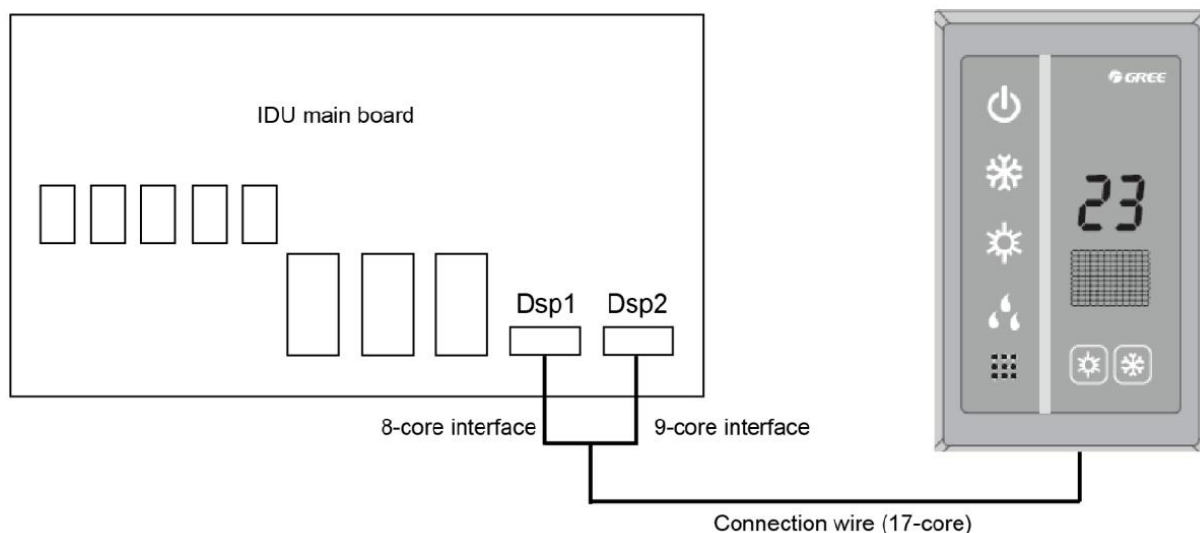

NOTES:

- a. The wired controller and remote receiving LED panel can be used at the same time.
- b. Note to select a remote controller when a remote receiving LED panel is used.

9 ELECTRICAL CONNECTION

9.1 External Connection Interfaces

External connection interfaces	Power supply	Quantity	4
		Label	L1 L2 L3 PE
	Indoor/outdoor unit communication	Quantity	2
		Label	D1 D2
	Centralized control	Quantity	2
		Label	G1 G2

9.2 External Connection

Every unit must be configured with a circuit breaker to implement short circuit and abnormal overload protection. Besides, the indoor unit and outdoor unit should be respectively configured with a general circuit breaker, which is used to uniformly connect to or cut off the general power supply for the indoor unit or outdoor unit.

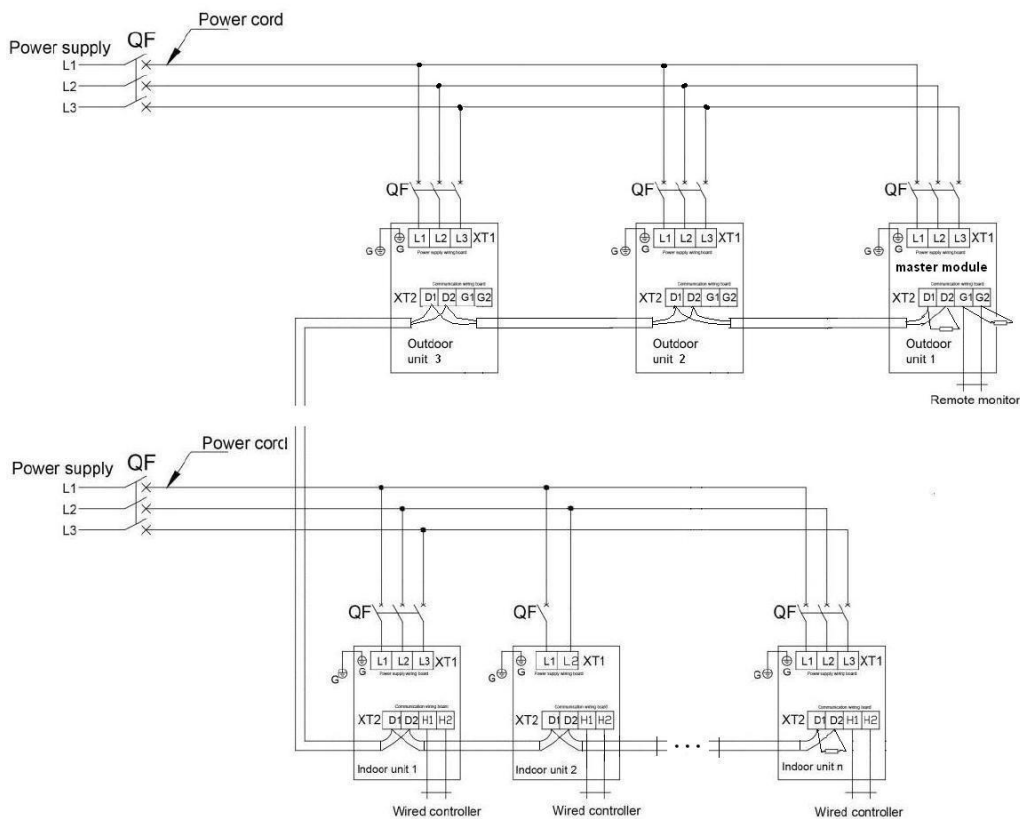

NOTES:

- The maximum number N of connected outdoor units and the maximum number n of connected indoor units depend on the outdoor unit combination form.
- A copper conductor must be used as a power cable. It must comply with the relevant national lead standard and meet the current-carrying capacity requirement of the unit.

10 CALCULATION METHOD OF REFRIGERANT ADDED FOR ENGINEERING PIPING

Added refrigerant quantity R = Added refrigerant quantity A for liquid piping + \sum Added refrigerant quantity B for each module

(1) Pipeline charging amount

Added refrigerant quantity A for liquid piping = \sum Liquid pipe length \times Added refrigerant quantity for each meter (inch) of liquid pipe

	Diameter of liquid pipe mm(inch)							
	28.6(1-1/8)	25.4(1)	22.2(7/8)	19.05(3/4)	15.9(5/8)	12.7(1/2)	9.52(3/8)	6.35(1/4)
kg/m	0.680	0.520	0.350	0.250	0.170	0.110	0.054	0.022
OZ/inch	0.61	0.47	0.31	0.22	0.15	0.10	0.05	0.02

(2) \sum Refrigerant charging amount B of every module

Refrigerant charging amount B of every module kg(lb)		Rated Capacity(1000Btu/h)	
IDU/ODU rated capacity collocation ratio C	Quantity of included IDUs(N)	72	96
50% \leq C \leq 90%	N<4	0	0
	N \geq 4	0.5(1.1)	1(2.2)
90%<C \leq 105%	N<4	0	0.5(1.1)
	8>N \geq 4	0.5(1.1)	1.5(3.3)
	N \geq 8	2(4.4)	3(6.6)
105%<C \leq 135%	N<4	0.5(1.1)	1(2.2)
	8>N \geq 4	2.5(5.5)	3.5(7.7)
	N \geq 8	4(8.8)	5(11.0)

For example:

The OUD is GMV-V192WM/A-F(U) including GMV-V96W/A-F(U) and GMV-V96W/A-F(U). The IDUs are made up of 11sets of GMV-ND18PHS/A-T(U).

IDU/ODU rated capacity collocation ratio C= $18 \times 11 / 192 = 103\%$.The quantity of included IDUs is more than 4 sets. Please refer to the above table.

Refrigerant charging amount B for GMV-V96W/A-F(U) module is 3kg(6.6lbs).

Refrigerant charging amount B for GMV-V96W/A-F(U) module is 3kg(6.6 lbs).

Suppose the Pipeline charging amount A=25kg (55.1 lbs)

Total refrigerant charging amount R= $25+3+3=31.5$ kg (55.1+6.6+6.6=68.3 lbs).

After confirming that there is no leakage from the system, charge additional R410A with specified amount to the unit through the filling opening of the liquid pipe valve of the outdoor unit when the compressor is not in operation. If required additional refrigerant cannot be quickly filled for increase of pressure in the pipe, set the unit at cooling startup and then fill the refrigerant from gas valve of outdoor unit. If ambient temperature is low, the unit can't be set to cooling mode but heating mode.

11 OPTIONAL COMPONENTS

The Ultra Heat GMV series VRF units provide the following options:

		Model	Remarks
Manifold	Outdoor unit	ML01R	For the model selection method, see the part of pipeline selection
	Indoor unit	FQ01A/A, FQ01B/A, FQ02/A, FQ03/A, FQ04/A	
Remote receiving LED panel		JS05	Applicable to the duct-type indoor unit
Remote controller for debugging		YV1L1	With the debugging function, used to set functions of the indoor unit
Classic wired controller		Wired controller XK46	Applicable to the air Cassette, Floor Ceiling, Wall-Mounted indoor unit (duct-type indoor unit standard)
Wired controller for hotel		Wired controller XK79	With the access control function
Color screen wired controller		Wired controller XK55	
Debugging Software		VRF Debugging Software.exe	Applicable to Ultra Heat GMV unit
Remote monitoring system	Software	VRF Monitoring System.exe	Applicable to Ultra Heat GMV unit
	Gateway	FE22-41/BEF(MCB)	
	Optoelectronic isolated repeater	RS485-W	

Note: if you need the above optional components, please consult your local sales company.

Gree Electric Appliances, Inc. of Zhuhai, founded in 1991, is the world's largest air conditioner enterprise integrating R&D, manufacturing, marketing and services. Technology Innovation and quality are always our priority. With efforts of thousands of Gree's engineers, we own more than 3500 patents for our products. Nowadays, we have 7 production bases in Zhuhai, Chongqing, Hefei and Zhengzhou (China), as well as Brazil, Pakistan and Vietnam, with annual production capacity of 30 million sets of residential air conditioners and 4 million sets of commercial air conditioners.

With the installation of Gree commercial air conditioners in important projects at home and abroad like Media Village for 2008 Beijing Olympic Games, Stadiums for 2010 World Cup in South Africa, as well as India Telecom base station, Gree commercial air conditioner are ready to develop steadily to every corner in the world, to present a more comfortable and harmonious working environment and family atmosphere.



GREE MAKING BETTER CONDITIONERS GREE MAKING BETTER CONDITIONERS GREE MAKING BETTER CONDITIONERS GREE MAKIN BETTER CONDITIONERS GREE M



Add: West Jinji Rd, Qianshan Zhuhai,Guangdong, China519070

Tel: (+86-756)8614883 Fax: (+86-756)8614998

Http://www.gree.com Email: gree@gree.com.cn

For continuous improvement in the products, Gree reserves the right to modify the product specification and appearance in this manual without notice and without incurring and obligations.